

SAND 2005-0342-N
Unlimited Release
Revised March 2007

Supersedes SAND2005-0342
Dated February 2005

ELECTRONIC VERSION 1.6
Dated March 22, 2007

Photovoltaic Power Systems
And the
2005 National Electrical Code:
Suggested Practices

John Wiles
Southwest Technology Development Institute
New Mexico State University
PO Box 30001, MSC 3 SOLAR
Corner of Research Drive and Sam Steel Way
Las Cruces, NM 88003

ABSTRACT

This suggested practices manual examines the requirements of the *2005 National Electrical Code (NEC)* as they apply to photovoltaic (PV) power systems. The design requirements for the balance-of-systems components in a PV system are addressed, including conductor selection and sizing, overcurrent protection device rating and location, and disconnect rating and location. PV array, battery, charge controller, and inverter sizing and selection are not covered, as these items are the responsibility of the system designer, and they in turn determine the items in this manual. Stand-alone, hybrid, and utility-interactive PV systems are all covered. References are made to applicable sections of the *NEC*.

ACKNOWLEDGMENTS

Numerous people throughout the photovoltaic industry and the electrical inspector community reviewed the earlier editions of this manual and provided comments that are incorporated in this edition. The author sends heartfelt thanks to all who have supported the efforts to improve and expand the document. With inputs from all involved, each succeeding edition is progressively more detailed and complete. Ward Bower at Sandia National Laboratories deserves special thanks for his dedicated and continuing support and review of this document. Ronald Donaghe, Southwest Technology Development Institute, performed document editing and layout.

TECHNICAL COMMENTS TO:

John C. Wiles
Southwest Technology Development Institute
New Mexico State University
P.O. Box 30001/MSC 3 SOLAR
Corner of Research Drive and Sam Steel Way
Las Cruces, New Mexico 88003-0001

Phone: 505-646-6105 FAX 505-646-3841 e-mail: jwiles@nmsu.edu

Copies may be downloaded from the PV and Codes links on the SWTDI/NMSU web site at <http://www.nmsu.edu/~tdi>

PURPOSE

This document is intended to contribute to the widespread installation of safe, reliable PV systems that meet the requirements of the *National Electrical Code*.

DISCLAIMER

This guide provides information on how the *2005 National Electrical Code (NEC)* applies to photovoltaic systems. The guide is not intended to supplant or replace the *NEC*; it paraphrases the *NEC* where it pertains to photovoltaic systems and should be used with the full text of the *NEC*. Users of this guide should be thoroughly familiar with the *NEC* and know the engineering principles and hazards associated with electrical and photovoltaic power systems. The information in this guide is the best available at the time of publication and is believed to be technically accurate. Application of this information and results obtained are the responsibility of the user.

In most locations, all electrical wiring including photovoltaic power systems must be accomplished by, or under the supervision of, a licensed electrician and then inspected by a designated local authority. Some municipalities have additional codes that supplement or replace the *NEC*. The local inspector has the final say on what is acceptable. In some areas, compliance with the *NEC* is not required.

NATIONAL FIRE PROTECTION ASSOCIATION (NFPA) STATEMENT

The *National Electrical Code* including the *2005 National Electrical Code* is published and updated every three years by the National Fire Protection Association (NFPA), Batterymarch Park, Quincy, Massachusetts 02269. The *National Electrical Code* and the term *NEC* are registered trademarks of the National Fire Protection Association and may not be used without their permission. Copies of the current edition of the *National Electrical Code* and the *National Electrical Code Handbook* are available from the NFPA at the above address, most electrical supply distributors, and many bookstores.

Table of contents

SUGGESTED PRACTICES 1

Introduction 1

Methods of Achieving Objectives 3

Scope and Purpose of the *National Electrical Code*..... 4

This Guide 5

Longevity, Materials, and Safety..... 5

Testing and Approval..... 6

Photovoltaic Modules 7

 Module Marking..... 7

 WIRING 9

 Module Interconnections 9

 Tracking Modules 10

 Terminals 11

 Transition Wiring..... 13

 Module Connectors 15

 Module Connection Access 15

 Splices..... 15

Conductor Color Codes..... 18

PV Array Ground-Fault Protection..... 18

PV Array Installation and service..... 19

Grounding..... 20

 Definitions 20

 Grounding—System..... 20

 Size of DC Grounding Electrode Conductor..... 21

 Point of Connection 21

 Unusual Grounding Situations 23

 Charge Controllers—System Grounding..... 24

 Ungrounded Systems 25

 Equipment Grounding 25

 Inverter AC Outputs 26

 PV Inverters Create Separately Derived Systems..... 26

 AC Grounding 27

 DC Grounding 27

 Backup Generators 28

 Suggested AC Grounding 29

 Grounding Electrode 29

Conductor Ampacity	31
Stand-Alone Systems—Inverters	33
Overcurrent Protection	33
Ampere Rating	34
Branch Circuits.....	37
Amperes Interrupting Rating (AIR)—Short-Circuit Conditions	38
Fusing of PV Source Circuits	39
Current-Limiting Fuses—Stand-Alone Systems	40
Current-Limiting Fuses—Utility-interactive Systems	41
Fuse Servicing.....	41
Disconnecting Means	41
Photovoltaic Array Disconnects.....	42
PV DISCONNECT LOCATION	42
Equipment Disconnects	43
Battery Disconnect	44
Charge Controller Disconnects	46
UNGrounded Systems	47
Multiple Power Sources.....	47
Panelboards, Enclosures, and Boxes.....	47
Batteries.....	48
Hydrogen Gas	48
Battery Rooms and Containers	49
Acid or Caustic Electrolyte.....	49
Electric Shock Potential.....	50
Battery and other large Cables	50
Generators	50
Charge Controllers	52
Inverters.....	53
Stand-Alone Distribution Systems.....	53
Interior DC Wiring and Receptacles	56
Smoke Detectors	58
Ground-Fault Circuit Interrupters	58
Interior Switches	58
Multiwire Branch Circuits	59
AC PV Modules.....	61
System Labels and Warnings	62
Photovoltaic Power Source.....	62
Multiple Power Systems.....	62
INTERACTIVE SYSTEM POINT OF INTERCONNECTION.....	62

Switch or Circuit Breaker	62
General.....	63
Inspections.....	63
Insurance	63
APPENDIX A: Sources of Equipment Meeting the Requirements of The <i>National Electrical Code</i>	A-1
CONDUCTORS.....	A-1
DC-RATED FUSES.....	A-2
ENCLOSURES AND JUNCTION BOXES	A-4
HYDROCAPS	A-4
APPENDIX B: PV Module Operating Characteristics Drive <i>NEC</i> Requirements	B-1
Introduction.....	B-1
UNSPECIFIED DETAILS	B-2
<i>NEC</i> REQUIREMENTS BASED ON MODULE PERFORMANCE.....	B-2
Voltage.....	B-2
Current	B-3
additional <i>NEC</i> Requirements.....	B-3
summary	B-4
APPENDIX C: Utility-Interactive Systems	C-1
Inverters	C-1
PV Source-Circuit Conductors.....	C-3
Overcurrent Devices.....	C-3
Backfed Circuit Breakers, The <i>National Electrical Code</i> and UL Standards	C-3
Utility-Interactive PV Systems.....	C-3
Summary	C-5
Disconnects.....	C-5
Blocking Diodes.....	C-5
Surge Suppression.....	C-6
APPENDIX D: Cable and Device Ratings at High Voltages.....	D-1
Equipment Ratings	D-1
<i>NEC</i> VOLTAGE Limitation.....	D-4
Voltage Remedies	D-4
APPENDIX E: Example Systems.....	E-1
Cable Sizing and Overcurrent Protection	E-1
Examples.....	E-3
APPENDIX F: DC Currents on Single-Phase Stand-alone Inverters	F-1
APPENDIX G: Grounding PV Modules.....	G-1
APPENDIX H: PV Ground Fault Protection Devices and The <i>National Electrical Code</i> , Section 690.5	H-1

APPENDIX I: Selecting Overcurrent Devices and Conductors in PV Systems I-1

APPENDIX J: Fusing of DC PV Module Circuits in Utility-Interactive PV Systems..... J-1

APPENDIX K: Flexible, Fine-Stranded Cables: Incompatibilities
with Set-Screw Mechanical Terminals and Lugs K-1

 Solutions K-3

APPENDIX L: Ungrounded PV Systems L-1

APPENDIX M: Service Entrance Conductor Taps for Utility-Interactive
Inverter Systems M-1

INDEX 1

Distribution List..... 1

List of Figures

Figure 1:	Warning Label	6
Figure 2.	Label on Typical PV Module	8
Figure 3.	Strain Reliefs	9
Figure 4.	Terminal Crimping Tools	12
Figure 5.	Crimp Terminals/Lugs	12
Figure 6	Mechanical Terminals.....	13
Figure 7.	PV Combiner with Circuit Breakers	14
Figure 8.	Common Splicing Devices	16
Figure 9.	Module Interconnect Methods.....	17
Figure 10.	Typical System: Possible Grounding Conductor Locations.....	22
Figure 11.	Utility-Interactive Inverter with Internal DC Bonding Point, GFPD, and Connection Point for Grounding Electrode Conductor	23
Figure 12.	External Ground-Fault Protection Device	28
Figure 13.	Example Grounding Electrode System.....	30
Figure 14.	Typical Array Conductor Overcurrent Protection (with Optional Subarray Disconnects)	35
Figure 15.	Listed Branch-Circuit Rated Breakers	36
Figure 16.	Recognized (left) and listed (right) DC Circuit Breakers	36
Figure 17.	Listed Supplementary (left) and Branch Circuit(right) Fuses	37
Figure 18.	Unacceptable Automotive Fuses (left) and Unacceptable AC Fuses (right).....	38
Figure 19.	Small System Disconnects.....	45
Figure 20.	Separate Battery Disconnects	45
Figure 21.	Charge Controller Disconnects	46
Figure 22.	Disconnects for Remotely Located Power Sources	51
Figure 23.	Typical Charge Controller	52
Figure 24.	12-Volt DC Load Center.....	55
Figure 25.	12-Volt DC Combining Box and Load Center.....	56
Figure 26.	NEMA Plug Configurations	57
Figure 27.	Diagram of a Multiwire Branch Circuit.....	61
Figure C-1.	400 Amp Panel – Commercial PV Installation	C-2
Figure D-1.	Typical Bipolar System with Fault	D-3
Figure E-1.	Direct Connected System	E-4
Figure E-2.	Direct-Connected PV System with Current Booster.....	E-7
Figure E-3.	Stand-Alone Lighting System	E-9
Figure E-4.	Remote Cabin DC-Only System	E-11
Figure E-5.	Small Residential Stand-Alone System	E-13

Figure E-6. Medium Sized Residential Hybrid System.....	E-16
Figure E-7. Roof-Top Utility-interactive System	E-19
Figure E-8. Center-Tapped PV System	E-22
Figure E-9. Utility-Interactive Three-Inverter System	E-25
Figure F-1. Inverter Current Waveform (dc side).....	F-1
Figure G-1. ILSCO GBL4-DBT Lug	G-2
Figure G-2. Improper Module Grounding	G-4
Figure H-1. Ground-Fault Current Paths.....	H-1
Figure K-1. Examples of Mechanical Terminals.....	K-1
Figure K-2. Destroyed Mechanical Terminal From PV System	K-2
Figure K-3 Typical Compression Lug.....	K-3

APPLICABLE ARTICLES

In the

2005 NATIONAL ELECTRICAL CODE

Although most portions of the *National Electrical Code* apply to all electrical power systems, including photovoltaic power systems, those listed below are of particular significance.

Article	Contents
90	Introduction
100	Definitions
110	Requirements for Electrical Installations
200	Use and Identification of Grounded Conductors
210	Branch Circuits
240	Overcurrent Protection
250	Grounding and Bonding
300	Wiring Methods
310	Conductors for General Wiring
334	Nonmetallic-Sheathed Cable: Types NM, NMC, and NMS
336	Power and Control Tray Cable: Type TC
338	Service-Entrance Cable: Types SE and USE
340	Underground Feeder and Branch-Circuit Cable: Type UF
352	Rigid Nonmetallic Conduit: Type RNC
356	Liquidtight Flexible Nonmetallic Conduit: Type LFNC
366	Auxiliary Gutters
400	Flexible Cords and Cables
408	Switchboards and Panelboards
445	Generators
480	Storage Batteries
490	Equipment, Over 600 Volts, Nominal
690	Solar Photovoltaic Systems
705	Interconnected Electric Power Production Sources
720	Circuits and Equipment Operating at Less Than 50 Volts
Ch 9, Table 8	Conductor Properties
Annex C	Conduit and Tubing Fill Tables for Conductors and Fixture Wires of the Same Size

SUGGESTED PRACTICES

OBJECTIVE

- SAFE, RELIABLE, DURABLE PHOTOVOLTAIC POWER SYSTEMS
- KNOWLEDGEABLE MANUFACTURERS, DESIGNERS, DEALERS, INSTALLERS, CONSUMERS, AND INSPECTORS

METHOD

- WIDESPREAD DISSEMINATION OF THESE SUGGESTED PRACTICES AND KNOWLEDGE OF THE *NEC*
- TECHNICAL INTERCHANGE AMONG INTERESTED PARTIES

INTRODUCTION

The National Fire Protection Association has acted as sponsor of the *National Electrical Code (NEC)* since 1911. The original Code document was developed in 1897. With few exceptions, electrical power systems installed in the United States in the 20th and 21st centuries have had to comply with the *NEC*. This compliance requirement applies to most permanent installations of photovoltaic (PV) power systems. In 1984, Article 690 Solar Photovoltaic Systems, which addresses safety requirements for the installation of PV systems, was added to the Code. This article has been updated and expanded in each edition of the *NEC* since 1984.

Many of the PV systems in use and being installed today may not be in compliance with the *NEC* and other local codes. There are several contributing factors to this situation:

Factors that have reduced local and <i>NEC</i> compliance
--

- The PV industry with increased financial incentives is attracting installers who are not fully aware of the dangers associated with low-voltage and high-voltage, direct-current (dc) and alternating-current (ac) electrical power systems.
- Electricians and electrical inspectors have not had significant experience with direct-current portions of the Code or PV power systems.
- The electrical equipment industries do not advertise or widely distribute equipment suitable for dc use that meets *NEC* requirements.

- Popular publications present information to the public that implies that PV systems are easily installed, modified, and maintained by untrained personnel.
- Photovoltaic equipment manufactured outside the US, while having attractive cost and performance benefits, has not been tested and listed by approved testing laboratories like Underwriters Laboratories (UL), Canadian Standards Association (CSA) or ETL SEMKO (ETL).
- Photovoltaic installers and dealers in many cases have not had significant training or experience installing ac residential and/or commercial power systems.

Some PV installers in the United States are licensed electricians or use licensed electrical contractors and are familiar with all sections of the *NEC*. These installer/contractors are trained to install safe and more reliable PV systems that meet the *NEC* and minimize the hazards associated with electrical power systems. On the other hand, some PV installations have numerous defects that typically stem from unfamiliarity with electrical power system codes or unfamiliarity with dc currents and power systems. These installations often do not meet the requirements of the *NEC*. Some of the more prominent problems are listed below.

**Observed PV
installation
problems**

- Improper ampacity of conductors
- Improper types of conductors
- Improper or unsafe wiring methods
- Lack of or improper overcurrent protection on conductors
- Inadequate number and placement of disconnects
- Improper application of listed equipment
- No, or underrated, short-circuit or overcurrent protection on battery circuits
- Use of non-listed components when listed components are available
- Improper system grounding
- Lack of, or improper, equipment grounding
- Use of underrated hardware or components
- Use of ac components (fuses and switches) in dc applications

The *NEC* generally applies to any PV power system, regardless of size or location. A single, small PV module may not present a significant hazard, and a small system in a remote location may present few safety hazards because people are seldom in the area. On the other hand, two or three modules connected to a battery can be lethal if not installed and operated properly. A single deep-cycle storage battery (6 volts, 220 amp-hours) can discharge about 8,000 amps into a terminal-to-terminal short-circuit. Systems operate with voltages ranging from 12 volts to 600 volts or higher and can present shock hazards. Short circuits, even on lower voltage systems,

present fire and equipment hazards. Storage batteries can be dangerous; hydrogen gas and acid residue from lead-acid batteries, although not *NEC*-specific, need to be dealt with safely.

The problems are compounded because, unlike with ac systems, there are few listed components that can be easily “plugged” together to result in a safe PV system. The available PV hardware does not have mating inputs or outputs, and the knowledge and understanding of “what works with what” is not second nature to the installer. The dc PV “cookbook” of knowledge does not yet exist.

METHODS OF ACHIEVING OBJECTIVES

To meet the objective of safe, reliable, durable photovoltaic power systems, the following suggestions are offered:

Safe...

Reliable...

Durable...

- Dealer-installers of PV systems should become familiar with the *NEC* methods of and requirements for wiring residential and commercial ac power systems.
- All PV installations should be permitted and inspected, where required, by the local inspection authority in the same manner as other equivalent electrical systems.
- Photovoltaic equipment manufacturers should build equipment to meet UL or other recognized standards and have equipment tested and listed.
- Listed subcomponents should be used in field-assembled equipment where formal testing and listing is not possible.
- Electrical equipment manufacturers should produce, distribute, and advertise, listed, reasonably priced, dc-rated components.
- Electrical inspectors should become familiar with dc and PV systems.
- The PV industry should educate the public, modify advertising, and encourage all installers to comply with the *NEC*.
- Existing PV installations should be upgraded to comply with the *NEC* and other minimum safety standards.

SCOPE AND PURPOSE OF THE *NATIONAL ELECTRICAL CODE*

Some local inspection authorities use regional electrical codes, but most jurisdictions use the *National Electrical Code*—sometimes with slight modifications. The *NEC* states that adherence to the recommendations made will reduce the hazards associated with electrical installations. The *NEC* also says these recommendations may not lead to improvements in efficiency, convenience, or adequacy for good service or future expansion of electrical use [90.1]. (Numbers in brackets refer to sections in the 2005 *NEC*.)

The *National Electrical Code* addresses nearly all PV power installations, even those with voltages of less than 50 volts [720]. It covers stand-alone and utility-interactive systems. It covers billboards, other remote applications, floating buildings, and recreational vehicles (RV) [90.2(A), 690]. The Code deals with any PV system that has external wiring or electrical components that must be assembled and connected in the field and that is accessible to the untrained and unqualified person.

There are some exceptions. The *National Electrical Code* does not cover PV installations in automobiles, railway cars, boats, or on utility company properties used for power generation [90.2(B)]. It also does not cover micro-power systems used in watches, calculators, or self-contained electronic equipment that have no external electrical wiring or contacts.

Article 690, Solar Photovoltaic Systems of the *NEC* specifically deals with PV systems, but many other sections of the *NEC* contain requirements for any electrical system including PV systems [90.2, 720]. When there is a conflict between Article 690 of the *NEC* and any other article, Article 690 takes precedence [690.3].

The *NEC* suggests (in some cases requires), and most inspection officials require, that equipment identified, listed, labeled, or tested by an approved testing laboratory be used when available [90.7, 100, 110.3]. The three most commonly encountered national testing organizations commonly acceptable to most jurisdictions are the *Underwriters Laboratories (UL)*, *Canadian Standards Association (CSA)* and *ETL Testing Laboratories, Inc. (ETL)*. *Underwriters Laboratories* and *UL* are registered trademarks of Underwriters Laboratories Inc. *ETL* is a registered trademark of ETL Testing Laboratories, Inc. *CSA* is a registered trademark of the Canadian Standards Association.

Most building and electrical inspectors expect to see a listing mark (UL, CSA, ETL) on electrical products used in electrical systems in the United States. This listing requirement presents a problem for some in the PV industry, because low production rates may not justify the costs of testing and listing by UL or other laboratory. Some manufacturers claim their product specifications exceed those required by the testing organizations, but inspectors readily admit to not having the expertise, time, or funding to validate these unsubstantiated claims.

THIS GUIDE

The recommended installation practices contained in this guide progress from the photovoltaic modules to the electrical outlets (in a stand-alone system) or to the utility interconnection (in a utility-interactive system). For each component, *NEC* requirements are addressed, with the appropriate Code sections referenced in brackets. A sentence, phrase, or paragraph followed by a *NEC* reference refers to a requirement established by the *NEC*. The words “**will**,” “**shall**,” or “**must**” also refer to *NEC* requirements. Suggestions based on field experience with PV systems are worded as such and will use the word “should.” The recommendations apply to the use of listed products. The word “Code” in this document refers to the *2005 NEC*. In some places references will also be made to Article 690 from the *2002 NEC* that have been significantly changed in the *2005 NEC*.

In recent times, monetary incentives have resulted in large numbers of utility-interactive PV systems being installed. While most of these systems are purely grid-tied, many have batteries included to provide energy during blackouts, and some even include generators. With these added features, there are many similarities between the code requirements for utility-interactive systems and stand-alone systems. In this suggested practices manual, the code requirements are addressed at the component level and at the interconnection level between components. Where unique requirements apply, they are addressed as they relate to a particular system. Appendices provide additional details.

Appendix A provides a limited list of sources for dc-rated and identified, or listed, products, and references to the products are made as they are discussed.

Other appendices address details and issues associated with implementing the *NEC* in PV installations. Examples are included.

LONGEVITY, MATERIALS, AND SAFETY

Although PV modules are warranted for power output for periods from 10-25 years, they can be expected to deliver dangerous amounts of energy (voltage and current) for periods of 40 to 50 years and longer. The warning on the back of PV modules is worth reading and heeding. See Figure 1. Each and every designer and installer of PV systems should strive to make the installation as durable and as safe as possible. The *NEC* provides only minimal safety requirements and general guidance on materials, and does not fully address the durability issues associated with installing electrical systems that must last for 50 years or longer. The PV module environment is harsh with temperatures ranging from -50°C to $+85^{\circ}\text{C}$, very dry to monsoon moisture conditions, long-term ultraviolet exposure, and high mechanical loading from winds and ice. The use of materials tested and listed for outdoor exposure in the outdoor sections of the system is an absolute safe-practices requirement. Exceeding Code minimums for materials and installation practices is encouraged to ensure PV array and system longevity.

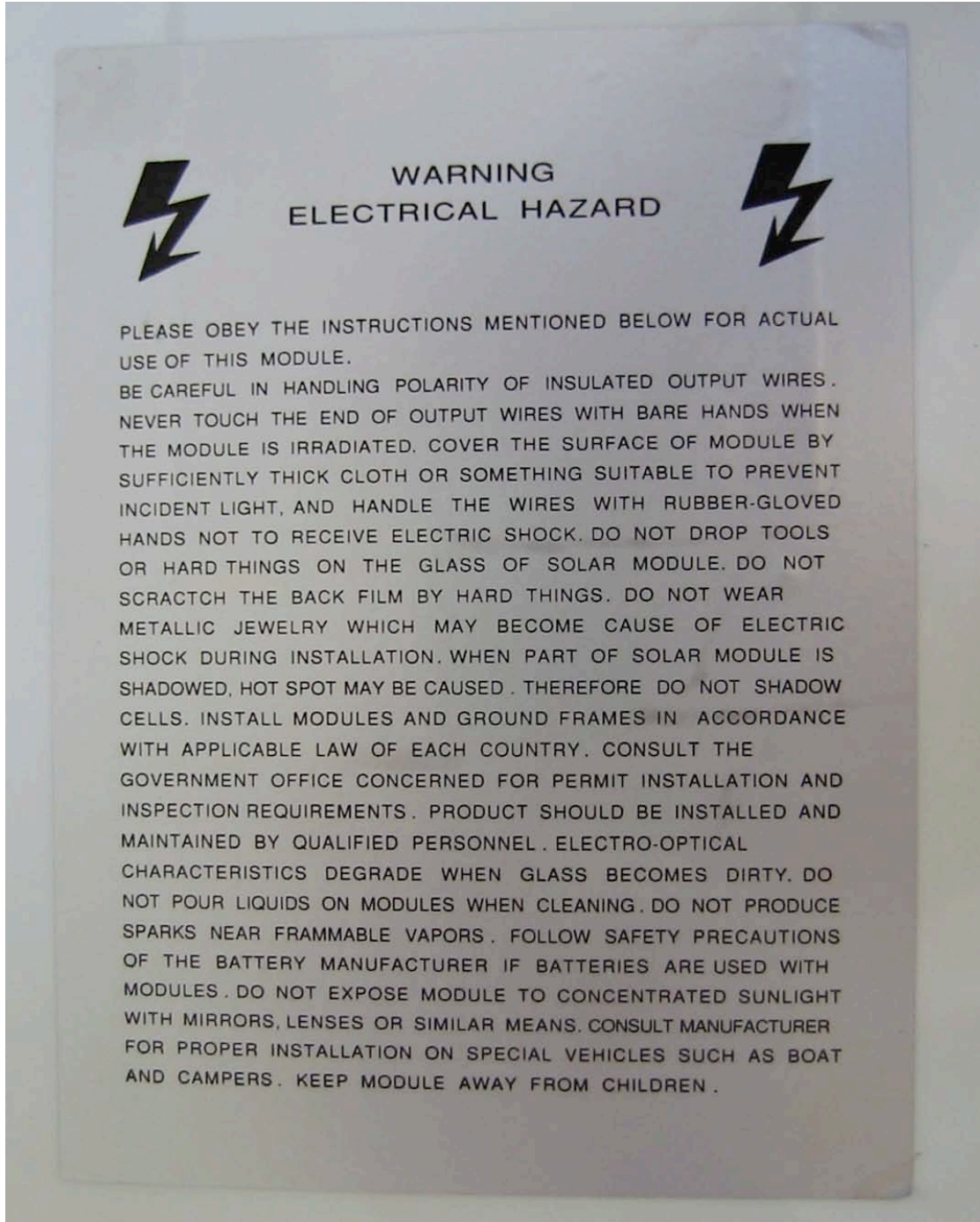

Figure 1. Warning Label

TESTING AND APPROVAL

The *NEC* suggests (and in some cases requires), and many inspectors require that listed devices be used throughout a PV system. A *listed* device by UL or other approved testing laboratory is tested against an appropriate UL standard. A *recognized* device is tested by UL or other

approved testing laboratory to standards established by the device manufacturer. In most cases, the requirements established by the manufacturer are less rigorous than those established by UL. Few inspectors will accept recognized devices, particularly where they are required for overcurrent protection. *Recognized* devices are generally intended for use within a factory assembly or equipment that will be further *listed* in its entirety.

PHOTOVOLTAIC MODULES

Numerous PV module manufacturers offer listed modules. In some cases (building integrated or architectural structures), unlisted PV modules have been installed, but these installations should have been approved by the local authority having jurisdiction (electrical inspector).

MODULE MARKING

Certain electrical information **must** appear on each module. The information on the factory-installed label shall include the following items [690.51]:

**Information
Supplied by
Manufacturer**

- Polarity of output terminals or leads
- Maximum series fuse for module protection
- Rated open-circuit voltage
- Rated operating voltage
- Rated operating current
- Rated short-circuit current
- Rated maximum power
- Maximum permissible system voltage [690.51]

Figure 2 shows a typical label that appears on the back of a module.

Although not required by the *NEC*, the temperature rating of the module terminals and conductors are given to determine the temperature rating of the insulation of the conductors and how the ampacity of those conductors **must** be derated for temperature [110.14(C)]. While module terminals are usually rated for 90°C, most other terminals throughout the PV system will have terminals rated only for 60°C or 75°C. These terminal temperatures may significantly affect conductor ampacity.

Note: Other critical information, such as mechanical installation instructions, grounding requirements, tolerances of indicated values of I_{sc} , V_{oc} and P_{max} , and statements on artificially concentrated sunlight are contained in the installation and assembly instructions for the module.

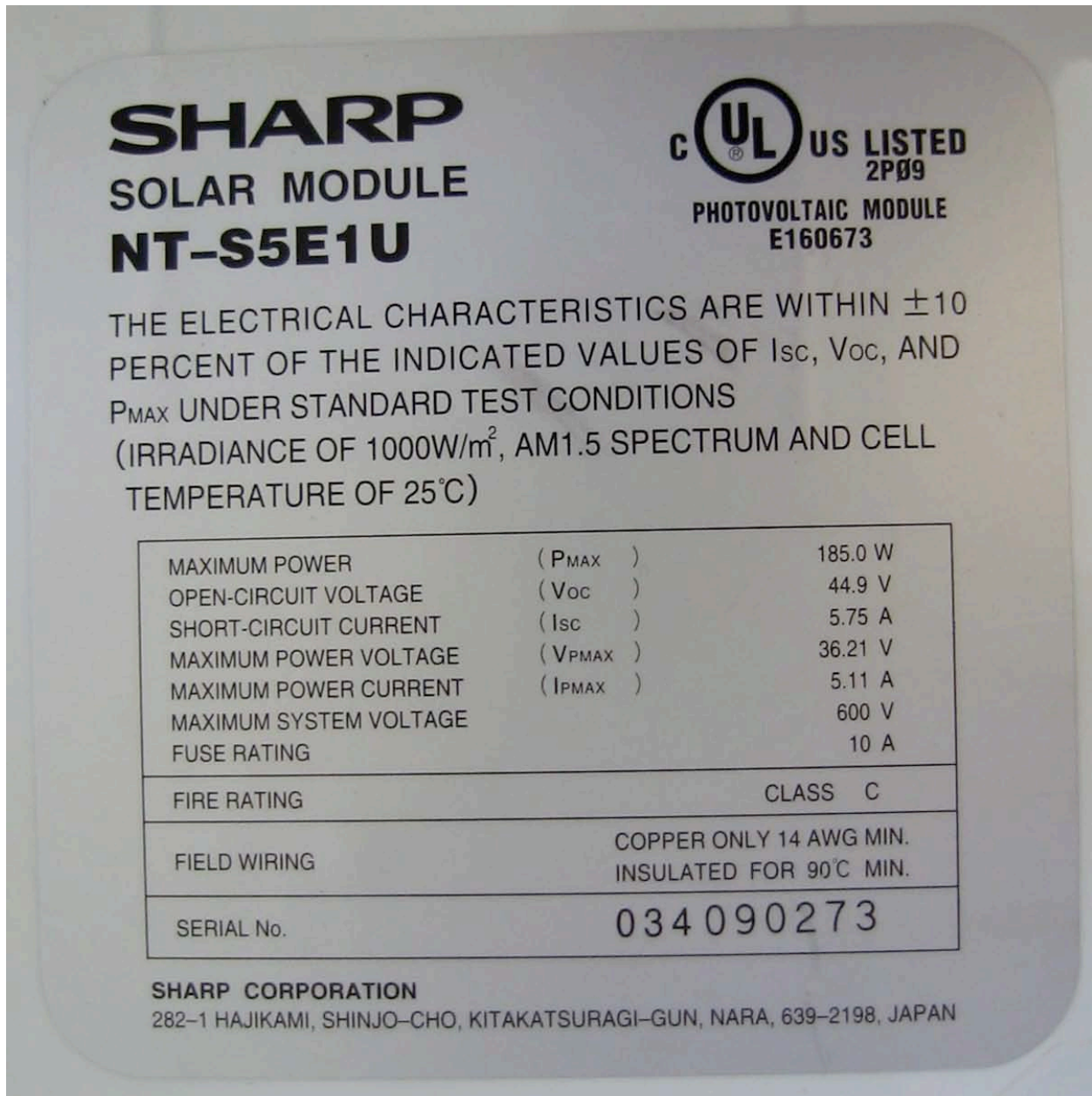

Figure 2. Label on Typical PV Module

Methods of connecting wiring to the modules vary from manufacturer to manufacturer. A number of manufacturers make modules with 48-inch lengths of interconnection cables permanently connected to the modules. There are no junction boxes for connection of conduit. The *NEC* does not require conduit, but local jurisdictions, particularly in commercial installations, may require conduit. The Code requires that strain relief be provided for connecting wires. If the module has a closed weatherproof junction box, strain relief and moisture-tight clamps should be used in any knockouts provided for field wiring. Where the weather-resistant gaskets are a part of the junction box, the manufacturer's instructions **must** be followed to ensure proper strain relief and weatherproofing [110.3(B), *UL Standard 1703*]. Figure 2 shows various types of strain relief clamps. The one on

the left is a basic cable clamp for interior use with nonmetallic-sheathed cable (Romex[®]) that cannot be used for module wiring. The clamps in the center (Heyco) and on the right (T&B) are watertight and can be used with either single or multiconductor cable—depending on the insert.



Figure 3. Strain Reliefs

WIRING

MODULE INTERCONNECTIONS

Copper conductors are recommended for almost all photovoltaic system wiring [110.5]. Copper conductors have lower voltage drops and better resistance to corrosion than other types of comparably sized conductor materials. Aluminum or copper-clad aluminum wires can be used in certain applications, but the use of such cables is not recommended—particularly in dwellings. All wire sizes presented in this guide refer to copper conductors.

The *NEC* requires 12 AWG (American Wire Gage) or larger conductors to be used with systems under 50 volts [720.4]. Article 690 ampacity calculations yielding a smaller conductor size might override Article 720 considerations, but some inspectors are using the Article 720 requirement for dc circuits [690.3]. The Code has little information for conductor sizes smaller than 14 AWG, but Section 690.31(D) provides some guidance. Many listed PV modules are furnished with attached 14 AWG conductors.

Single-conductor, Type UF (Underground Feeder—Identified (marked) as Sunlight Resistant), Type SE (Service Entrance), or Type USE/USE-2 (Underground Service Entrance) cables are permitted for module interconnect wiring [690.31(B)]. Type UF cable **must** be marked “Sunlight Resistant” when exposed outdoors as it does not have the inherent sunlight resistance found in SE and USE conductors [UL Marking Guide for Wire and Cable]. Unfortunately, single-conductor, stranded, UF sunlight-resistant cable is not readily available and may have only a 60°C temperature rating. This 60°C-rated insulation is not suitable for long-term exposure to direct sunlight at temperatures likely to occur near PV modules. Such wire has shown signs of deterioration after four years of exposure. Temperatures exceeding 60°C normally occur in the vicinity of the modules; therefore, conductors with 60°C insulation cannot be used. Stranded wire is suggested to ease servicing of the modules after installation and for durability [690.34].

The widely available Underground Service Entrance Cable (USE-2) is suggested as the best cable to use for module interconnects. When manufactured to the UL Standards, it has a 90°C temperature rating and is sunlight resistant even though not commonly marked as such. The “-2” marking indicates a wet-rated 90°C insulation, the preferred rating. Additional markings indicating XLP or XLPE (cross-linked polyethylene) and RHW-2 (90°C insulation when wet) ensure that the highest quality cable is being used [Tables 310.13, 16, and 17]. An additional marking (not required) of “Sunlight Resistant” indicates that the cable has passed an extended UV exposure test over that normally required by USE-2. USE-2 is acceptable to most electrical inspectors. The RHH and RHW-2 designations frequently found on USE-2 cable allow its use in conduit inside buildings. USE or USE-2 cables, without the other markings, do not have the fire-retardant additives that SE and RHW/RHW-2 cables have and cannot be used inside buildings.

If a more flexible, two-conductor cable is needed, electrical tray cable (Type TC) is available but **must** be supported in a specific manner as outlined in the *NEC* [336 and 392]. TC is sunlight resistant and is generally marked as such. Although sometimes used (improperly) for module interconnections, SO, SOJ, and similar flexible, portable cables and cordage may not be sunlight resistant and are not approved for fixed (non-portable) installations [400.7, 8].

The temperature derated ampacity of conductors at any point **must** generally be at least 156% of the module (or array of parallel-connected modules) rated short-circuit current at that point [690.8(A), (B)]. See later sections of this manual for details on ampacity calculations.

TRACKING MODULES

Where there are moving parts of an array, such as a flat-plate tracker or concentrating modules, the *NEC* does allow the use of flexible cords and cables [400.7(A), 690.31(C)]. When these types of cables are used, they should be selected for extra-hard usage with full outdoor ratings (marked “WA” or “W” on the cable). They should not be used in conduit. Temperature derating information

is provided by Table 690.31C. A temperature correction factor in the range of 0.33 to 0.58 should be used for flexible cables used as module interconnects.

Trackers in PV systems operate at relatively slow angular rates and with limited motion. Normal stranded wire (exposed USE-2 or THWN-2 inside flexible conduit) has demonstrated good performance without deterioration due to flexing.

Another possibility is the use of extra flexible (400+ strands) building cable type USE-RHH-RHW or THW. This cable is available from the major wire distributors (Appendix A). However, it should be noted that few mechanical terminals (screw or setscrew types) are listed for use with other than the normal Class B or C stranded cables (7, 19 or 37 strands). Cable types, such as THW or RHW that are not sunlight resistant, should be installed in flexible liquidtight conduit.

TERMINALS

Module junction boxes have various types of terminals inside junction boxes or permanently-connected leads (with and without connectors). The instructions furnished with each module will state the acceptable size and type of wires for use with the terminals. Ampacity calculations will dictate the minimum conductor sizes allowed. Some modules may require the use of crimp-on terminals when stranded conductors are used. The use of a crimp-on (compression) terminal is usually required when fine stranded conductors are being used with mechanical terminals (setscrew or screw fasteners) unless the terminal is marked for use with fine stranded cables. Very few, if any, are marked for use with fine stranded conductors.

Light-duty crimping tools designed for crimping smaller wires used in electronic components usually do not provide sufficient force to make long-lasting crimps on connectors for PV installations even though they may be sized for 12-10 AWG. Insulated terminals crimped with these light-duty crimping tools frequently develop high-resistance connections in a short time and may even fail as the wire pulls out of the terminal. It is strongly suggested that only listed or device specific, heavy-duty industrial-type crimping tools be used for PV system wiring where crimp-on terminals are required. Figure 4 shows four styles of crimping tools. On the far left is a common handyman locking pliers that *should not* be used for electrical connections. On the left center is a stripper/crimper used for electronics work that will crimp only insulated terminals. These two types of crimping tools are frequently used to crimp terminals on PV systems; however, since they are not listed devices, their use is discouraged. The two crimping tools on the right are listed, heavy-duty industrial designs with ratcheting jaws and interchangeable dies that will provide the highest quality connections. They are usually available from electrical supply houses.

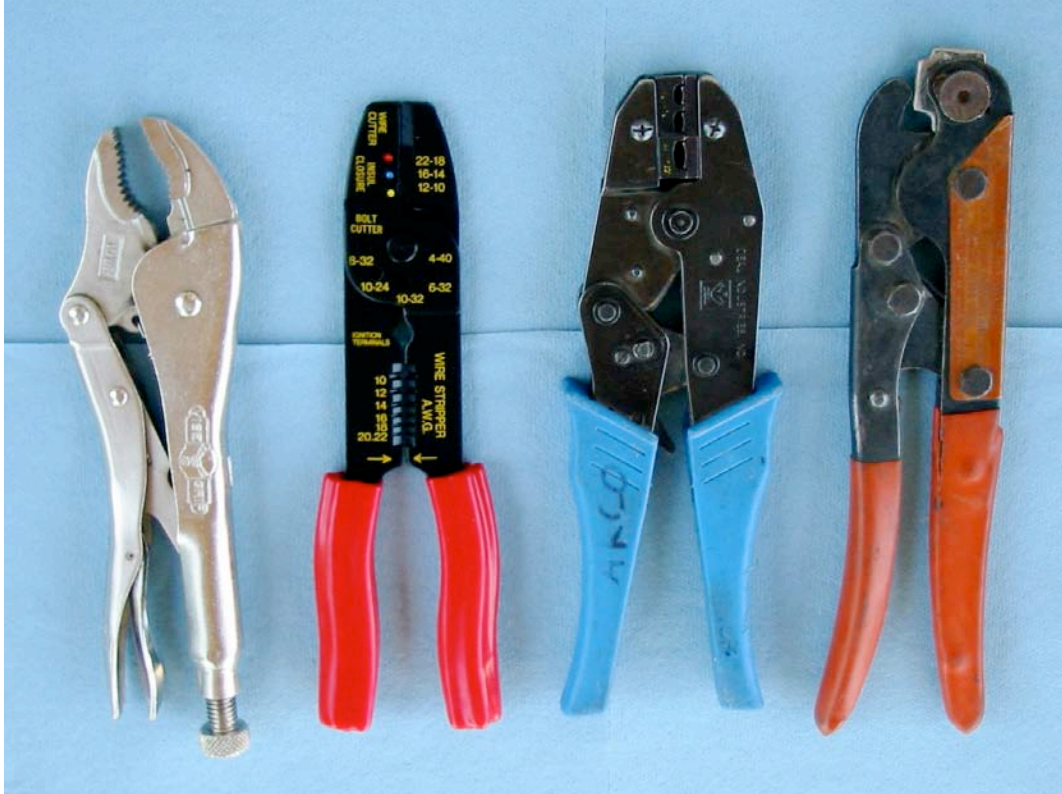

Figure 4. Terminal Crimping Tools-Two on Left Unlisted, Two on Right Listed



Figure 5. Crimp Terminals/Lugs-All Listed, but Not All Suitable for All Applications

Figure 5 shows some examples of insulated and uninsulated terminals. In general, uninsulated terminals are preferred (with insulation applied later if required), but the heavier, more reliable listed electrical terminals, not unlisted electronic or automotive grades, are required. Again, an electrical supply house rather than an electronic or automotive parts store is the place to find the required items. Terminals are listed only when installed using the instructions supplied with the terminals and when used with the related crimping tool (usually manufactured or specified by the manufacturer of the terminals). If the junction box provides mechanical pressure terminals, it is not necessary to use crimped terminals unless fine stranded conductors are used.

Figure 6 shows a few mechanical terminals. The screws and setscrews used in these devices usually indicate that they are not listed for use with fine stranded, flexible conductors, but are intended for use only with the normal 7 or 19 strand conductors. Any terminal block used **must** be listed as suitable for use with “field-installed wiring [110.3(B)].”



Figure 6. Listed Mechanical Terminals

TRANSITION WIRING

Because of the relatively higher cost of USE-2 and TC cables and wire, they are usually connected to less expensive cable at the first junction box leading to an

interior location. In many cases, a PV combiner as shown in Figure 7 is used to make the transition from the single conductor module wiring to one of the standard wiring methods. All PV system wiring **must** be made using one of the specific installation/materials methods included in the *NEC* [690.31, Chapter 3]. Single-conductor, exposed wiring is not permitted except for module wiring or with special permission [Chapter 3]. The most common methods used for PV systems are individual conductors in electrical metallic tubing (EMT) [358], rigid nonmetallic conduit (RNC) [352], or liquidtight flexible nonmetallic conduit (LFNC) [356].

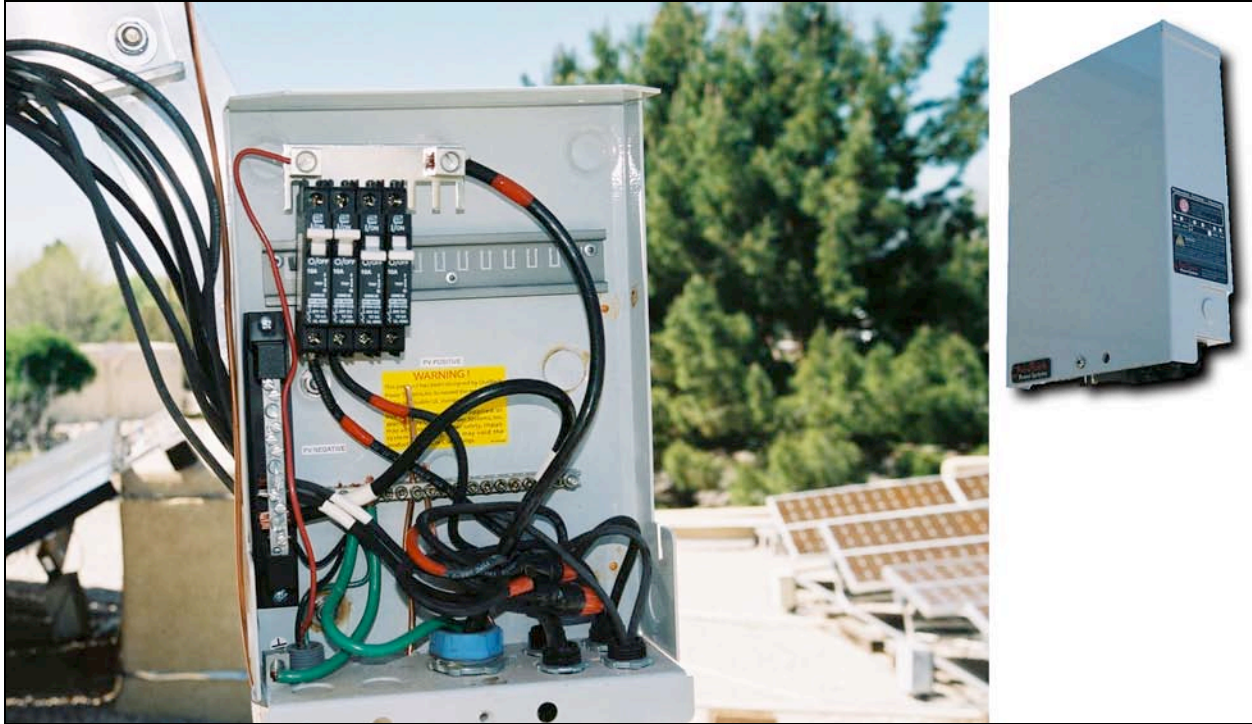

Figure 7. PV Combiner with Circuit Breakers

Where individual conductors are used in conduit installed in outdoor, sunlit locations, they should be conductors with at least 90°C insulation such as RHW-2, THW-2, THWN-2 or XHHW-2. Conduits installed in exposed locations are considered to be installed in wet locations [100-Locations (wet, damp, dry)]. These conduits may have water trapped in low spots and therefore only conductors with wet ratings are acceptable in conduits that are located in exposed or buried locations. The conduit can be either thick-wall (rigid, galvanized-steel, RGS, or intermediate, metal-conduit, IMC) or thin-wall electrical metallic tubing (EMT) [358], and if rigid nonmetallic conduit is used, electrical (gray) PVC (Schedule 40 or Schedule 80) rather than plumbing (white) PVC tubing **must** be used [352].

Two-conductor (with ground) UF cable (a jacketed or sheathed cable) or tray cable (type TC) that is marked sunlight resistant is sometimes used between the module interconnect wiring and the PV disconnect device.

Interior exposed cable runs can also be made with sheathed, multi-conductor cable types such as NM, NMB, and UF. The cable should not be subjected to physical abuse. If abuse is possible, physical protection **must** be provided [300.4, 334.15(B), 340.12]. *Exposed*, single-conductor cable (commonly used improperly between batteries and inverters) **shall not** be used—except as module interconnect conductors [300.3(A)]. Battery-to-inverter cables are normally single-conductor cables installed in conduit.

PV conductors **must not** be routed through attics unless they are installed in a metallic raceway between the point of first penetration of the building structure and the first dc disconnect [690.14, 690.31(E)]. Attic temperatures will be at higher-than-outdoor temperatures due to solar heating, and the ampacity of the conductors will have to be derated for these elevated temperatures. However, due to the PV disconnect location requirements established by *NEC* Section 690.14, conductors routed through attics are becoming less frequent. The *2005 NEC* allows conductors to be routed through the structure when they are installed in metallic raceways. [690.31(E)]

MODULE CONNECTORS

Module connectors that are concealed at the time of installation **must** be able to resist the environment, be polarized, and be able to handle the short-circuit current. They **shall** also be of a latching design with the terminals guarded. The equipment-grounding member, if used, **shall** make first and break last [690.32, 33]. *UL Standard 1703* also requires that the connectors for positive and negative conductors should not be interchangeable.

MODULE CONNECTION ACCESS

All junction boxes and other locations where module wiring connections are made **shall** be accessible. Removable modules and stranded wiring may allow accessibility [690.34]. The modules should not be permanently fixed (welded) to mounting frames, and solid wire that could break when modules are moved to service the junction boxes should be used sparingly. Open spaces behind the modules would allow access to the junction boxes.

SPLICES

All splices (other than the connectors mentioned above) **must** be made in approved junction boxes with an approved splicing method [300.15]. Conductors **must** be twisted firmly to make a good electrical and mechanical connection, then brazed, welded, or soldered, and then taped [110.14(B)]. Mechanical splicing devices such as split-bolt connectors or terminal strips are also acceptable. Crimped splicing connections may also be made if listed splicing devices and listed, heavy-duty crimping tools are used. Splices in the module conductors where made of jacketed two-conductor UF or TC cable when located outside **must** be protected in rain-proof junction boxes such as NEMA type 3R [300.15]. Cable clamps **must** also be used [300.15(C)]. Figure 8 shows some common

splicing devices. Many of the “power blocks” (on the left) are only “Recognized” by UL for use inside factory-assembled, listed devices. These “Recognized” devices are not suitable for installation or assembly in the field.

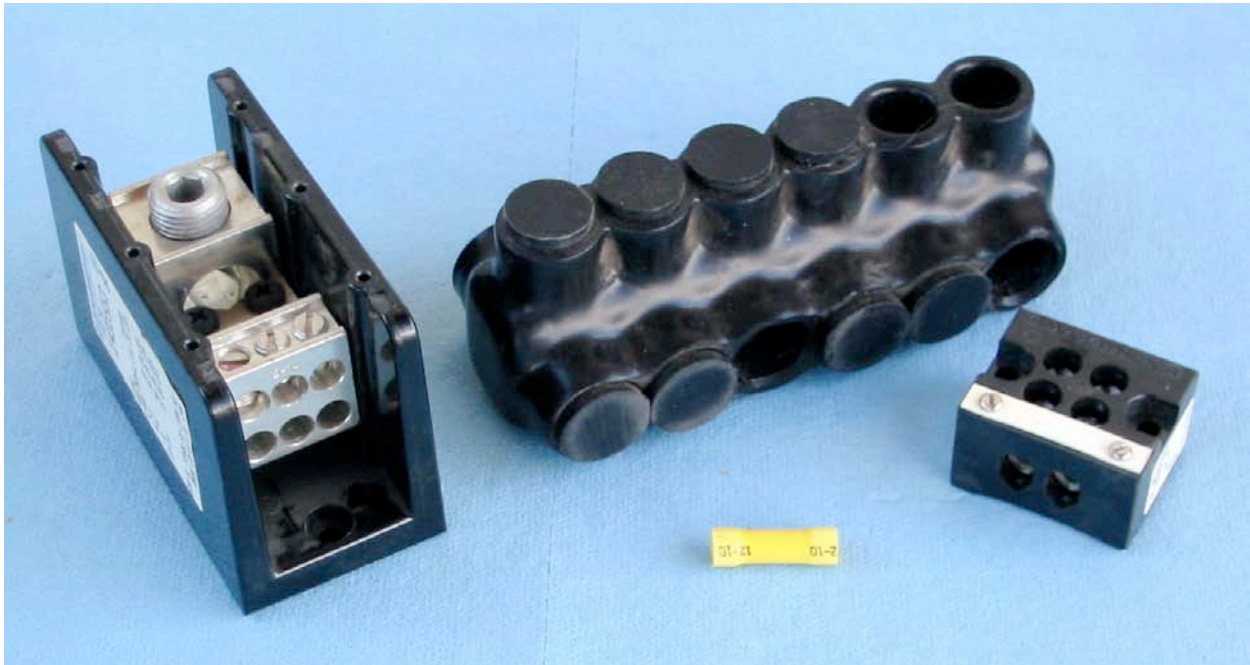

Figure 8. Common Splicing Devices

Splices can be exposed in exposed single-conductor USE-2 cables and may be made by soldering and covering the splice with appropriate heat shrink tubing listed for outdoor use containing sealant. The electrical and mechanical properties of the spliced conductor and the insulation around the splice **must** equal or exceed the unspliced conductor. Inline mechanical crimped splices may be used when listed for the application and installed with appropriately rated insulation listed for outdoor applications.

Properly used box-type mechanical terminal connectors (Figures 6 and 8) give high reliability. If used, they should be listed for at least damp conditions even when used in rainproof enclosures. However, few are listed for use with any type of conductor other than the normal Class B stranded wires (7 and 19 strands). Fuse blocks, fused disconnects, and circuit breakers frequently have these mechanical pressure terminals.

Twist-on wire connectors (approved for splicing wires), when listed for the environment (dry, damp, wet, or direct burial), are acceptable splicing devices. Unless specifically marked for ac only, they may be used on either ac or dc circuits. In most cases, they **must** be used inside enclosures, except when used in direct-burial applications [110.3(B), 310.15].

Where several modules are connected in series and parallel, a terminal block or bus bar arrangement **must** be used so that one source circuit can be disconnected

without disconnecting the grounded (on grounded systems) conductor of other source circuits [690.4(C)]. On grounded systems, this indicates that the popular “Daisy Chain” method of connecting modules may not always be acceptable, because removing one module in the chain may disconnect the grounded conductor for all of those modules in other parallel chains or source circuits. This becomes more critical on larger systems where paralleled sets of long series strings of modules are used. Figure 9 shows unacceptable and acceptable methods. The required module-protective fuse or other overcurrent device is usually required on each module (12-volt systems) or string of modules.

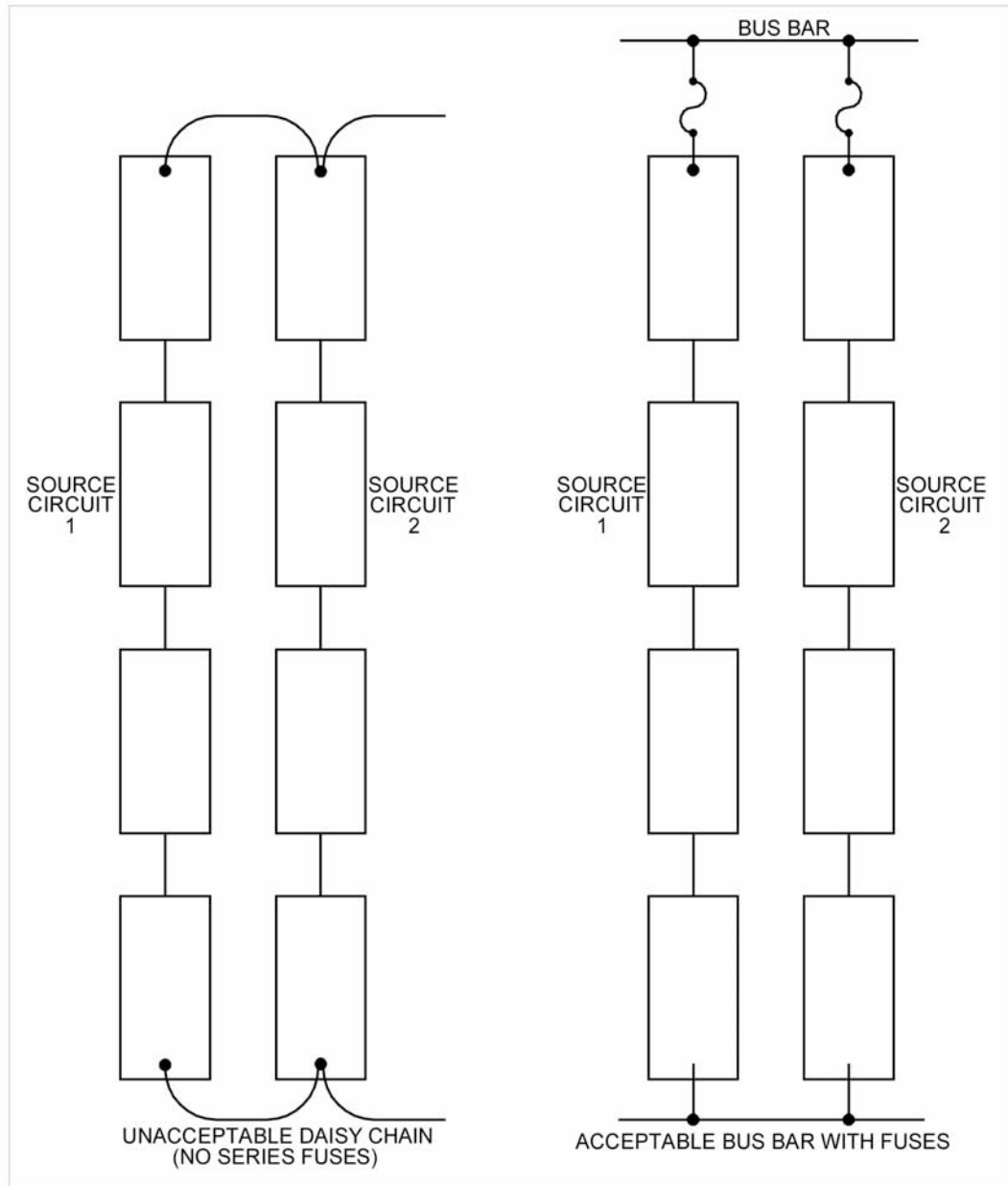

Figure 9. Module Interconnect Methods

CONDUCTOR COLOR CODES

The *NEC* established color codes for electrical power systems many years before either the automobile or electronics industries had standardized color codes. PV systems are being installed in an arena covered by the *NEC* and, therefore, **must** comply with *NEC* standards that apply to both ac and dc power systems. In a system where one conductor is grounded, the insulation on all grounded conductors **must** be white, gray or have three white stripes or be any color except green if marked with white plastic tape or paint at each termination (marking allowed only on conductors larger than 6 AWG). Conductors used for module frame grounding and other exposed metal equipment grounding **must** be bare (no insulation) or have green or green with yellow-striped insulation or identification [200.6, 7; 210.5; 250.119]. Any insulated equipment-grounding conductor used to ground PV module frames must be an outdoor-rated conductor such as USE-2.

The *NEC* requirements specify that the grounded conductor be white. In most PV-powered systems that are grounded, the grounded conductor is the negative conductor. Telephone systems that use positive grounds require special circuits when powered by PV systems that have negative grounds. In older PV systems where the array is center tapped, the center tap **must** be grounded [690.41], and this becomes the white conductor. There is no *NEC* requirement designating the color of the ungrounded conductor, but the convention in ac power wiring is that the first two ungrounded conductors are colored black and red. This suggests that in two-wire, negative-grounded PV systems, the positive conductor could be red or any color with a red marking except green or white, and the negative grounded conductor **must** be white. In a three-wire, center-tapped system, the positive conductor could be red, the grounded, center tap conductor **must** be white, and the negative conductor could be black.

The *NEC* allows grounded PV array conductors, such as non-white USE/USE-2, UF or SE that are smaller than 6 AWG, to be marked with a white marker [200.6(A)(2)].

PV ARRAY GROUND-FAULT PROTECTION

Article 690.5 of the *NEC* requires a ground-fault detection, interruption, and array disconnect (GFPD) device for fire protection if the PV arrays are mounted on roofs of dwellings. Ground-mounted arrays are not required to have this device. Several external devices or devices built into utility-interactive inverters are available that meet this requirement. These particular devices generally require that the system grounding electrode conductor be routed through or connected to the device. These devices include the following code-required functions:

- Ground-fault detection
- Ground-fault current interruption
- Array disconnect/inverter shutdown
- Ground-fault indication

Ground-fault detection, interruption, and indication devices might, depending on the particular design, accomplish the following actions automatically:

- Sense ground-fault currents exceeding a specified value
- Interrupt the fault currents
- Open the circuit between the array and the load
- Indicate the presence of the ground fault

Ground-fault devices have been developed for both grid-tied inverters (Figure 11) and stand-alone systems (Figure 12), and others are under development. See Appendix H for more details.

The 1999 *NEC* added a Section 690.6(D) *permitting* (not requiring) the use of a device (undefined) on the ac branch circuit being fed by an ac PV module to detect ground-faults in the ac wiring. There are no commercially available devices as of mid 2004 that meet this permissive requirement. Standard 5-milliamp anti-shock receptacle GFCIs or 30-milliamp equipment protection circuit breakers should not be used for this application. The receptacle GFCIs interrupt both the hot (ungrounded) and neutral (grounded) conductor, and the equipment protection circuit breaker may be destroyed when backfed.

The 2005 *NEC* will allow ungrounded PV arrays and the requirements for ground-fault protection will differ slightly from these requirements for grounded systems. See Appendix L.

PV ARRAY INSTALLATION AND SERVICE

Article 690.18 requires that a mechanism be provided to allow safe installation or servicing of portions of the array or the entire array. The term "disable" has several meanings, and the *NEC* is not clear on what is intended. The *NEC* Handbook does elaborate. "Disable" can be defined several ways:

- Prevent the PV system from producing any output
- Reduce the output voltage to zero
- Reduce the output current to zero
- Divide the array into non-hazardous segments

The output could be measured either at the PV source terminals or at the load terminals.

Fire fighters are reluctant to fight a fire in a high-voltage battery room because there is no way to turn off a battery bank unless the electrolyte can somehow be removed. In a similar manner, the only way a PV system can have zero output at the array terminals is by preventing light from illuminating the modules. The output voltage may be reduced to zero by shorting the PV module or array terminals. When this is done, short-circuit current will flow through the shorting conductor which, in a properly wired system, does no harm. The output current may be reduced to zero by disconnecting the PV array from the rest of the system. The PV disconnect switch would accomplish this action, but open-circuit voltages would still be present on the array wiring and in the disconnect box. In a large system, 100 amps of short-circuit current (with a shorted array) can be as difficult to handle as an open-circuit voltage of 600 volts.

During PV module installations, the individual PV modules can be covered to disable them. For a system in use, the PV disconnect switch is opened during maintenance, and the array is either short circuited or left open circuited depending on the circumstances. In practical terms, for a large array, some provision (switch or bolted connection) should be made to disconnect portions of the array from other sections for servicing. As individual modules or sets of modules are serviced, they may be covered and/or isolated and shorted to reduce the potential for electrical shock. Aside from measuring short-circuit current, there is little that can be serviced on a module or array when it is shorted. The circuit is usually open circuited for repairs.

The code requirement that the PV source and output conductors be kept outside the building until the readily accessible disconnect is reached indicate that these conductors are to be treated in a manner similar to ac service entrance conductors [690.14]. First response personnel are less likely to cut these energized cables since they are on the outside of the building. The *2005 NEC* allows PV source and output circuits inside the building providing that they are installed in a metallic raceway [690.31(E)].

Even in dim light conditions (clouds, dawn, dusk) when sunlight is not directly illuminating the PV module or PV array, voltages near the open-circuit value will appear on PV source and output circuit wiring. Distributed leakage paths caused by dirt and moisture will ground-reference, supposedly ungrounded, disconnected conductors, and they may be energized with respect to ground posing a safety hazard.

GROUNDING

DEFINITIONS

The subject of grounding is one of the most complex issues in electrical installations. Definitions from Articles 100 and 250 of the *NEC* will help to clarify the situation when grounding requirements are discussed.

Grounded:	Connected to the earth or to a metallic conductor or surface that serves as earth.
Grounded Conductor: (white or gray or three white stripes)	A system conductor that normally carries current and is intentionally grounded. In PV systems, one conductor (normally the negative) of a two-conductor system or the center-tapped conductor of a bipolar system is grounded.
Equipment Grounding Conductor: (bare, green, or green with yellow stripe)	A conductor not normally carrying current used to connect the exposed metal portions of equipment that might be accidentally energized to the grounding electrode system or the grounded conductor.
Grounding Electrode Conductor:	A conductor not normally carrying current used to connect the grounded conductor to the grounding electrode or grounding electrode system.
Grounding Electrode	The conducting element in contact with the earth (e.g., a ground rod, a concrete-encased conductor, grounded building steel, and others).

GROUNDING—SYSTEM

For a two-wire PV system over 50 volts (125% of open-circuit PV-output voltage), one dc current-carrying conductor **shall** be grounded. In a three-wire

system, the neutral or center tap of the dc system **shall** be grounded [690.41]. These requirements apply to both stand-alone and grid-tied systems. Such system grounding will enhance personnel safety and minimize the effects of lightning and other induced surges on equipment. In addition, the grounding of all PV systems (even 12-volt systems) will reduce radio frequency noise from dc-operated fluorescent lights and inverters.

Size of DC Grounding Electrode Conductor

Section 250.166 of the *NEC* addresses the size of the dc grounding electrode conductor (GEC). Many PV systems can use a 6 AWG GEC if that is the *only connection* to the grounding electrode [250.166(C)] and that grounding electrode is a rod, pipe, or plate electrode. In some cases (a very small system with circuit conductors less than 8 AWG), an 8 AWG GEC may be used and should be installed in conduit for physical protection. Many inspectors will allow a 6 AWG GEC to be used without additional physical protection. Other grounding electrodes will require different sizes of grounding electrode conductors. In a few cases, the direct-current system-grounding electrode conductor **shall not** be smaller than 8 AWG or the largest conductor supplied by the system [250.166(B)]. If the conductors between the battery and inverter are 4/0 AWG (for example) then the grounding-electrode conductor from the negative conductor (assuming that this is the grounded conductor) to the grounding electrode may be required to be as large as 4/0 AWG. However, in most PV installations, a smaller GEC (usually 6 AWG) will be allowed if it is connected only to a rod, pipe, or plate electrode [250.166(C)].

If the grounding electrode were a concrete-encased conductor, then a 4 AWG GEC would be required. [250.66(B), 250.166(D)]

Point of Connection

In stand-alone systems, primarily, the system grounding electrode conductor for the direct-current portion of a PV system **shall** be connected to the PV-output circuits [690.42] at a single point. When this connection (the dc bonding point) is made close to the modules, added protection from surges is afforded. However, real-world considerations affect this connection point.

In stand-alone PV systems, the charge controller may be considered a part of the PV-output circuit, and the point-of-connection of the grounding electrode conductor could be before or after the charge controller. However, this grounding conductor may be a very large conductor (e.g., 4/0 AWG) while the conductors to and from the charge controller may be 10 AWG or smaller. Connecting the 4/0 AWG grounding conductor on the array side of the charge controller, while providing some degree of enhanced surge suppression from lightning induced surges, may not meet the full intent of the grounding requirements. Connecting the grounding conductor to the system on the battery side of the charge controller at a

point where the system conductors are the largest size will provide better system grounding at the expense of less lightning protection. Since the *NEC* allows smaller grounding electrode conductors in many circumstances, either grounding conductor point of connection may be acceptable [250.166]. Figure 10 shows two possible locations for the grounding electrode conductor.

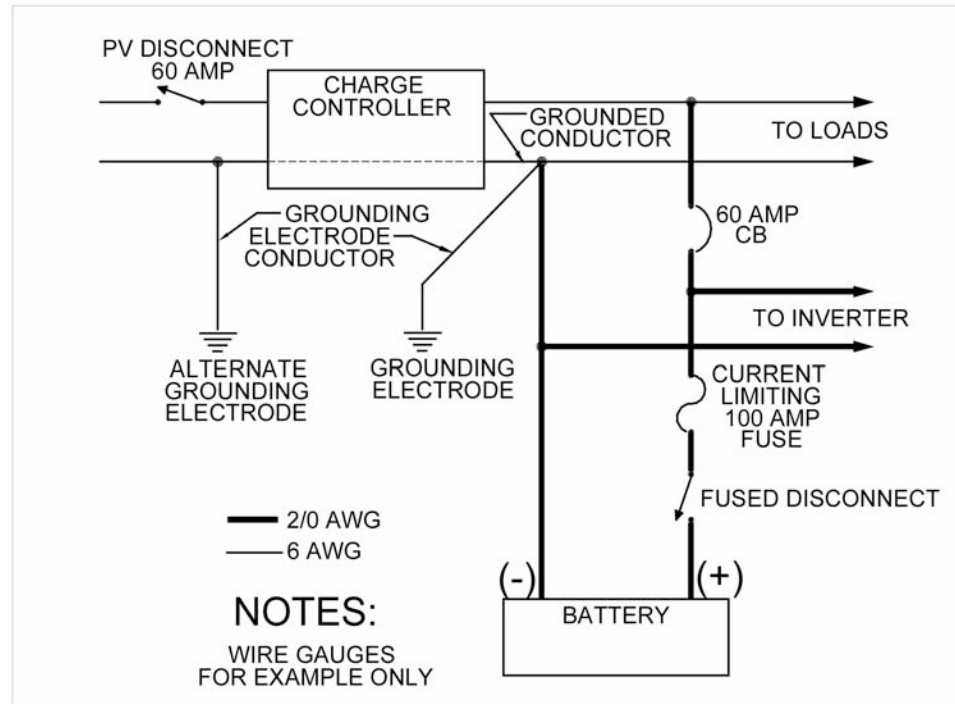

Figure 10. Typical System: Possible Grounding Conductor Locations

The *NEC* does not specifically define where the PV-output circuits end. Circuits from the battery toward the load are definitely load circuits. Since the heaviest conductors are from the battery to the inverter, and either end of these conductors is at the same potential, then either end could be considered a point for connecting the grounding conductor. The negative dc input to the inverter is connected to the metal case in some unlisted stand-alone inverter designs, but this is not an appropriate place to connect the grounding electrode conductor and other equipment-grounding conductors, since this circuit is a dc-branch circuit and not a PV-output circuit. Connection of the grounding electrode conductor to or near the negative battery terminal would avoid the “large-wire/small-wire” problem outlined above.

However, the presence of ground-fault protection devices [690.5] may dictate that this bonding point be made in the ground-fault device or inside the inverter. Many utility-interactive inverters have internal ground-fault protection devices that dictate the connection point for the dc grounding electrode conductor. Figure 11 shows a utility-interactive inverter

installation where the grounding electrode conductor is connected to a point inside the inverter and the inverter furnishes the bond to the grounded conductor.



Figure 11. Utility-Interactive Inverter with Internal DC Bonding Point, GFPD, and Connection Point for Grounding Electrode Conductor

It is imperative that there be no more than one ground connection to the dc grounded conductor of a PV system. Failure to limit the connections to one (1) will allow objectionable currents to flow in uninsulated equipment-grounding conductors and will create unexpected ground faults in the grounded conductor [250.6]. The ground-fault protection systems will sense these extra connections as ground faults and may not function correctly. There are exceptions to this rule when PV arrays, generators, or loads are some distance from the main loads [250.32].

Unusual Grounding Situations

Some unlisted stand-alone inverter designs use the entire chassis as part of the negative circuit. Also, the same situation exists in certain radios—automobile and shortwave. These designs will not pass the current UL standards for consumer electrical equipment or PV systems and will probably require modification in the future since they do not provide

electrical isolation between the exterior metal surfaces and the current-carrying conductors. They also create the very real potential for multiple grounded-conductor connections to ground.

Since the case of these non-listed inverters and other non-listed products is connected to the negative conductor and that case **must** be grounded as part of the equipment ground described below, the user has no choice whether or not the *system* is to be grounded [250 VI]. The system is grounded even if the voltage is less than 50 volts and the point of system ground is the negative input terminal on the inverter. It is strongly suggested that these unlisted inverters not be used and, in fact, to use them or any unlisted component may result in the inspector not accepting the system.

Some telephone systems ground the positive conductor, and this may cause problems for PV-powered telephone systems with negative grounds. An isolated-ground, dc-to-dc converter may be used to power subsystems that have different grounding polarities from the main system. In the ac realm, an isolation transformer will serve the same purpose.

In larger utility-tied systems and some stand-alone systems, high impedance grounding systems or other methods that accomplish equivalent system protection and that use equipment listed and identified for the use might be used in lieu of, or in addition to, the required hard ground [690.41]. The discussion and design of these systems are beyond the scope of this guide. Grounding of grid-tied systems will be discussed later in this manual.

Charge Controllers—System Grounding

In a grounded system, it is important that the charge controller does not have electronic devices or relays in the grounded conductor. Charge controllers listed to the current edition of UL *Standard 1741* meet this requirement. Relays or transistors in the grounded conductor create a situation where the grounded conductor is not at ground potential at times when the charge controller is operating. This condition violates provisions of the *NEC* that require all conductors identified as grounded conductors always be at the same potential (i.e. grounded). A shunt in the grounded conductor is equivalent to a wire, if properly sized, but the user of such a charge controller runs the risk of having the shunt bypassed when inadvertent grounds occur in the system. The best charge controller design has only a straight-through conductor between the input and output terminals for the grounded current-carrying conductor (usually the negative conductor).

Ungrounded Systems

Section 690.35 of the 2005 *NEC*, will permit (not require) ungrounded PV systems when a number of conditions are met. These conditions are intended to make ungrounded PV installations in the United States as safe as equivalent ungrounded PV systems in Europe. Given the 100+-year history of grounded electrical systems, the U.S. PV industry and the electricians and inspectors may not have the experience, knowledge, and infrastructure to properly and safely install and inspect ungrounded PV systems. The *NEC* requirements were developed to bring the US PV industry in line with the rest of the world by adopting some of the European techniques and experience for installing ungrounded systems. They include:

- Overcurrent protection and disconnects on all circuit conductors
- Ground-fault protection on all systems
- Jacketed or sheathed multiconductor cables or raceways
- Additional warning labels
- Inverters listed specifically for this use

EQUIPMENT GROUNDING

All non-current-carrying exposed metal parts of junction boxes, equipment, and appliances in the entire electrical system that may be accidentally energized **shall** be grounded [690.43; 250 VI; 720.10]. All PV systems, regardless of voltage, **must** have an equipment-grounding system for exposed metal surfaces (e.g., module frames and inverter cases) [690.43]. The equipment-grounding conductor **shall** be sized as required by Article 690.45 or 250.122. Generally, this will mean an equipment-grounding conductor (in other than PV source and output circuits) based on the size of the overcurrent device protecting the ac or dc circuit conductors. Table 250.122 in the *NEC* gives the sizes. For example, if the inverter-to-battery conductors are protected by a 400-amp fuse or circuit breaker, then at least a 3 AWG conductor **must** be used for the equipment ground for that circuit [Table 250.122]. If the current-carrying conductors have been oversized to reduce voltage drop, then the size of the equipment-grounding conductor **must** also be proportionately adjusted [250.122(B)].

In the PV source and output circuits, the equipment grounding conductors should generally be sized to carry at least 125% of the short-circuit currents from the PV circuits (not including backfeed currents from other sources) at that point in the circuit. They should not be less than 14 AWG to afford some degree of mechanical strength—particularly when they are installed between modules in free air. Where the circuit conductors are oversized for voltage drop, the equipment-grounding conductor shall be proportionately oversized in accordance with 250.122(B) except where there are no overcurrent devices protecting the circuit as allowed by 690.9 EX. [690.45]. See Appendix G for additional details on grounding PV modules.

If exposed, single-conductor cables are run along and adjacent to metal racks, then these racks may be subject to being energized and should be grounded. Installations using conductors in conduits may not seem to require grounded racks since the module grounding and the conduit grounding (if metallic conduits were used) would provide the code-required protection. However, modules have been known to shatter and conductive elements come into contact with the racks, therefore the racks should also be grounded. Frequently, module racks are grounded to provide additional protection against lightning.

INVERTER AC OUTPUTS

The inverter output (120 or 240 volts) **must** be connected to the ac distribution system in a manner that does not create parallel paths for currents flowing in grounded conductors [250.6]. The *NEC* requires that both the green or bare equipment-grounding conductor and the white ac neutral conductor be grounded, and this is normally accomplished by the ac distribution equipment or load center and not in the inverter. The Code also requires that current not normally flow in the equipment-grounding conductors. If the stand-alone inverter has ac grounding receptacles as outputs, the equipment-grounding and neutral conductors are most likely connected to the chassis and, hence, to chassis ground inside the inverter. This configuration allows plug-in devices to be used safely. However, if the outlets on the inverter are plug and cord connected (not allowed) to an ac load center used as a distribution device, then problems can occur.

The ac load center usually has the grounded neutral and equipment-grounding conductors connected to the same bus bar. This bus bar is also connected to the enclosure and has a grounding electrode conductor connected to a grounding electrode. Parallel current paths are created with neutral currents flowing in the equipment-grounding conductors when the inverter also has the neutral bonded to the equipment-grounding conductor. This problem can be avoided (where stand-alone inverters with internal bonding are used) by using a load center with an isolated/insulated neutral bus bar that is separated from the equipment-grounding bus bar.

Inverters with hard-wired outputs may or may not have internal bonding connections. Most listed stand-alone inverters and all utility-interactive inverters do not have an internal neutral-to-ground bond. Some stand-alone inverters with ground-fault circuit interrupters (GFCIs) for ac outputs **must** be connected in a manner that allows proper functioning of the GFCI [110.3(B)]. A case-by-case analysis will be required.

PV INVERTERS CREATE SEPARATELY DERIVED SYSTEMS

PV systems will generally have dc circuits and ac circuits and both **must** be properly grounded [250, 690 V]. Although the *NEC* has parts of Article 250 that deal with the grounding of ac systems and parts that deal with the proper grounding of dc systems, it does not specifically deal with systems that have both ac and dc components.

In Article 100 of the *NEC*, the definition of “Separately Derived Systems” includes PV systems, and in most cases this is correct. Most, but not all, PV systems (both stand-alone systems and utility-interactive systems) employ an inverter that converts the dc from the PV modules to ac that is used to feed loads or the utility grid. These inverters use a transformer that isolates the dc side of the system from the ac side. The grounded dc circuit conductor is not directly connected to the grounded ac circuit conductor. Although the normal definition of separately derived systems applies only to ac systems with transformers, in fact, the isolation between ac and dc circuits in PV inverters makes many PV systems also separately derived systems.

AC Grounding

As in any separately derived system, both parts **must** be properly grounded [250.30]. There is usually no internal bond between the ac grounded circuit conductor and the grounding system inside either stand-alone or utility-interactive inverters. Both of these PV systems rely on the neutral-to-ground main bonding jumper in the service equipment (utility-interactive systems) or the bonding jumper in the first load center (stand-alone systems) for grounding the ac side of the system.

DC Grounding

The dc side of the system **must** also be grounded when the system voltage (open-circuit PV voltage times a temperature-dependent constant) is above 50 volts. See *NEC* Section 690.41 for more details. *NEC* Table 690.7 gives the temperature-dependent constant, and the application of this constant usually indicates that PV systems with a nominal voltage of 24-volts or greater **must** have the dc side grounded. Only infrequently are 12-volt dc systems found that do not have one of the dc circuit conductors grounded, and even those systems **must** have an equipment-grounding system [690.43]. Most of the 12-48 volt balance-of-systems PV equipment is designed to be used only with a grounded system. See *NEC* Section 690.43. Nearly all utility-interactive PV systems operate with a nominal voltage of 48 volts or higher so they **must** have one of the dc circuit conductors grounded [690.41], although some ungrounded systems will be permitted [690.31(E)], when the 2005 *NEC* is applied.

Properly grounding the dc side of a PV system is somewhat complicated by Section 690.5 of the *NEC* that requires a ground-fault protection device (GFPD) on some PV systems. Many utility-interactive inverters have an internal GFPD (Figure 11). Inverters (both stand-alone and utility-interactive) that are used in systems with PV modules mounted on the roofs of dwellings that do not have the internal GFPD **must** have an external GFPD installed in the system [690.5]. See Figure 12. In nearly all cases, these GFPDs (either inside the inverter or externally mounted) actually make the grounded circuit conductor-to-ground bond.



Figure 12. External Ground-Fault Protection Device

For systems employing a GFPD, there should be no external bonding conductor, and to add one to these systems would bypass the GFPD and render it inoperative.

In most dc systems, the negative conductor is the grounded conductor.

A dc bond inside the inverter with a GFPD or a dc bond in a GFPD external to the inverter establishes the need for, and connection location of, a dc grounding electrode conductor. Some inverters with an internal GFPD have a terminal designated for connecting the usual 8 AWG to 4 AWG grounding electrode conductor. Other inverters lack this connection. Some inverter manufacturers provide a field-installed lug kit for this connection that has been evaluated by their listing agency. PV systems with an externally installed GFPD will have an appropriate connection place (and instructions) for the grounding electrode conductor.

PV systems that do not have PV modules mounted on the roofs of dwellings are not required to have the GFPD that is required in Section 690.5, but many inverters in those systems will have it anyway. In those systems not requiring or having a GFPD, the dc bonding jumper may be installed at any single point on the PV output circuits, and this is where the dc grounding electrode conductor should be connected.

BACKUP GENERATORS

Backup ac generators used for battery charging pose problems similar to using inverters and load centers. Many of these smaller generators usually have ac outlets that may have the neutral and grounding conductors bonded to the

generator frame. When the generator is connected to the system through a load center to a stand-alone inverter with battery charger, or to an external battery charger, parallel ground paths are likely. These problems need to be addressed on a case-by-case basis. A stand-alone PV system, in any operating mode (inverting or battery charging), **must not** have currents in the equipment-grounding conductors [250.6].

In some cases, manual or automated transfer switches **must** be used that switch both the grounded neutral conductor as well as the ungrounded circuit conductor [250.6]. In some cases, this neutral switching can eliminate the double bonding points.

Utility-interactive PV systems with batteries and possibly backup generators may have similar or more complex grounding and bonding issues.

SUGGESTED AC GROUNDING

Auxiliary ac generators and inverters should be hard-wired to the ac-load center. Neither should have an internal bond between the neutral and grounding conductors. Neither should have any receptacle outlets that can be used when the generator or inverter is operated when disconnected from the load center. The single bond between the neutral and ground should be made in the system ac load center. If receptacle outlets are desired on the generator or the inverter, they should be ground-fault-circuit-interrupting devices (GFCI).

Section 250.32 of the *NEC* presents alternate methods of achieving a safe grounding system in a limited number of installations where the various parts of the system (generator, PV modules, dc load center, and inverter) are remotely located from each other.

GROUNDING ELECTRODE

The dc system grounding electrode **shall** be common with, or bonded to, the ac grounding electrode (if any) [690.47, 250 III]. The dc system grounded conductor and the equipment-grounding conductors **shall** be tied to the same grounding electrode or grounding electrode system. The conductors are usually first connected by a main dc bonding jumper and then a grounding electrode conductor is run from the bonding point to the grounding electrode. Even if the PV *system* is ungrounded (optional at less than 50 volts [typically 125% of V_{oc}]), equipment-grounding conductors **must** be used and **must** be connected to a grounding electrode [250.110]. Metal water pipes and other metallic structures as well as concrete encased electrodes are to be used in some circumstances [250.50]. When a manufactured grounding electrode is used, it **shall** be a corrosion resistant rod, a minimum of 5/8 inch (16mm) in diameter (1/2 inch (13mm) if stainless steel)) with at least 8 feet (2.4m) driven into the soil at an angle no greater than 45 degrees from the vertical [250.53]. Listed connectors **must** be used to connect the grounding electrode conductor to the ground rod [110.3(B)].

A bare-metal well casing makes a good grounding electrode. It should be part of a grounding electrode system. The central pipe to the well should not be used for grounding, because it is sometimes removed for servicing.

For maximum protection against lightning-induced surges, it is suggested that a grounding electrode **system** be used with at least two grounding electrodes. One electrode would be the main-system grounding electrode as described above. The other would be a supplementary grounding electrode located as close to the PV array as practical. The module frames and array frames would be connected directly to this grounding electrode to provide as short a path as possible for lightning-induced surges to reach the earth. This electrode is usually not bonded to the main system grounding electrode [250.54]. This supplementary ground rod is an auxiliary to the module frame grounding that is required to be connected with an equipment-grounding conductor connected to the main grounding electrode as discussed in the section on Equipment Grounding, above.

Do not connect the negative current-carrying conductor to the grounding electrode, to the equipment-grounding conductor, or to the module or array frame at the modules. *There should be one and only one point in the system where the dc grounding electrode conductor is attached to the dc system grounded conductor.* See Figure 13 for clarification. The wire sizes shown are for illustration only and will vary depending on system size. Chapter 3 of the *NEC* specifies the ampacity of various types and sizes of conductors. As is common throughout the *NEC*, there are exceptions to this guidance. See *NEC* Section 250.32(B).

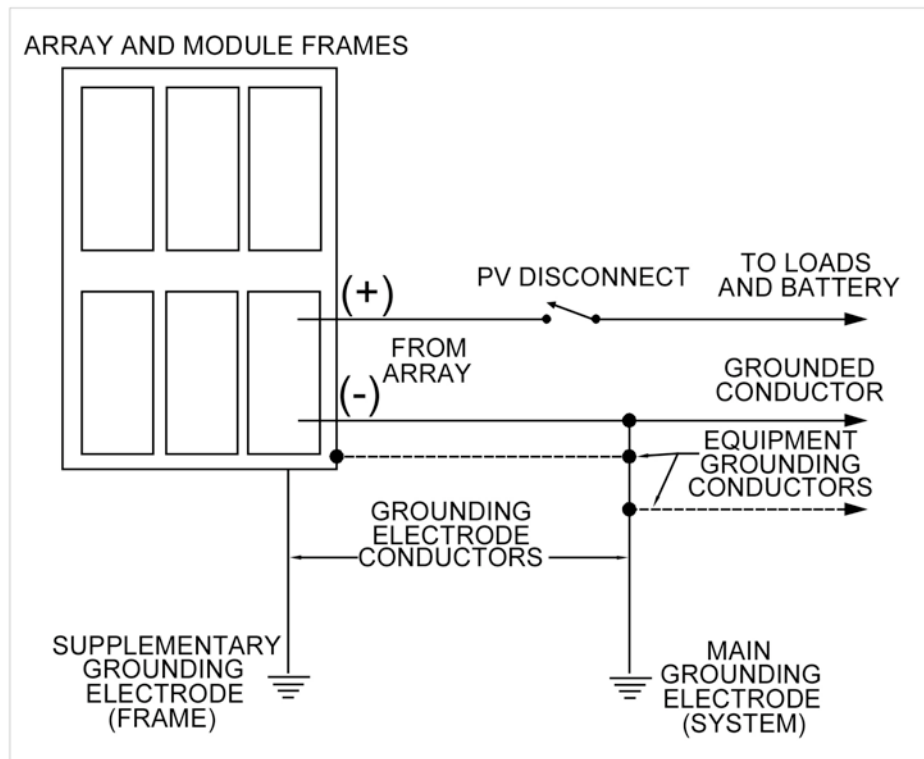

Figure 13. Example Grounding Electrode System

CONDUCTOR AMPACITY

NEC Tables 310.16 and 310.17 give the ampacity (current-carrying capacity in amps) of various sized conductors at temperatures of 30°C (86°F). There are several adjustments that normally **must** be made to these ampacity numbers before a conductor size can be selected [310.15].

The installation method **must** be considered. Are the conductors in free air [Table 310.17] or are they bundled together or placed in conduit [Table 310.16]?

What is the ambient air temperature, if not 30°C (86°F)?

How many current-carrying conductors are grouped together?

These adjustments are made using factors presented in Chapter 3 of the *NEC*.

Additionally, most conductors used in electrical power systems are restricted from operating on a continuous basis at more than 80% of their rated ampacity [210.19, 215.2, 690.8]. This 80% factor also applies to overcurrent devices and switchgear unless listed for operation at 100% of rating [210.20(A)]. PV conductors are also restricted by this factor ($0.8=1/1.25$) [690.8(B)].

Conductors carrying PV module currents are further restricted by an additional derating factor of 80% because of the manner in which PV modules generate electrical energy in response to sunlight and because the noon-time intensity of the sunlight may exceed the standard test condition value of 1000 W/m² [690.8(A)]. Also, nearby reflective surfaces (sand, snow, and water) may enhance the solar intensity on the module and increase its output.

It should be noted that these ampacity adjustment factors may be applied to the basic conductor ampacities (e.g., multiply them by 0.80) or they may be applied to the anticipated current in the circuit (e.g., multiply the current by 1.25, the reciprocal of 0.8).

Photovoltaic modules are limited in their ability to deliver current. The short-circuit current capability of a module is nominally 10 to 15% higher than the operating current. Normal, daily values of solar irradiance may exceed the standard test condition of 1000W/m². These increased currents are considered by using the 1.25 adjustment in the ampacity calculations. Another design requirement for PV systems is that the conductors connected to PV modules or in contact with the back of PV modules may operate at temperatures as high as 75-80°C when the modules are mounted close to a structure, there are no winds, and the ambient temperatures are high. Temperatures in module junction boxes frequently occur within this range. This will require that the ampacity of the conductors be derated or corrected with factors given in *NEC* Table 310.16 or 310.17. For example, a 10 AWG USE-2/RHW-2 single-conductor cable used for module interconnections in conduit has a 90°C insulation and an ampacity of 40 amps in an ambient temperature of 26-30°C. When it is used in ambient temperatures of 61-70°C, the ampacity of this cable is reduced to 23.2 amps.

It should be noted that the ampacity values associated with conductors having 90°C insulation could only be used if the terminals of the module and connected terminal blocks or overcurrent devices are rated at 90°C [110.14(C)]. If the terminals are rated at only 75°C, then the ampacity values associated with 75°C insulation **must** be used, even when conductors with 90°C

insulation are being used. Of course, if the 90°C insulation wire is used, the temperature derating may start with the 90°C ampacity values. All module terminals are rated for use with 90°C conductors. However, there are no overcurrent devices rated for 90°C. Most overcurrent devices are marked for use with 75°C conductors, and if not marked and rated at less than 100 amps, must be used with conductors rated at 60°C or conductors limited to 60°C conductor ampacity levels [110.14(C)].

There are several rules that **must** be followed to determine the ampacity of conductors in a PV system.

1. The ampacity of conductors in PV source circuits **shall** be at least 125% of the rated module or parallel-connected modules *short-circuit current* rating [690.8].
2. The ampacity of the PV-output circuit conductors **shall** be at least 125% of the short-circuit output current [690.8(A)].
3. The ampacity of conductors to and from an inverter or power conditioning system **shall** be 125% of the rated operating current for that device [690.8(A)].
4. In a similar manner, other conductors in the system should have an ampacity of 125% of the rated operating current to allow for long duration operation at full power [215.2].

These *NEC* requirements are to ensure that the connected overcurrent devices or panelboards operate at no more than 80% of their ampacity. Operation when snow or cloud enhancement increases the PV output currents above normal, but these are generally short-term effects and are not considered in the ampacity calculations. Daily expected values of solar irradiance will exceed the standard test condition of 1000W/m² at many locations.

UL *Standard 1703* for PV modules requires that module installation instructions include an *additional 25%* of the 25°C ratings for short-circuit current and open-circuit voltage to allow for expected daily peak irradiance and colder temperatures. This 1.25 factor, while still in the 2002 edition of UL *Standard 1703*, is also contained in Section 690.8(A) of the *NEC* as mentioned above. There are only two 1.25 factors applied to PV module currents and the combined factor is 1.56 (1.25x1.25). Correct design practices require correctly determining wire size and the ampere rating of overcurrent devices on PV source and output circuits. However, the rating of the overcurrent device should always be less than, or equal to, the ampacity of the cable. The *NEC* makes only infrequent exceptions to this rule. [240.3].

The ampacity of conductors and the sizing of overcurrent devices is an area that demands careful attention by the PV system designer/installer. Temperatures and wiring methods **must** be addressed for each site [310.15]. Calculations start with the 125% of I_{sc} value to comply with the UL 1703 requirements [also in Section 690.8(A)], and additional 125% **must** then be used for code compliance [690.8. 690.9]. Finally, the cable ampacity is adjusted for temperature. See Appendix E for additional examples.

Overcurrent devices may have terminals rated for connection to 60°C conductors necessitating a reduction in the cable ampacity when using 75°C or 90°C conductors.

Appendix I summarizes the complex calculations required to properly calculate conductor sizes and overcurrent device ratings.

When the battery bank is tapped to provide multiple voltages (i.e., 12 and 24 volts from a 24-volt battery bank), the common negative conductor will carry the *sum* of all of the simultaneous load currents. The negative conductor **must** have an *ampacity at least equal to the sum* of all the amp ratings of the overcurrent devices protecting the positive conductors or have an ampacity equal to the sum of the ampacities of the positive conductors [690.8(C)].

The *NEC* does not allow paralleling conductors for added ampacity, except that cables 1/0 AWG or larger may be paralleled under certain conditions [310.4]. DC-rated switchgear, overcurrent devices, and conductors cost significantly more when rated to carry more than 100 amps. It is suggested that large PV arrays be broken down into subarrays, each having a short-circuit output of less than 64 amps. This configuration will allow the use of 100-amp-rated equipment (156% of 64 amps) on each source circuit.

STAND-ALONE SYSTEMS—INVERTERS

In stand-alone systems, inverters are used to change the direct current (dc) from a battery bank to 120-volt or 240-volt, 60-Hertz (Hz) alternating current (ac). The conductors between the inverter and the battery **must** have properly rated overcurrent protection and disconnect mechanisms [240, 690.8, 690.9]. These inverters frequently have short-duration (seconds) surge capabilities that are four to six times the rated output. For example, a 2,500-watt inverter might be required to surge to 10,000 volt-amps for 5 seconds when a motor load is started. The *NEC* requires the ampacity of the conductors between the battery and the inverter to be sized by the rated 2,500-watt continuous output of the inverter. For example, in a 24-volt system, a 2,500-watt inverter would draw 134 amps at full load (85% efficiency at 22 volts) and 420 amps for motor-starting surges. The required ampacity of the conductors between the battery and the inverter is 125% of the 134 amps or 167 amps.

To minimize steady-state voltage drops to account for surge-induced voltage drops and to increase system efficiency, some well-designed systems have conductors that are larger than required by the *NEC*. When the current-carrying conductors are oversized, the equipment-grounding conductor **must** also be oversized proportionately [250.122].

See Appendices F and I for additional considerations on conductor ampacity.

OVERCURRENT PROTECTION

The *NEC* requires that every ungrounded conductor be protected by an overcurrent device [240.20]. In a PV system with multiple sources of power (PV modules, batteries, battery chargers, generators, power conditioning systems, etc.), the overcurrent device **must** protect the conductor from overcurrent from any source connected to that conductor [690.9]. Blocking

diodes, charge controllers, and inverters are not considered as overcurrent devices and **must** be considered as zero-resistance wires when assessing overcurrent sources [690.9(A) FPN]. If the PV system consists of a single string of modules (or possibly two strings of modules) and is directly connected to the load without battery storage or other source of overcurrent, then no overcurrent protection is required if the conductors are sized at 156% of the short-circuit current [690.8(B)(1)EX].

Some utility-interactive inverters are not capable of back feeding utility currents into the faults in the PV array. With these inverters, one, two and possibly more strings of modules may be connected to the inverter with no overcurrent device at the inverter input. See Appendix J for more details.

When circuits are opened in dc systems, arcs are sustained much longer than they are in ac systems. This presents additional burdens on overcurrent-protection devices rated for dc operation. Such devices are required to carry the rated load current and sense overcurrent situations as well as be able to safely interrupt dc currents. AC overcurrent devices have the same requirements, but the interrupt function is considerably easier.

AMPERE RATING

The PV source circuits **shall** have overcurrent devices rated at least 156% (1.25 x 1.25) of the module short-circuit current. The PV-output circuit overcurrent devices **shall** be rated at least 156% of the short-circuit PV currents from the parallel connected modules or strings of modules [690.8]. Time-delay fuses or circuit breakers would minimize nuisance tripping or blowing. In all cases, dc-rated devices having the appropriate dc-voltage rating **must** be used. See Appendix I for more detailed information on the calculation of the ratings of overcurrent devices.

Overcurrent devices have standard ratings as follows: 15, 20, 25, 30, 35, 40, 45, 50, 60, 70, 80, 90, 100, 110, 125, 150, 175, 200, 225, 250, 300, 350, 400, 450, 500 amps and higher. [240.6(A)]. If a conductor has an ampacity that falls between one of the standard values, the next larger overcurrent device **shall** be used [240.4(B)]. However, in PV source and output circuits, the overcurrent device standard ratings for supplementary devices (where used) are in one-amp increments from 1 amp to 15 amps [690.9(C)]. At 15 amps and above, the standard values apply.

All ungrounded conductors from the PV array **shall** be protected with overcurrent devices [Article 240, Diagram 690.1]. Grounded conductors (not shown in Diagram 690.1) **must not** have overcurrent devices since the independent opening of such a device might unground the system. Since PV module outputs are current limited, these overcurrent devices are actually protecting the array wiring from backfeed from parallel-connected modules, the battery, or the inverter.

Because the conductors and overcurrent devices are sized to deal with 156% of the short-circuit current for that particular PV circuit, overcurrents from those modules or PV sources, which are limited to the short-circuit current (or at worst,

125% of the short-circuit current), cannot trip the overcurrent device in this circuit. The overcurrent devices in these circuits protect the conductors from overcurrent from parallel-connected sets of modules or overcurrent from the battery bank. In stand-alone systems or utility-interactive systems, these array overcurrent devices protect the array wiring from overcurrent from parallel strings of modules, the battery, or from the generator or ac utility power.

Often, PV modules or series strings of modules are connected in parallel. As the conductor size used in the array wiring increases to accommodate the higher short-circuit currents of paralleled modules, each conductor size is protected by an appropriately sized overcurrent device. These overcurrent devices **must** be placed nearest all sources of potential overcurrent for that conductor [240.1]. Figure 14 shows an example of array conductor overcurrent protection for a medium-size array broken into subarrays. The cable sizes and types shown are examples only. The actual sizes will depend on the ampacity needed.

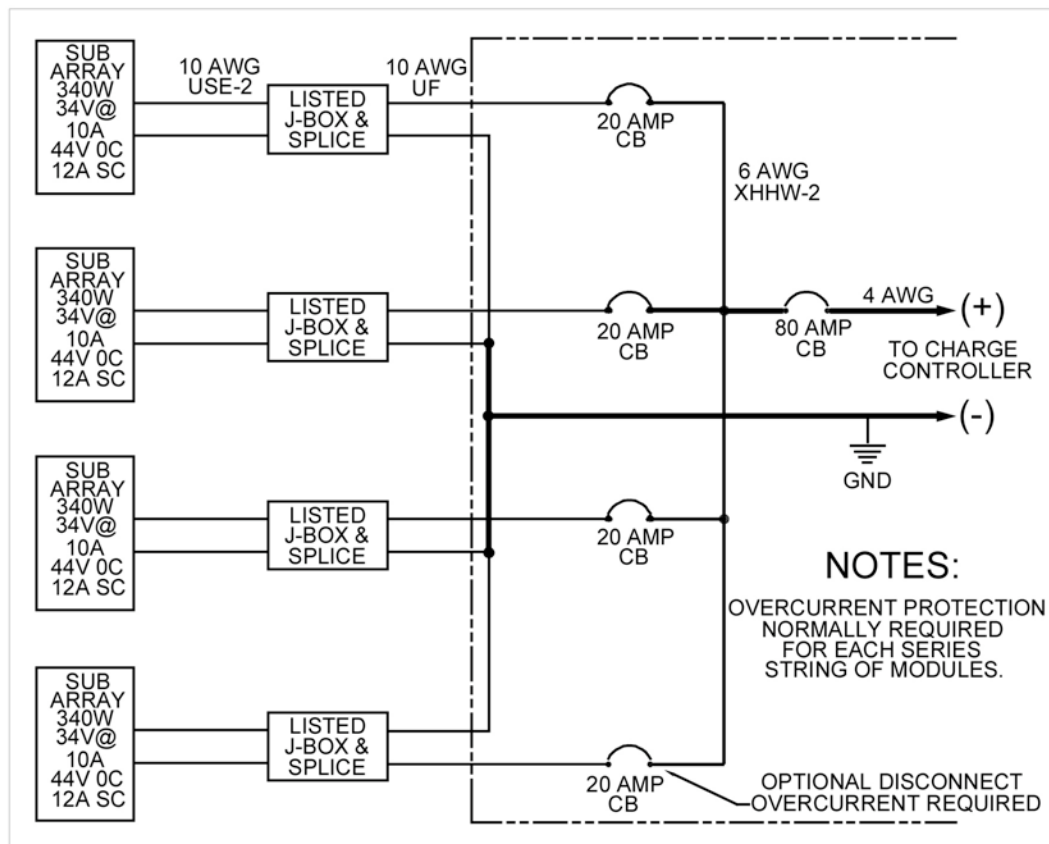

Figure 14. Typical Array Conductor Overcurrent Protection (with Optional Subarray Disconnects)

Either fuses or circuit breakers are acceptable for overcurrent devices provided they are rated for their intended uses—i.e., they have dc ratings when used in dc circuits, the ampacity is correct, and they can interrupt the necessary currents when short circuits occur [240]. Figure 15 shows typical branch-circuit-rated, dc-rated, listed circuit breakers. The *NEC* allows the use of less-robust listed

supplementary-type overcurrent devices only for PV source circuit protection [690.9(C)]. See Figures 16 and 17.

Some overcurrent devices rated at less than 100 amps may have terminals that are rated for use with 60°C conductors unless marked for use with 75°C conductors. The ampacity calculations of the connected cables may have to be adjusted. See Appendix I for the details of how the ratings of overcurrent devices are calculated.

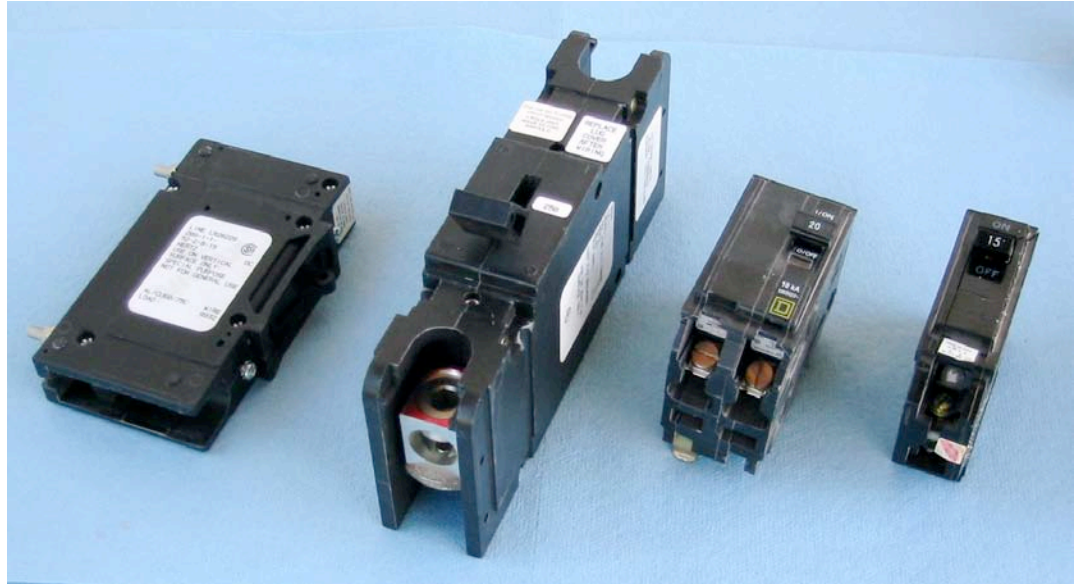

Figure 15. Listed Branch-Circuit Rated Breakers-Three on left are DC rated

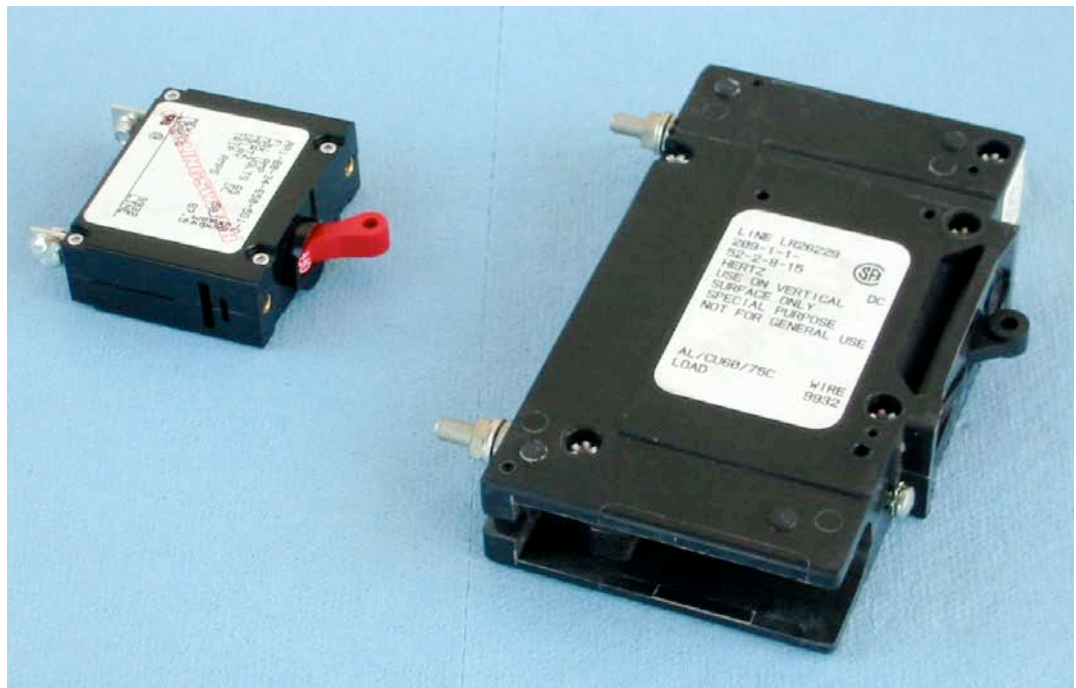

Figure 16. Recognized (left) and listed (right) DC Circuit Breakers

BRANCH CIRCUITS

DC branch circuits in stand-alone systems start at the battery and go to the receptacles supplying the dc loads or to the dc loads that are hard wired, such as inverters. In direct-connected systems (no battery), the PV output circuits go to the power controller or master dc power switch and a branch circuit goes from this location to the load. In utility-intertie systems, the circuit between the inverter and the ac-load center may be considered a feeder or possibly a branch circuit.

Fuses used to protect dc or ac branch (load) and feeder circuits **must** be listed for that use. They **must** also be of different sizes and markings for each amperage and voltage group to prevent unintentional interchange [240 VI]. These particular requirements eliminate the use of glass fuses and plastic automotive fuses as branch-circuit overcurrent devices because they are neither tested nor rated for this application. DC-rated fuses that meet the requirements of the *NEC* are becoming more available. Figure 17 shows *listed*, dc-rated, time-delay fuses on the right that are acceptable for branch circuit use, which would include the battery fuse. The cut-away fuse shows the complexity of the mechanisms required to interrupt dc currents. Acceptable dc-rated, *listed* fast-acting *supplementary* fuses are shown on the left and can be used in the PV source circuits. The fuses shown are made by Littelfuse (Appendix A) and Bussmann. Ferraz and others also have listed dc ratings on the types of fuses that are needed in PV systems.



Figure 17. Listed Supplementary (two on left) and Branch Circuit (right) Fuses

Automotive fuses have no dc rating by the fuse industry or the testing laboratories and **should not be used in PV systems**. When rated by the manufacturer, they have only a 32-volt maximum rating, which is less than the open-circuit voltage from a 24-volt PV array. Furthermore, these fuses have no rating for interrupt current, nor are they generally marked with all of the information required for branch-circuit fuses. They are not considered supplementary fuses under the UL listing or component recognition programs. Figure 18 shows unacceptable automotive fuses on the left and unacceptable (for dc applications) ac fuses on the right. Unfortunately, even the listed ac fuses are intended for ac use and frequently have no dc ratings.

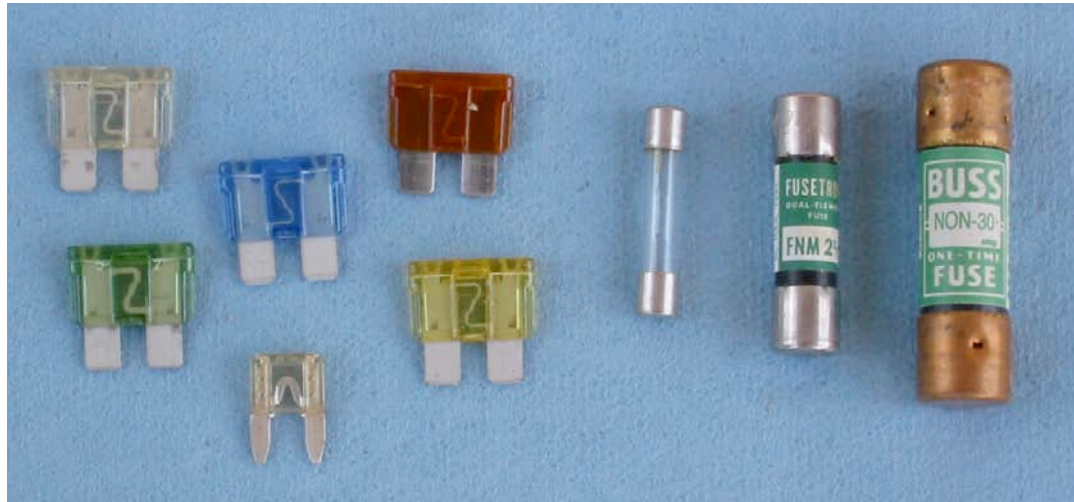

Figure 18. Unlisted, Unacceptable Automotive Fuses (left) and Listed, Unacceptable AC Fuses (right)

Circuit breakers also have specific requirements when used in branch circuits, but they are generally available with the needed dc ratings [240 VII].

To provide maximum protection and performance (lowest voltage drop) on branch circuits (particularly on 12 and 24-volt systems), the ampacity of the conductors might be increased, but the rating of the overcurrent devices protecting that cable should be as low as possible consistent with load currents. A general formula for cable ampacity and overcurrent device rating is 100% of the noncontinuous loads and 125% of the continuous loads anticipated [215.2]. Normally only worst-case continuous currents are used for ampacity and overcurrent calculations in PV systems. See Appendix I for the details of selecting appropriate overcurrent devices.

AMPERES INTERRUPTING RATING (AIR)—SHORT-CIRCUIT CONDITIONS

Overcurrent devices—both fuses and circuit breakers—are required to be able to safely open circuits with short-circuit currents flowing in them. Since PV arrays are inherently current limited, high short-circuit currents from the PV array are normally not a problem when the conductors are sized as outlined above. In stand-

alone systems with storage batteries, however, the short-circuit condition is very severe. A single 220 amp-hour, 6-volt, deep-discharge, lead-acid battery may produce short-circuit currents as high as 8,000 amps for a fraction of a second and as much as 6,000 amps for a few seconds in a direct terminal-to-terminal short circuit. Such high currents can generate high temperatures and magnetic forces that can cause an underrated overcurrent device to burn or blow apart. Two paralleled batteries could generate nearly twice as much current, and larger capacity batteries would be able to deliver proportionately more current under a short-circuit condition. In dc systems, particularly stand-alone systems with batteries, the interrupt capability of every overcurrent device is important. This interrupt capability or interrupt rating is specified as Amperes Interrupting Rating (AIR) and sometimes Amperes Interrupting Capability (AIC).

Some dc-rated, listed, branch circuit breakers that can be used in PV systems have an interrupt rating of 5,000 amps at 48 volts dc. However, Heinemann and AirPax make numerous circuit breakers with interrupt ratings of 25,000 amps at voltages from 65 to 125 volts (Appendix A). Some dc-rated, listed supplementary circuit breakers have an AIR of only 3,000 amps. Many listed, dc-rated class-type fuses have an AIR of up to 20,000 amps.

Fuses or circuit breakers **shall never be** paralleled or ganged to increase current-carrying capability unless done so by the manufacturer and listed for such use [240.8].

Since PV systems may have transients—lightning and motor starting as well as others—inverse-time circuit breakers (the standard type) or time-delay fuses should be used in most cases. In circuits where no transients are anticipated, fast-acting fuses can be used. They should be used if relays and other switchgear in dc systems are to be protected. Time-delay fuses that can also respond very quickly to short-circuit currents may also be used for system protection.

FUSING OF PV SOURCE CIRCUITS

The *NEC* allows supplementary overcurrent devices (fuses and circuit breakers) to be used in PV source circuits [690.9(C)]. (See Figure 17.) A supplementary overcurrent device is one that is designed for use inside a piece of listed equipment. These devices supplement the main branch-circuit overcurrent device and do not have to comply with all of the requirements of fully rated branch overcurrent devices. They **shall**, however, be dc rated, listed, and able to handle the short-circuit currents they may be subjected to [690.9(D)]. Unfortunately, many supplementary fuses are not dc rated, and if they are, the interrupt rating (when available) is usually less than 5,000 amps. A mitigating factor is that the location of supplementary fuses in PV source circuits and PV output circuits places them at some electrical distance from potentially high short-circuit currents from the battery. At this location, the available short-circuit currents may be within their interrupt rating. The use of ac-only-rated supplementary fuses **is not** allowed for the dc circuits of PV systems [110.3(B)].

CURRENT-LIMITING FUSES—STAND-ALONE SYSTEMS

A current-limiting fuse **must** be used in each ungrounded conductor from the battery where the down-stream overcurrent devices or switchgear have interrupt ratings less than the available short-circuit currents [690.71(C), 240.2, 110.9]. This fuse will limit the current that a battery bank can supply to a short circuit and should reduce the short-circuit currents to levels that are within the capabilities of downstream equipment [690.71(C)]. These fuses are available with dc ratings of 125, 300, and 600 volts dc, currents of 0.1 to 600 amps, and a dc interrupt of 20,000 amps. They are classified as RK5 or RK1 current-limiting fuses and should be mounted in Class-R rejecting fuse holders or dc-rated, fused disconnects. Class J or T fuses with dc ratings might also be used. For reasons mentioned previously, time-delay fuses should be specified, although some designers are getting good results with Class T fast-acting fuses.

One of these fuses and the associated disconnect switch should be used in **each** bank of batteries with a paralleled amp-hour capacity up to 1,000 amp-hours. Many 12, 24 and 48-volt battery banks are connected without overcurrent devices in each string of batteries and these have proved durable over the years. However, as batteries age and load conditions change, string current becomes unbalanced and the fuse in each string may help to prevent total battery bank failures under normal and fault conditions. On battery systems with higher than 48 volts nominal rating, the use of a disconnect and overcurrent device in each string of cells is necessary to prevent system failures that could result in fires and explosions and to allow for proper servicing [690.71].

Batteries with single-cell amp-hour capacities higher than 1,000 amp-hours will require special design considerations, because these batteries may be able to generate short-circuit currents in excess of the 20,000 AIR rating of the current-limiting fuses. When calculating the available short-circuit currents at a particular point in the circuit, the resistances of all connections, terminals, wire, fuse holders, circuit breakers, and switches to that point need to be considered. These resistances serve to reduce the magnitude of the available short-circuit currents at any particular point. The suggestion of one fuse per 1,000 amp-hours of battery size is only a general estimate, and the calculations are site specific. The listed branch-circuit fuses shown in Figure 17 are current limiting.

In lieu of current-limiting fuses, circuit breakers with high interrupt ratings may be used throughout the system for all overcurrent devices. These circuit breakers are not current limiting, even with the high interrupt rating, so they cannot be used to protect other types of fuses or circuit breakers. An appropriate use would be in the conductor between the battery bank and the inverter. This single device would minimize voltage drop and provide the necessary disconnect and overcurrent features. When high interrupt rating circuit breakers are used throughout a PV system, there is *NO* requirement for a current-limiting fuse, since each circuit breaker is capable of interrupting the short-circuit currents that may be impressed upon it.

CURRENT-LIMITING FUSES—UTILITY-INTERACTIVE SYSTEMS

Normal electrical installation practice requires that utility service entrance equipment have fault-current protection devices that can interrupt the available short-circuit currents [110.9]. This requirement applies to the utility side of any power conditioning system in a PV installation. If the service is capable of delivering fault currents in excess of the interrupt rating of the overcurrent devices used to connect the inverter to the system, then current-limiting overcurrent devices **must** be used [110.9]. In utility-interactive systems that are connected to the line side of the service disconnect, particular attention should be paid to the amount of available short-circuit current from the utility feeder.

However, many utility-interactive PV systems make the utility connection through a back-fed circuit breaker in an existing load center and the existing load center is designed to handle the available short-circuit currents. No additional current limiting is required. If a new service entrance is added for the output of the PV system, then the service entrance equipment **must** have the appropriate ratings [690.64]. See Appendix C for additional details.

FUSE SERVICING

Whenever a fuse is used as an overcurrent device and is accessible to unqualified persons, it **must** be installed in such a manner that all power can be removed from both ends of the fuse for servicing. It is not sufficient to reduce the current to zero before changing the fuse. There **must** be no voltage present on either end of the fuse prior to service. This may require the addition of switches on both sides of the fuse location—a complication that increases the voltage drop and reduces the reliability of the system [690.16]. Because of this requirement, the use of a fusible pullout-style disconnect, “finger-safe” fuse holder, or circuit breaker is recommended.

Optionally ungrounded 12-volt and some 24-volt PV systems require an overcurrent device in both of the ungrounded conductors of each circuit. Since an equipment-grounding system is required on all systems, grounding the system and using overcurrent devices only in the remaining ungrounded conductors may reduce costs.

DISCONNECTING MEANS

There are many considerations in configuring the disconnect switches for a PV system. The *National Electrical Code* deals with safety first and other requirements last—if at all. The PV designer should also consider equipment damage from over voltage, performance options, equipment limitations, and cost.

A photovoltaic system is a power generation system, and a specific minimum number of disconnects are necessary to deal with that power. Untrained personnel will be operating the

systems; therefore, the disconnect system **must** be designed to provide safe, reliable, and understandable operation [690 III].

Disconnects may range from nonexistent in a self-contained PV-powered light for a sidewalk to those found in the space-shuttle-like control room in a large, multi-megawatt, utility-tied PV power station. Generally, local inspectors will not require disconnects on totally enclosed, self-contained PV systems like a PV-powered, solar, hot-water circulating system. This would be particularly true if the entire assembly were listed as a unit and there were no external contacts or user serviceable parts. However, the situation changes as the complexity of the device increases and separate modules, inverters, batteries, and charge controllers having external connections are wired together and possibly operated and serviced by unqualified personnel.

PHOTOVOLTAIC ARRAY DISCONNECTS

Article 690 requires all current-carrying conductors from the PV power source or other power source to have *disconnect* provisions. This provision includes the grounded conductor, if any [690 III]. *Ungrounded* conductors **must** have a switch or circuit breaker disconnect [690.13, 15, 17]. *Grounded* conductors which normally remain connected at all times, may have a bolted disconnect (terminal or lug) that can be used for service operations and for meeting the *NEC* requirements. Disconnect switches **must not** open grounded conductors [690.13]. Grounded conductors of faulted source circuits in roof-mounted dc PV arrays on dwellings are allowed to be automatically interrupted as part of ground-fault protection requirements in 690.5. [690.13]

In an ungrounded 12-volt PV system (as allowed by [690.41]), both positive and negative conductors **must** be switched, since both are ungrounded. Since all systems **must** have an equipment-grounding system, costs may be reduced and performance improved by grounding 12-volt systems and using one-pole disconnects on the remaining ungrounded conductor.

Ungrounded systems operating at higher voltages, as will be allowed by the 2005 *NEC* in 690.35, will also require switched disconnects and overcurrent protection in all of the circuit conductors since both the positive and negative circuit conductors will be ungrounded. See Appendix L for additional discussions of ungrounded PV systems.

PV DISCONNECT LOCATION

Let us first consider the ac utility service to the typical residence. Either an overhead or an underground feeder will deliver the power. Before this service feeder gets into the house, it usually first goes through a billing kilowatt-hour meter and then the service entrance disconnect. In many jurisdictions, the local code allows the main disconnect to be immediately inside the home at the point of first penetration by the conductors of the building as allowed by the *National Electrical Code (NEC)* See *NEC* Section 230. In other locations, and the number is increasing, the service entrance disconnect **must** be located on the outside of the house with the load center sans disconnect inside the house [local codes]. In

all cases this disconnect **must** be “readily accessible,” which means it **must** not be in locked compartments, no ladders are required to access it, and no building material **must** be removed to get to it [690.14, 100-readily accessible]. These requirements were established many years ago to allow fire response personnel to quickly and safely shut off power to a building on fire that might require the firefighters to enter and cut holes in walls, ceilings and roofs. In life threatening situations, time is of the essence.

The *NEC* in Section 690.14 requires that the main PV disconnect be in a similar location. It therefore **must** be in a readily accessible location (no bathrooms, no attics—unless served by a permanent fixed stairs) at the point of first penetration of the dc PV source or output conductors. As in the ac service entrance disconnect, this PV disconnect may be located immediately inside the point of first penetration of the conductors. If the attic is reached by fixed stairs (not pull down), then the disconnect might be mounted in that location. Disconnects in bathrooms are not allowed. Other readily accessible rooms are acceptable as long as there are no locked doors.

Although commonly done in the past, many inspectors are not allowing PV conductors from the roof-mounted PV array to penetrate the attic and be run through the walls to the first floor or the basement where the main PV disconnect is located. These “always energized” conductors pose hazards to fire response personnel and possibly a fire hazard since they are in locations where potential short circuits might start fires.

The *2005 NEC* allows an inside circuit installation provided it meets certain additional requirements. If the conductors are installed in a metal conduit or raceway, they will be permitted (not required) to be routed inside the house to the dc disconnect located at some distance from the point of first penetration. The disconnect will still have to be readily accessible, but this allowance, if adopted, will permit more design and installation flexibility. The metal conduit/raceway provides for added fire protection (does not burn), mechanical protection (difficult to accidentally cut), and ground-fault detection (in the event there is an internal ground fault). [690.31(E)]

EQUIPMENT DISCONNECTS

Each piece of equipment in the PV system **shall** have disconnect switches to disconnect it from all sources of power. The disconnects **shall** be circuit breakers or switches and **shall** comply with all of the provisions of Section 690.17. DC-rated switches are expensive; therefore, the ready availability of moderately priced dc-rated circuit breakers with ratings up to 125 volts and 110 amps would seem to encourage their use in all 12-, 24-, and 48-volt systems. When properly located and used within their approved ratings, circuit breakers can serve as both the disconnect and overcurrent device. In simple stand-alone systems, one switch or circuit breaker disconnecting the PV array and another disconnecting the battery may be all that is required.

In larger utility-interactive systems, there may be several string disconnect switches, sub array disconnects, main PV disconnects for each inverter, ac output disconnects for each inverter and a complete system ac disconnect (sometimes operating at 12 kV).

A 2,000-watt inverter on a 12-volt system can draw more than 235 amps at full load. A 250kW utility-interactive inverter may have a PV dc input disconnect that carries 800 amps at 300 volts or more. Disconnect switches **must** be rated to carry the current and have appropriate voltage and interrupt ratings [110.3(B)]. Again, a dc-rated, listed circuit breaker may prove less costly and more compact than a switch and fuse with the same ratings; at least in systems operating up to a nominal voltage of 48 volts.

BATTERY DISCONNECT

When the battery is disconnected from the stand-alone system, either manually or through the action of a fuse or circuit breaker, care should be taken that the PV system not be allowed to remain connected to the load. Depending on the design of the charge controller, small loads may allow the PV array voltage to increase from the normal battery charging levels to the open-circuit voltage, which will shorten dc lamp life and possibly damage electronic components.

This potential problem can be alleviated somewhat by using ganged multi-pole circuit breakers or ganged fused disconnects as shown in Figure 20. This figure shows two ways of making the connection. Of course, fuses in a ganged unit may operate independently, which may still create a problem. Separate circuits, including disconnects and fuses between the charge controller and the battery and the battery and the load, as shown in Figure 19, may be used if it is desired to operate the loads without the PV array being connected. If the design requires that the entire system be shut down with a minimum number of switch actions, the switches and circuit breakers could be ganged multi-pole units.

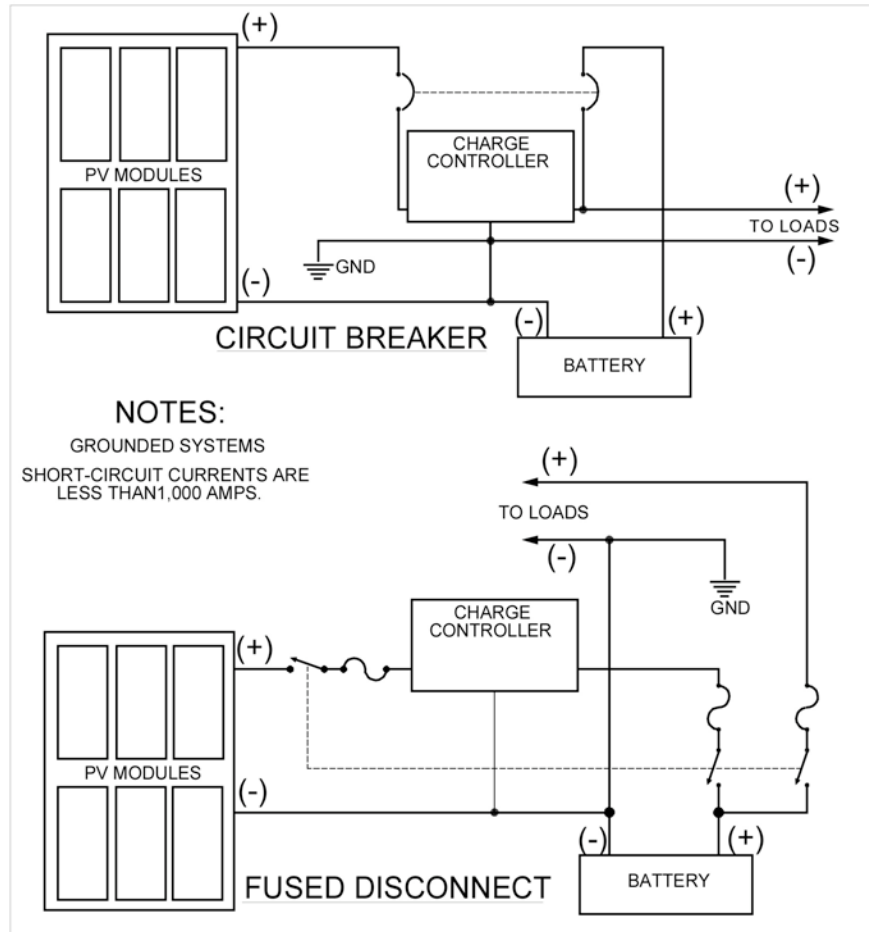

Figure 19. Small System Disconnects

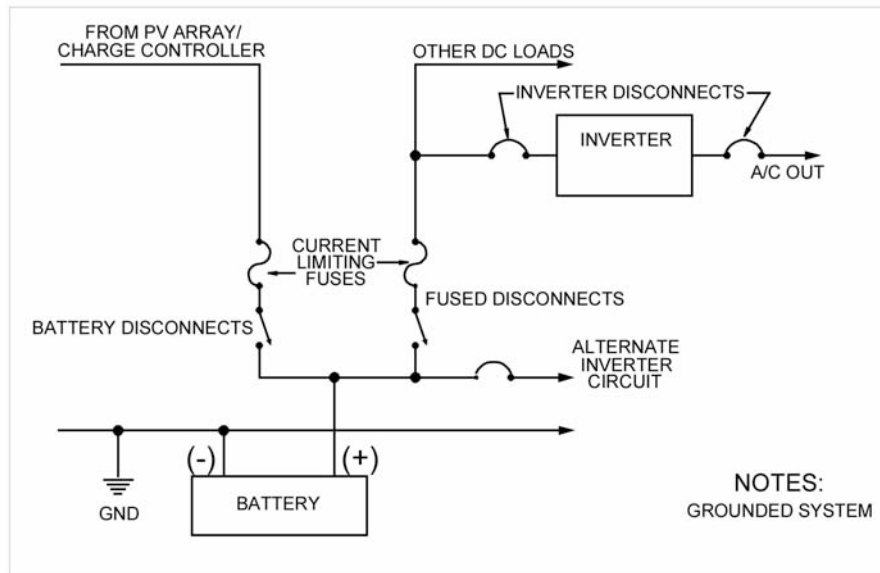

Figure 20. Separate Battery Disconnects

CHARGE CONTROLLER DISCONNECTS

Some unlisted charge controllers are fussy about the sequence in which they are connected and disconnected from the system. These charge controllers do not respond well to being connected to the PV array and not being connected to the battery. The sensed battery voltage (or lack thereof) would tend to rapidly cycle between the array open-circuit voltage and zero as the controller tried to regulate the nonexistent charge process. This problem will be particularly acute in self-contained charge controllers with no external battery sensing. The use of charge controllers listed to *UL Standard 1741* will minimize this problem. In this case, such a listed charge controller has been designed to operate properly with all of the overcurrent protection and disconnects required by the *NEC*.

Again, the multi-pole switch or circuit breaker can be used to disconnect not only the battery from the charge controller, but the charge controller from the array. Probably the safest method for self-contained charge controllers is to have the PV disconnect switch disconnect both the input and the output of the charge controller from the system. Larger systems with separate charge control electronics and switching elements will require a case-by-case analysis—at least until the controller manufacturers standardize their products. Figure 21 shows two methods of disconnecting the charge controller.

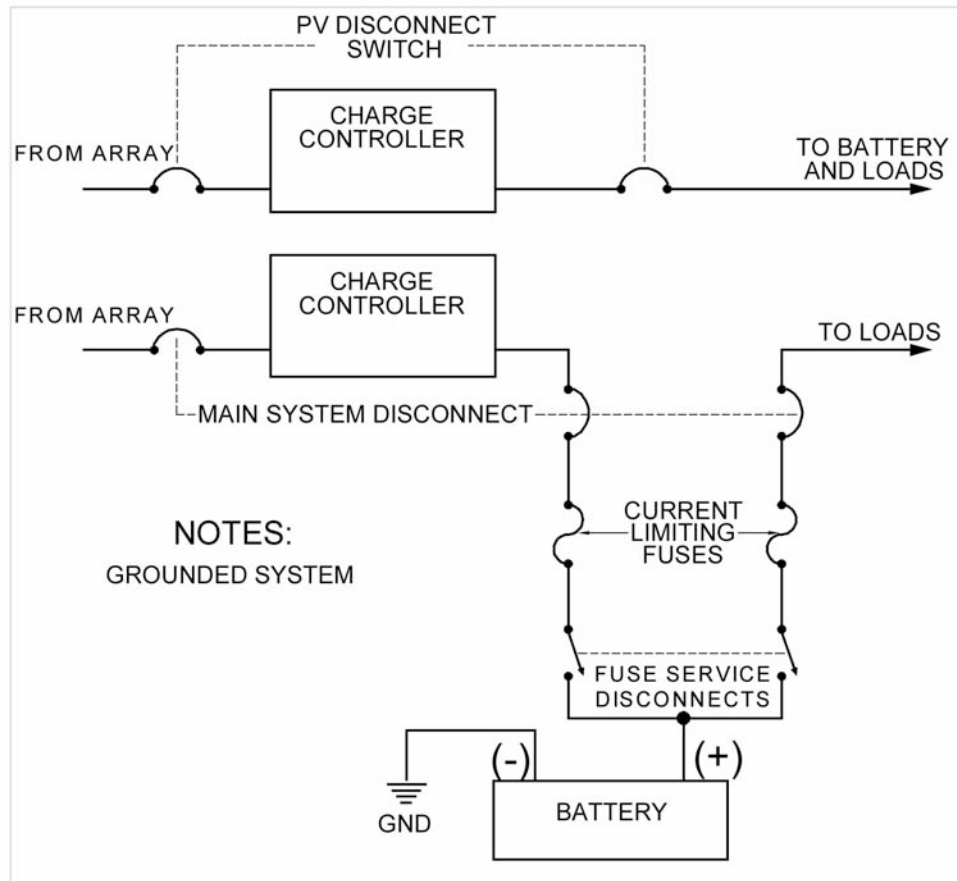

Figure 21. Charge Controller Disconnects

UNGROUNDING SYSTEMS

Systems that do not have one of the current-carrying conductors grounded **must** have disconnects *and* overcurrent devices in all of the ungrounded conductors [240.20, 690.13]. This means two-pole devices for the PV, battery, and inverter disconnects and overcurrent devices. The additional cost is considerable. See Appendix L for more information.

MULTIPLE POWER SOURCES

When multiple sources of power are involved, the disconnect switches **shall** be grouped and identified [230.72, 690.14(C)(5)]. No more than six motions of the hand will be required to operate all of the disconnect switches required to remove all power from the system [230.71]. These power sources include PV output, the battery system, any generator, and any other source of power. Multi-pole disconnects or handle ties should be used to keep the number of motions of the hand to six or fewer.

Article 230 in the NEC allows each structure to have more than one source of supply. The sources might be a utility connection and a PV system. The disconnects of these two sources of supply do not have to be grouped [230.2, 230.71]. However placards are required showing where all of the disconnects are located [230.70, 690.54, 705.10].

PANELBOARDS, ENCLOSURES, AND BOXES

Disconnect and overcurrent devices **shall** be mounted in listed enclosures, panelboards, or boxes [240 III]. Wiring between these enclosures **must** use a *NEC*-approved method [110.8]. Appropriate cable clamps, strain-relief methods, or conduit **shall** be used. All openings not used **shall** be closed with the same or similar material to that of the enclosure [110.12(A)]. Metal enclosures **must** be bonded to the equipment-grounding conductor [250.110, 408.40]. The use of wood or other combustible materials is discouraged. Conductors from *different* systems such as utility power, gas generator, hydro, or wind **shall not** be placed in the same enclosure, box, conduit, etc., as PV source conductors unless the enclosure is partitioned [690.4(B)]. This requirement stems from the need to keep "always live" PV source conductors separate from those that can be turned off. The ac outputs of a specific PV system may be routed in the same conduit or raceway as the dc PV source conductors from the *same* system providing that all conductors meet the insulation requirements of 300.3(C)(1).

When designing a PV distribution system or panel board, a listed NEMA type box and listed disconnect devices and overcurrent devices should be used. The requirements for the internal configuration of these devices are established by *NEC* Articles 110, 408, portions of article 690 as well as other articles in the code and **must** be followed. Dead front-panelboards with no exposed current-carrying conductors, terminals, or contacts are generally required [408.38]. Underwriters Laboratories also establishes the standards for the internal construction of panelboards and enclosures. The use of a listed commercial product designed for use in PV systems is encouraged

BATTERIES

In general, *NEC* Articles 480 and 690 VIII should be followed for installations having storage batteries. Battery storage in PV systems poses several safety hazards:

- Hydrogen gas generation from charging batteries
- High short-circuit current
- Acid or caustic electrolyte
- Electric shock potential

HYDROGEN GAS

When flooded, non-sealed, lead-acid batteries are charged at high rates, or when the terminal voltage reaches 2.3 - 2.4 volts per cell, the batteries produce hydrogen gas. Even sealed batteries may vent hydrogen gas under certain conditions. This gas, if confined and not properly vented, poses an explosive hazard. The amount of gas generated is a function of the battery temperature, the voltage, the charging current, and the battery-bank size. Hydrogen is a light, small-molecule gas that is easily dissipated and is very difficult to contain. Small battery banks (i.e., up to 20, 220-amp-hour, 6-volt batteries) placed in a large room or a well-ventilated (drafty) area may not pose a significant hazard. Larger numbers of batteries in smaller or tightly enclosed areas require venting. Venting manifolds attached to each cell and routed to an exterior location are not recommended because flames in one section of the manifold may be easily transmitted to other areas in the system. The instructions provided by the battery manufacturer should be followed.

Closed battery boxes with single vents to outside-the-house air may pose problems unless carefully designed. Wind may force hydrogen back down the vent.

A catalytic recombiner cap (Hydrocap® Appendix A) may be attached to each cell of a flooded, lead-acid battery to recombine some of the evolved hydrogen and oxygen to produce water. If these combiner caps are used, they will require occasional maintenance. It is rarely necessary to use power venting. Flame arrestors are required by *NEC* Section 480.9, and battery manufacturers can provide special vent caps with flame-arresting properties when the local authority requires them.

Certain charge controllers are designed to minimize the generation of hydrogen gas, but lead-acid batteries need some overcharging to fully charge the cells. This produces gassing that should be dissipated.

In *no case* should charge controllers, switches, relays, or other devices capable of producing an electric spark be mounted in a battery enclosure or directly over a battery bank. Care needs to be exercised when routing conduit from a sealed battery box to a disconnect. Hydrogen gas may travel in the conduit to the arcing contacts of the switch. It is suggested that any conduit openings in battery boxes

be made below the tops of the batteries, since hydrogen rises to the top of the enclosure as it displaces the air.

BATTERY ROOMS AND CONTAINERS

Battery systems are capable of generating thousands of amps of current when shorted. A short circuit in a conductor not protected by overcurrent devices can melt wrenches or other tools, battery terminals and cables, and spray molten metal around the room. Exposed battery terminals and cable connections **must** be protected. Live parts of batteries **must** be guarded [690.71]. This generally means that the batteries should be accessible only to a qualified person. A locked room, battery box, or other container and some method to prevent access by the untrained person should reduce the hazards from short circuits and electric shock. The danger may be reduced if insulating caps or tape are placed on each terminal and an insulated wrench is used for servicing. Note that with protective caps, corrosion may go unnoticed on the terminals. The *NEC* requires certain spacing around battery enclosures and boxes and other equipment to allow for unrestricted servicing—generally about three feet [110.26]. Batteries should not be installed in living areas, nor should they be installed below any enclosures, panelboards, or load centers [110.26].

One of the more suitable, readily available battery containers is the lockable, heavy-duty black polyethylene toolbox. Such a box can hold up to four L-16 size batteries and is easily cut for ventilation holes in the lid and for conduit entrances.

NEC Section 690.71(D) prohibits the use of conductive cases for flooded, lead-acid batteries operating above 48-volts nominal. Racks for these batteries may have no conductive parts within than 6" (150 mm) of the tops of the cases. These requirements were established to minimize the probability of high-voltage ground faults developing in the dust and electrolyte film that develops on these vented batteries during normal operation.

ACID OR CAUSTIC ELECTROLYTE

A thin film of electrolyte can accumulate on the tops of the battery and on nearby surfaces. This material can cause flesh burns. It is also a conductor and, in high-voltage battery banks, poses a shock hazard, as well as a potential ground-fault path. The film of electrolyte should be removed periodically with an appropriate neutralizing solution. For lead-acid batteries, a dilute solution of baking soda and water works well. Commercial neutralizers are available at auto-supply stores.

Charge controllers are available that minimize the dispersion of the electrolyte and water usage because they minimize battery gassing. They do this by keeping the battery voltage from climbing into the *vigorous* gassing region where the high volume of gas causes electrolyte to mist out of the cells. A moderate amount of gassing is necessary for proper battery charging and de-stratification of the electrolyte in flooded cells.

Battery servicing hazards can be minimized by using protective clothing including facemasks, gloves, and rubber aprons. Self-contained eyewash stations and neutralizing solution are good precautionary additions to any battery room. Water should be used to wash acid or alkaline electrolyte from the skin and eyes.

Anti-corrosion sprays and greases are available from automotive and battery supply stores and they generally reduce the need to service the battery bank. Hydrocap® Vents also reduce the need for servicing by reducing the need for watering.

ELECTRIC SHOCK POTENTIAL

Storage batteries in dwellings **must** operate at less than 50 volts (48-volt nominal battery bank) unless live parts are protected during routine servicing [690.71(B)(1)]. It is recommended that live parts of any battery bank should be guarded [690.71(B)(2)].

BATTERY AND OTHER LARGE CABLES

Battery cables, even though they can be 2/0 AWG and larger, **must** be a standard building-wire type conductor [Chapter 3]. Welding and automobile “battery” cables (listed and non-listed) are not allowed. Flexible, highly-stranded, building-wire type cables (USE/RHW and THW) are available for this use. Flexible cables, identified in Section 400 of the *NEC* are permitted (not required) from the battery terminals to a nearby junction box and between battery cells. These cables shall be listed for hard service use and moisture resistance [690.74]. As is the case with flexible PV module interconnecting cables, it is rarely necessary to use anything other than the normal building wire types of cables identified in Chapter 3 of the *NEC*. Also the types of terminals that can be used with these flexible cables are limited. In general, the manufacturer’s data should be consulted or the terminal or lug should be marked indicating compatibility with the fine stranded cables. The few lugs that are compatible are made of solid copper, have a flared entry section and look somewhat like the three lugs on the far right in Figure 5.

GENERATORS

Other electrical power generators such as wind, hydro, and gasoline/propane/diesel **must** comply with the requirements of the *NEC*. These requirements are specified in the following *NEC* articles:

Article 230	Services
Article 250	Grounding
Article 445	Generators
Article 700	Emergency Systems
Article 701	Legally Required Standby Systems
Article 702	Optional Standby Systems
Article 705	Interconnected Power Production Sources

When multiple sources of ac power are to be connected to the PV system, they **must** be connected with an appropriately rated and listed transfer switch [702.6]. AC generators frequently are rated to supply larger amounts of power than that supplied by the PV/battery/inverter. The transfer switches (external to the inverter or a relay built into listed inverters) **must** be able to safely accommodate either power source [110.3(B)].

Grounding, both equipment and system, needs to be carefully considered when a generator is connected to an existing system. There **must** be no currents flowing in the equipment-grounding conductor under any normal operating mode of the system [250.6]. Bonds (connections) between the ac grounded conductor (neutral) and the grounded frame in generators are common and have caused circulating, unwanted currents.

The circuit breakers or fuses that are built into the generator are usually not sufficient to provide *NEC*-required protection for the conductors from the generator to the PV system. An external (branch circuit rated) overcurrent device (and possibly a disconnect) **must** be mounted close to the generator [240.21]. The conductors from the generator to this overcurrent device **must** have an ampacity of not less than 115% of the nameplate current rating of the generator [445.12]. Figure 22 shows a typical one-line diagram for a system with an auxiliary backup generator.

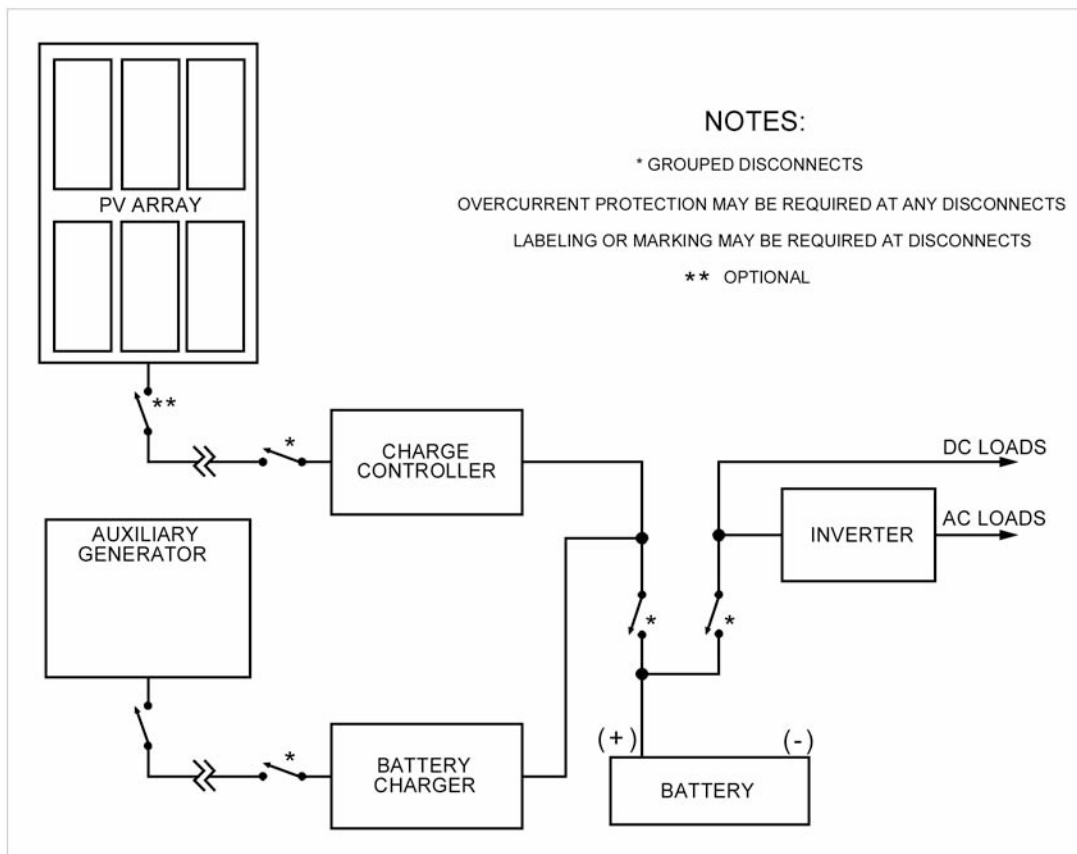

Figure 22. Disconnects for Remotely Located Power Sources. Disconnects for Remotely Located Power Sources

CHARGE CONTROLLERS

A charge controller or self-regulating system **shall** be used in a stand-alone system with battery storage. The mechanism for adjusting state of charge **shall** be accessible only to qualified persons [690.72].

There are several charge controllers on the market that have been tested and listed to UL standards by recognized testing organizations.

Surface mounting of unlisted charge controllers with external terminals readily accessible to the unqualified person will not be accepted by the inspection authority. Dead-front panels with no exposed contacts are generally required for safety. Figure 23 shows a typical charge controller and remote display panel. It is a listed device, has no exposed terminals, is ready for installation with conduit, and has no readily-accessible user adjustments.

Electrically, listed charge controllers are designed with a “straight” conductor between the negative input and output terminals. A shunt is sometimes placed in that conductor. This design will allow the controller to be used in a grounded system with the grounded conductor running through the controller. The installation manual of the charge controller **must** be reviewed to ensure proper system grounding [110.3(B)].

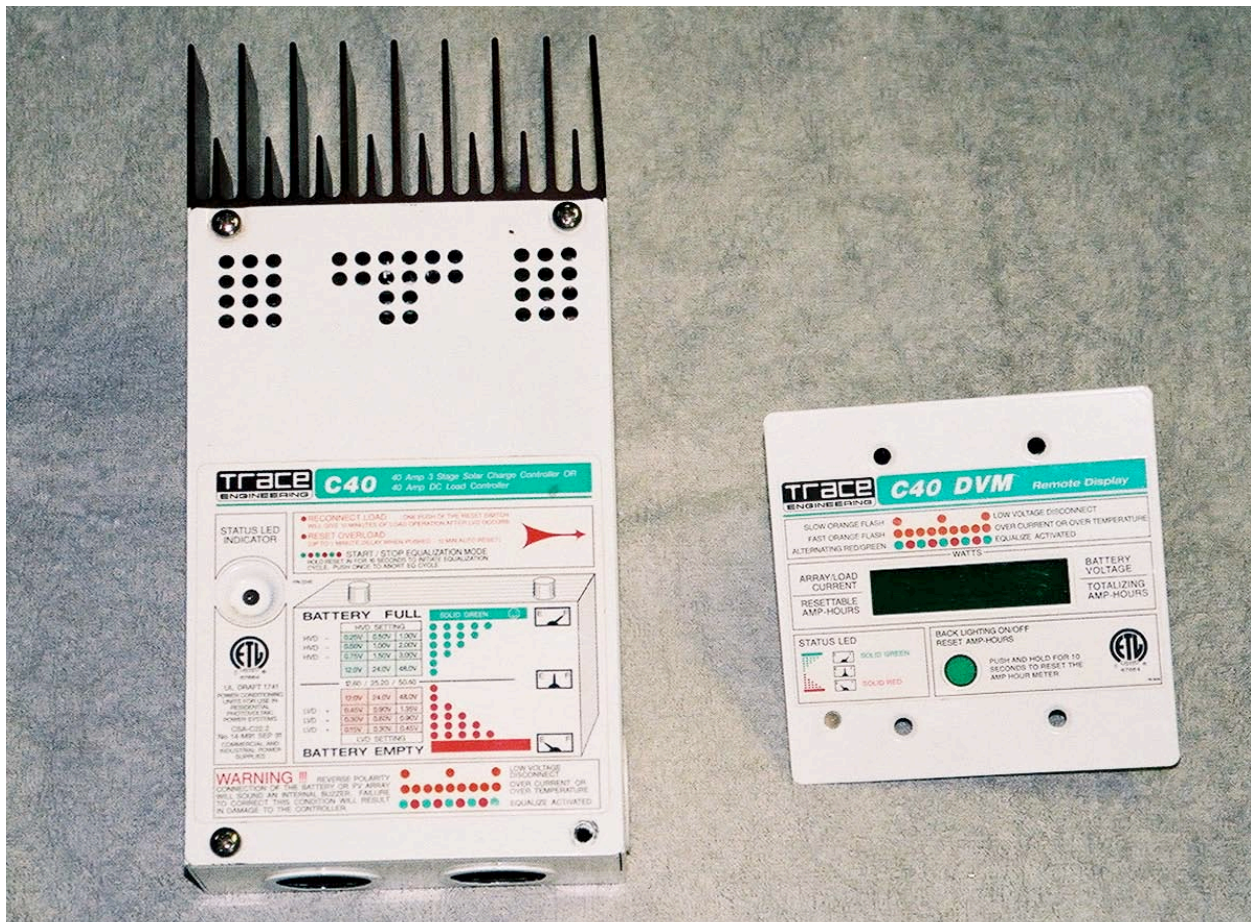

Figure 23. Typical Charge Controller

INVERTERS

Inverters can have stand-alone, utility-interactive, or combined capabilities.

The ac output wiring is not significantly different from the ac wiring in residential and commercial construction, and the same general requirements of the Code apply. In the case of utility-interactive systems and combined systems, ac power may flow through circuits in both directions. This two-way current flow will normally require overcurrent devices at both ends of the circuit.

The dc input wiring associated with stand-alone or hybrid inverters is the same as the wiring described for batteries. Most of the same rules apply; however, the calculation of the dc input current needs special consideration since the *NEC* does not take into consideration some of the finer points required to achieve the utmost in reliability. Appendix F discusses these special requirements in greater detail.

The dc input wiring associated with utility-interactive inverters is similar, in most cases, to the wiring in PV source and output circuits.

Inverters with combined capabilities will have both types of dc wiring: connections to the batteries and connections to the PV modules.

STAND-ALONE DISTRIBUTION SYSTEMS

The *National Electrical Code* has evolved to accommodate supplies of relatively cheap energy. As the Code was expanded to include other power systems such as PV, many sections were not modified to reflect the recent push toward more efficient use of electricity in the home. Stand-alone PV systems *may* be required to have dc services with 60- to 100-amp capacities to meet the Code [230.79]. DC receptacles for appliances and lighting circuits, where used, *may* have to be as numerous as their ac counterparts [220, 422]. In a small one- to four-module system on a remote cabin where no utility extensions or local grids are possible, these requirements may be excessive, since the power source may be able to supply only a few hundred watts of power.

Changes in the *1999 NEC* in Section 690.10 clarified some of the code requirements for stand-alone PV systems.

The local inspection authority has the final say on what is, or is not, required and what is, or is not, safe. Reasoned conversations may result in a liberal interpretation of the Code. For a new dwelling, it seems appropriate to install a complete ac electrical system as required by the *NEC*. This will meet the requirements of the inspection authority, the mortgage company, and the insurance industry. Then the PV system and its dc distribution system can be added. If an inverter is used, it can be connected to the ac service entrance. *NEC* Section 690.10 elaborates on these requirements and allowances. DC branch circuits and outlets can be added where needed, and everyone will be happy. If or when grid power becomes available, it can be integrated into the system with minimum difficulty. If the building is sold at a later date, it will comply with the *NEC* if it has to be inspected. The use of a listed dc power center will facilitate the installation and the inspection.

Square D has received a direct current (dc), UL listing for its standard QO residential **branch** circuit breakers. They can be used up to 48 volts (125% PV open-circuit voltage) and 70 amps dc. This limits their use to a 12-volt nominal system and a few 24-volt systems in hot climates [Table 690.7]. The AIR is 5,000 amps, so a current-limiting fuse (RK5 or RK1 type) **must** be used when they are connected on a battery system [690.71(C)]. The Square D QOM **main** breakers (used at the top of the load center) **do not** have this listing, so the dc load center based on Square D QO circuit breakers should be obtained with main lugs and no main breakers (Appendix A).

In a small 12-volt PV system (less than 5000 amps of available short-circuit current), a two-pole Square D QO breaker could be used as the PV disconnect (one pole) and the battery disconnect (one pole). Alternatively, a fused disconnect or fusible pullout could be used in this configuration. This would give a little more flexibility since the fuses can have different current ratings. Figure 19 shows both systems with only a single branch circuit.

In a system with several dc branch circuits, the Square D QO load center can be used. A standard, off-the-shelf Square D QO residential load center without a main breaker can be used for a dc distribution panel in 12-volt dc systems and a very few hot-climate 24-volt systems. The main disconnect would have to be a “back fed” QO breaker, and it would have to be connected in one of the normal branch circuit locations. Back-fed circuit breakers **must** be identified for such use [690.64(B)(5)] and clamped [408.16(F)]. See Appendix C for additional details. Since the load center has two separate circuits (one for each line), the bus bars will have to be tied together in order to use the entire load center. Figure 24 illustrates this use of the Square D load center.

Another possibility is to use one of the line circuits to combine separate PV source circuits, then go out of the load center through a breaker acting as the PV disconnect switch to the charge controller. Finally, the conductors would have to be routed back to the other line circuit in the load center for branch-circuit distribution. Several options exist in using one and two-pole breakers for disconnects. Figure 25 presents an example.

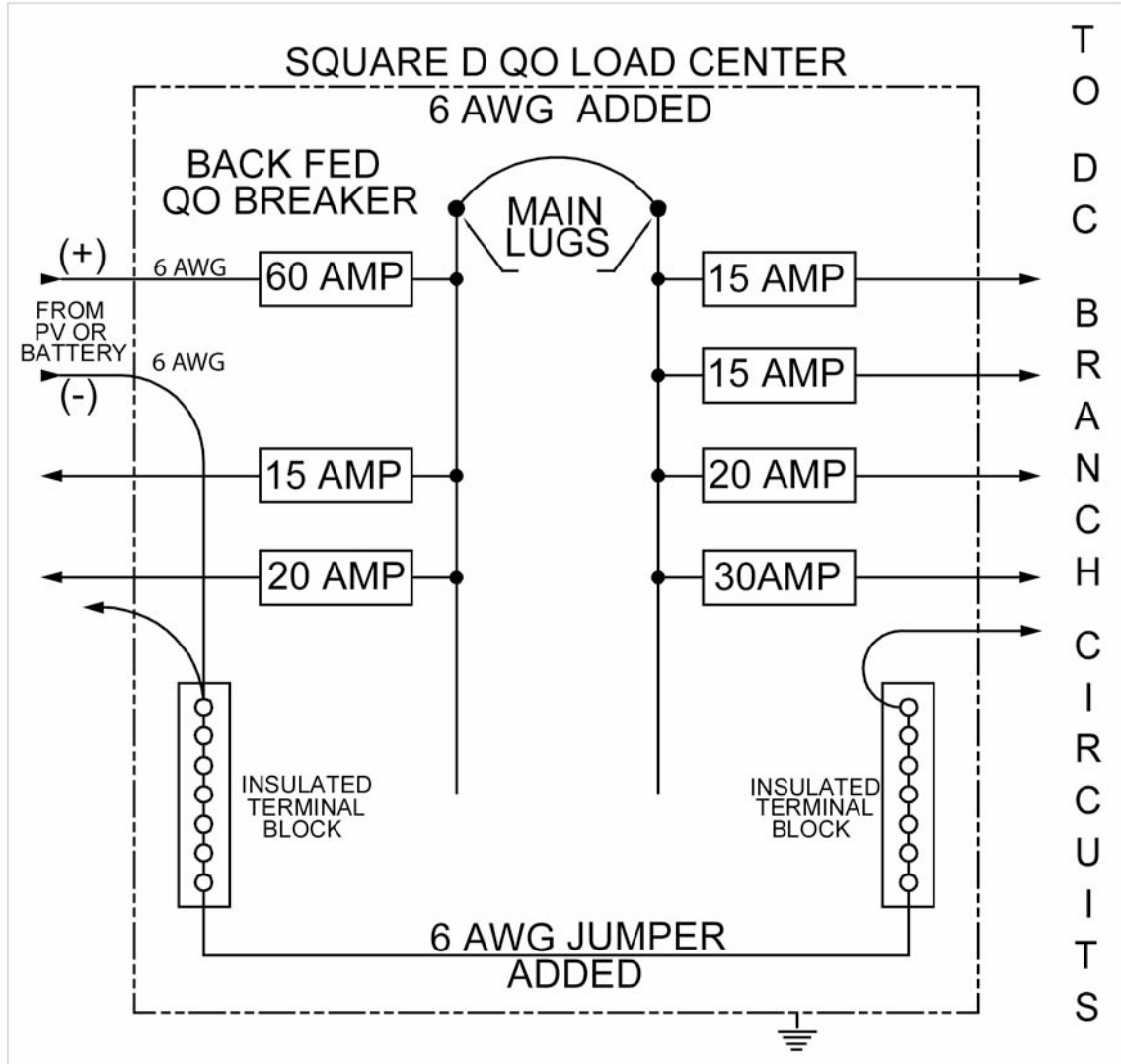

Figure 24. 12-Volt DC Load Center

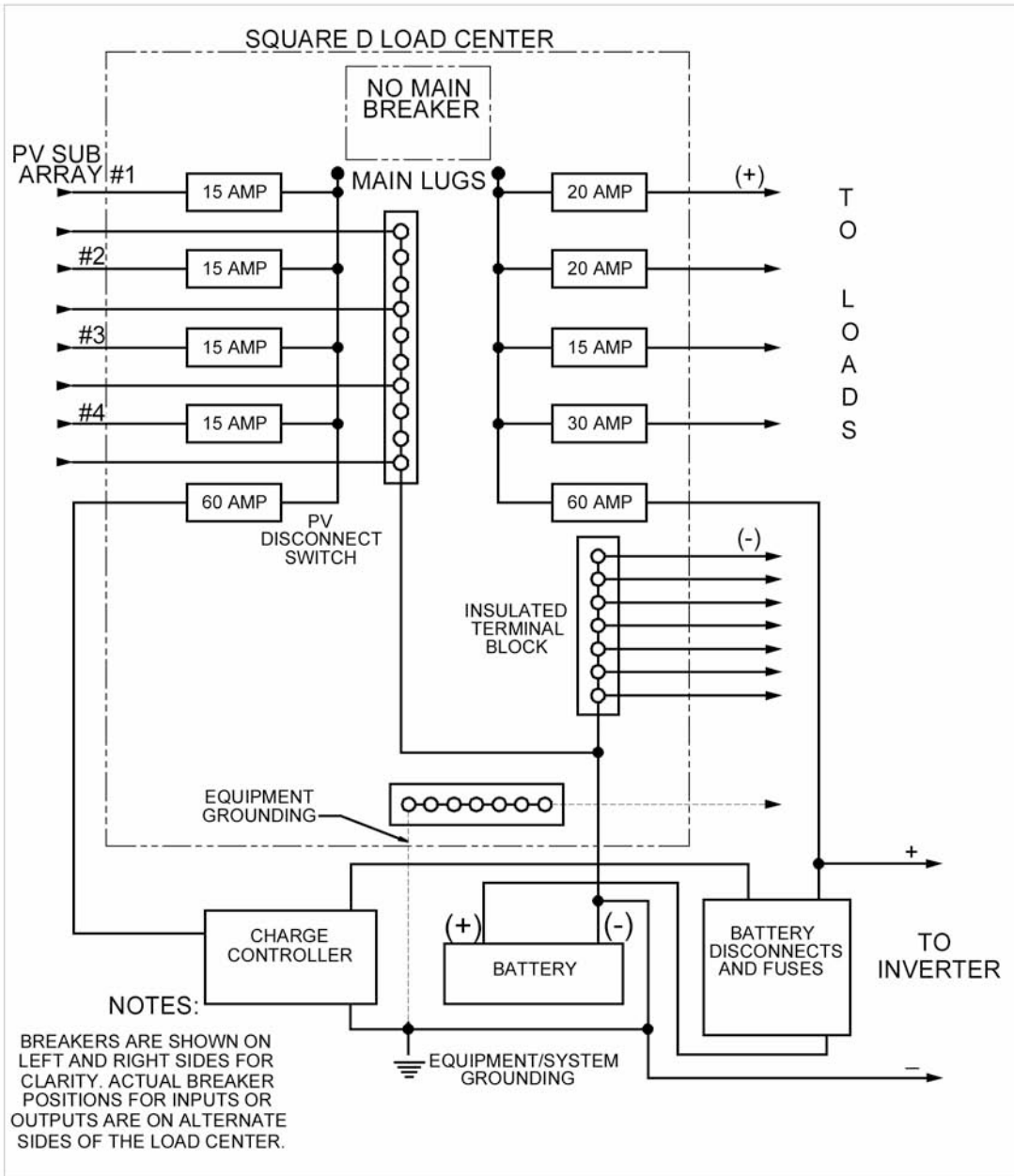

Figure 25. 12-Volt DC Combining Box and Load Center

INTERIOR DC WIRING AND RECEPTACLES

Any dc interior wiring used in PV systems **must** comply with the *NEC* [300]. Nonmetallic sheathed cable (type NM - "Romex") may be used, and it **must** be installed in the same manner as cable for ac branch circuits [334, 690.31(A)]. The bare grounding conductor in such a cable **must not** be used to carry current and cannot be used as a common negative conductor for combination 12/24-volt systems [334.108]. Exposed, single-conductor cables are not permitted—they **must** be installed in conduit [300.3(A)]. Conductors in the same current (i.e.,

positive and negative battery conductors and equipment-grounding conductors) **must** be installed in the same conduit or cable to prevent increased circuit inductances that would pose additional electrical stresses on disconnect and overcurrent devices [300.3(B)].

The code allows the equipment-grounding conductors for dc circuits *only* to be run apart from the current-carrying conductors [250.134(B) EX2]. However, separating the equipment-grounding conductor from the circuit conductors may increase any fault-circuit time constant and impair the operation of overcurrent devices. The effects of transient pulses are also enhanced when equipment-grounding conductors are separate. It is suggested that dc equipment-grounding conductors be run in the same conduit or cable as the dc circuit conductors.

The receptacles used for dc **must** be different from those used for any other service in the system [406.3(F)]. The receptacles should have a rating of not less than 15 amps and **must** be of the three-prong grounding type [406.2(B), 406.3(A)]. Numerous different styles of listed receptacles are available that meet this requirement. These requirements can be met in most locations by using the three-conductor 15-, 20-, or 30-amp 240-volt NEMA style 6-15, 6-20, 6-30 receptacles for the 12-volt dc outlets. If 24-volt dc is also used, the NEMA 125-volt locking connectors, style L5-15 or L5-20, are commonly available. The NEMA FSL-1 is a locking 30-amp 28-volt dc connector, but its availability is limited. Figure 26 shows some of the available configurations. Cigarette lighter sockets and plugs frequently found on “PV” and “RV” appliances *do not* meet the requirements of the *National Electrical Code* and should not be used.

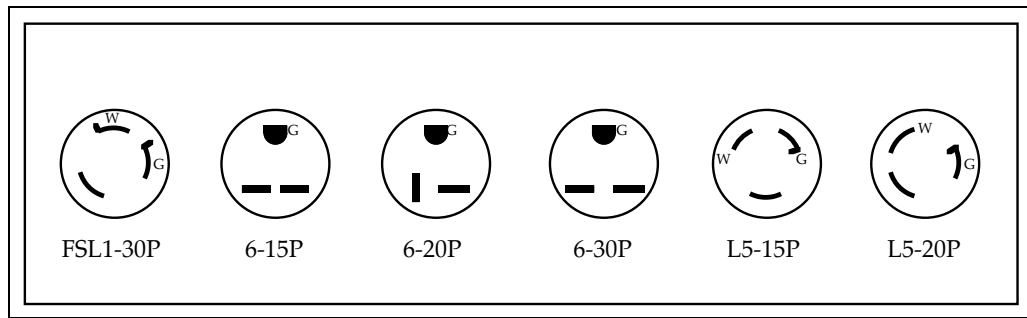

Figure 26. NEMA Plug Configurations

It is not permissible to use the third or grounding conductor of a three-conductor plug or receptacle to carry common negative return currents on a combined 12/24-volt system. This terminal **must** be used for equipment grounding and may not carry current except in fault conditions [406.9(C)].

A 30-amp fuse or circuit breaker protecting a branch circuit (with 10 AWG conductors) **must** use receptacles rated at 30 amps. Receptacles rated at 15 and 20 amps **must not** be used on this 30-amp circuit [Table 210.21(B)(3)].

SMOKE DETECTORS

Many building codes require that smoke and fire detectors be wired directly into the ac power wiring of the dwelling. With a system that has no inverter, two solutions might be offered to the inspector. The first is to use the 9-volt or other primary-cell, battery-powered detector. The second is to use a voltage regulator to drop the PV system voltage to the 9-volt or other level required by the detector.

The regulator should be able to withstand the PV open-circuit voltage and supply the current required by the detector alarm. Building such a device should only be attempted by the well-qualified individual.

On inverter systems, the detector on some units may trigger the inverter into an “on” state, unnecessarily wasting power. In other units, the alarm may not draw enough current to turn the inverter on and thereby produce a reduced volume alarm or, in some cases, no alarm at all. Small, dedicated inverters might be used, but this would waste power and decrease reliability when dc detectors are available.

Most building codes require detectors to be connected to the power line and have a battery backup. Units satisfying this requirement might also be powered by dc from the PV system battery and by a primary cell.

GROUND-FAULT CIRCUIT INTERRUPTERS

Some ac ground-fault circuit interrupters (GFCI) do not operate reliably on the output of some non-sine-wave inverters. If the GFCI does not function when tested, it should be verified that the neutral (white-grounded) conductor in the system is solidly grounded and bonded to the equipment-grounding (green or bare) conductor and both are connected to ground in the required manner. If this bond is present and does not result in the GFCI testing properly, other options are possible. Changing the brand of GFCI may rectify the solution. A direct measurement of an intentional ground fault may indicate that slightly more than the 5 milliamp internal test current is required to trip the GFCI. The inspector may accept this. Some modified square wave inverters will work with a ferro-resonant transformer to produce a waveform more satisfactory for use with GFCIs, but the no-load power consumption may be high enough to warrant a manual demand switch. A sine-wave inverter should be used to power those circuits requiring GFCI protection. Since sine-wave stand-alone inverters are becoming the norm, the problems of using GFCIs (and smoke detectors) with non sine-wave inverters are diminishing.

INTERIOR SWITCHES

Switches rated for *ac only* **shall not** be used in dc circuits [404.14(A)]. AC-DC general-use “snap” switches are available by special order from most electrical supply houses, and they are similar in appearance to normal “quiet switches” [404.14(B)].

Note: There have been some failures of dc-rated snap switches when used as PV array and battery disconnect switches. If these switches are used on 12- and 24-volt systems and are not activated frequently, the contacts may build up oxidation or corrosion and not function properly. Periodically (recommend monthly) activating the switches under load will keep the contacts clean.

MULTIWIRE BRANCH CIRCUITS

Stand-alone PV and PV/Hybrid systems are frequently connected to a building/structure/house that has been previously completely wired for 120/240-volts ac and has a standard service entrance and load center.

These structures may employ one or more circuits that the *National Electrical Code (NEC)* defines as a multiwire branch circuit. See Section 100 in the *NEC*, “Branch Circuit, Multiwire.” These circuits take a three-conductor plus ground feeder from the 120/240-volt load center and run it some distance to a location in the structure where two separate 120-volt branch circuits are split out. Each branch circuit uses one of the 120-volt hot, ungrounded conductors from the 120/240-volt feeder and the common neutral conductor. See Figure 27.

In a utility-connected system or a stand-alone system with a 120/240-volt stacked pair of inverters, where the 120/240-volt power consists of two 120-volt lines that are 180 degrees out of phase, the currents in the common neutral in the multiwire branch circuit are limited to the difference currents from any unbalanced load. If the loads on each of the separate branch circuits were equal, then the currents in the common neutral would be zero.

A neutral conductor overload may arise when a single 120-volt inverter is tied to both of the hot input conductors on the 120/240-volt load center as shown in Figure 27. This is a common practice for stand-alone PV homes. At this point the two hot 120-volt conductors are being delivered voltage from the single 120-volt inverter and that voltage is in phase on both conductors. In multiwire branch circuits, the return currents from each of the separate branch circuits in the common neutral *add* together. A sketch of the multiwire branch circuit is presented in Figure 27.

Each branch circuit is protected by a circuit breaker in the ungrounded conductor in the load center. The neutral conductor is usually the same size as the ungrounded conductors and can be overloaded with the in-phase return currents. The circuit breakers will pass current up to the ampacity of the protected conductors, but when both branch circuits are loaded at more than 50%, the unprotected, common neutral conductor is *overloaded and may be carrying up to twice its rated currents*.

A definite fire and safety hazard exists. All existing stand-alone PV installations using single inverters tied to both ungrounded conductors at the service entrance should be examined for multiwire branch circuits.

The *NEC* requires that multiwire branch circuits *in some, but not all, cases* use a two-pole circuit breaker so that both circuits are dead at the same time under fault conditions and for servicing. This two-pole, side-by-side circuit breaker rated at 15 or 20 amps may be one indication that multiwire branch circuits have been used. Common handle circuit breakers rated at 30 amps and higher are usually dedicated to 240-volt circuits for ranges, hot water heaters, dryers, and the like and the conductors are usually 8 AWG and larger. The Code requires that there **must** be no 240-volt outlets in a structure fed by a single 120-volt inverter [690.10].

Examination of the wiring in the load center may show a three-wire cable (14 or 12 AWG red, black, and white conductors) with bare ground leaving the load center. This may be connected to a multiwire branch circuit. The circuit breakers connected to this cable and the outputs of this cable should be traced to determine the presence or absence of a multiwire branch circuit.

The following options are suggested for dealing with this situation:

- *Disconnect or rewire the multiwire circuits as separate circuits ("home runs") from the load center.*
- *Connect both "hot" (ungrounded) conductors of the multiwire branch circuit to a single circuit breaker rated for the ampacity of the neutral conductor. Note: This may violate local code limitations on the number of outlets per branch circuit.*
- *Install a transformer to provide a 120/240-volt output from a 120-volt inverter.*
- *Install a stacked pair of inverters to provide 120/240V ac.*

In systems where multiwire branch circuits are used with stacked (120/240-volt) inverters, a sign should be placed near the inverters warning that single inverter use (one inverter removed for repair and the system is rewired to accommodate all branch circuits) may cause overloaded circuits. The maximum current from the single inverter should be limited to the ampacity of the common neutral conductor.

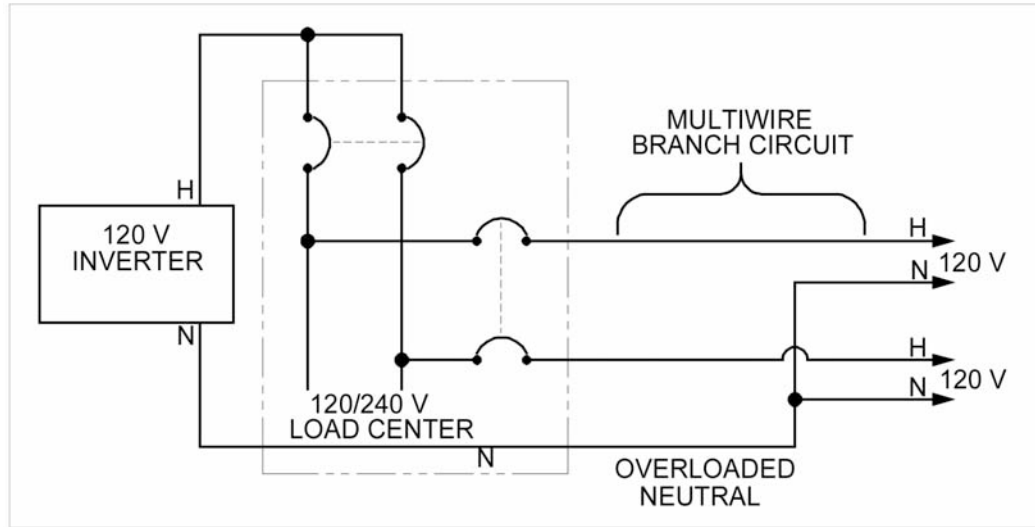

Figure 27. Diagram of a Multiwire Branch Circuit

In all systems (multiwire or not), the neutral busbar of the load center **must** be rated at a higher current than the output of the inverter [690.10(C)]. In other words, do not connect an inverter with a 33-amp output to a load center rated at 20 or 30 amps.

Additional information is found in the *NEC* in sections 100, 210.4, 240.20(B), and 300.13(B), and in the *NEC Handbook*. Section 690.10(C) provides requirements and allowances on connecting a single inverter to a code-compliant ac wiring system.

AC PV MODULES

An AC PV module is a photovoltaic device that has an alternating current output (usually 120 volts at 60 Hz in the U.S.). The AC PV module is listed (by UL and other listing agencies) as a unified device and is actually a standard dc PV module with an attached (non-removable) utility-interactive inverter. The ac output is only available when the ac PV module is connected to a utility grid circuit where there is a stable 120 volts at 60 Hz present. With no utility power, there will be NO energy flow from the ac PV modules.

A number of ac PV modules may be connected on the same circuit (according to ampacity limitations), but that circuit **must** be dedicated to the ac PV module(s) and **must** terminate in a dedicated circuit breaker [690.6].

There are no external dc circuits in the ac PV module and none of the dc code requirements apply. Unlisted combinations of small listed inverters mated to listed dc PV modules do not qualify as an ac PV module and will have to have all code-required dc switchgear, overcurrent, and ground-fault equipment added.

AC PV modules **shall** be marked with the following:

- Nominal AC Voltage
- Nominal AC Frequency
- Maximum AC Power
- Maximum AC Current
- Maximum Overcurrent Device Rating for AC Module Protection [690.52]

SYSTEM LABELS AND WARNINGS

PHOTOVOLTAIC POWER SOURCE

A permanent label **shall** be applied near the PV disconnect switch that contains the following information: [690.53]

- Operating Current (System maximum-power current)
- Operating Voltage (System maximum-power voltage)
- Maximum System Voltage
- Short-Circuit Current

This data will allow the inspector to verify proper conductor ampacity and overcurrent device rating. It will also allow the user to compare system performance with the specifications.

MULTIPLE POWER SYSTEMS

Systems with multiple sources of power such as PV, gas generator, wind, hydro, etc., **shall** have a permanent plaque or directory showing the interconnections [705.10]. Diagrams are not required, but may be useful and should be placed near the system disconnects.

INTERACTIVE SYSTEM POINT OF INTERCONNECTION

All interactive system(s) points of interconnection with other sources **shall** be marked at an accessible location at the disconnecting means as a power source with the maximum ac output operating current and the operating ac voltage [690.54].

SWITCH OR CIRCUIT BREAKER

If a switch or circuit breaker has all of the terminals energized when in the open position, a label should be placed near it indicating: [690.17]

WARNING - ELECTRIC SHOCK HAZARD - DO NOT TOUCH TERMINALS. TERMINALS ON BOTH THE LINE AND LOAD SIDES MAY BE ENERGIZED IN THE OPEN POSITION

GENERAL

Each piece of equipment that might be opened by unqualified persons should be marked with warning signs. In some cases, a listed product is required to have similar warnings:

WARNING - ELECTRIC SHOCK HAZARD - DANGEROUS VOLTAGES AND CURRENTS - NO USER SERVICEABLE PARTS INSIDE - CONTACT QUALIFIED SERVICE PERSONNEL FOR ASSISTANCE

Each battery container, box, or room should also have warning signs to encourage safety for both qualified and unqualified people:

WARNING - ELECTRIC SHOCK HAZARD - DANGEROUS VOLTAGES AND CURRENTS - EXPLOSIVE GAS - NO SPARKS OR FLAMES - NO SMOKING - ACID BURNS - WEAR PROTECTIVE CLOTHING WHEN SERVICING

INSPECTIONS

Involving the inspector as early as possible in the planning stages of the system will begin a process that should provide the best chance of installing a safe, durable system. The following steps are suggested.

- Establish a working relationship with a local electrical contractor or electrician to determine the requirements for permits and inspections.
- Contact the inspector and review the system plans. Solicit advice and suggestions from the inspector.
- Obtain the necessary permits.
- Involve the inspector in the design and installation process. Provide information as needed. Have one-line diagrams and complete descriptions of all equipment available.

INSURANCE

Most insurance companies are not familiar with photovoltaic power systems. They are, however, willing to add the cost of the system to the homeowner's policy if they understand the additional liability risk. A system description may be required. Evidence that the array is firmly attached to the roof or ground is usually necessary. The system **must** usually be permitted and inspected if those requirements exist for other electrical power systems in the locale [Local Codes].

Some companies will not insure homes that are not grid connected because there is no source of power for a high-volume water pump for fighting fires. In these instances, it may be necessary to install a fire-fighting system and water supply that meets their requirements. A high-volume dc pump and a pond might suffice.

As with the electrical inspector, education and a full system description emphasizing the safety features and code compliance will go a long way toward obtaining appropriate insurance.

APPENDIX A: Sources of Equipment Meeting the Requirements of The *National Electrical Code*

A number of PV distributors and dealers stock the equipment needed to meet the *NEC* requirements. Some sources are presented here for specialized equipment. This list is not intended to be all-inclusive or to promote any of the products.

CONDUCTORS

Standard multiconductor cable such as 10-2 with ground Nonmetallic Sheathed Cable (NM and NMC), Underground Feeder (UF), Service Entrance (SE), Underground Service Entrance (USE and USE-2), larger sizes (8 AWG) single-conductor cable, uninsulated grounding conductors, and numerous styles of building wire such as THHN can be obtained from electrical supply distributors and building supply stores. See *NEC* Table 310-13 for cable types and characteristics.

Flexible, fine-stranded cables should not be used with terminals or lugs that have a setscrew or screw mechanical attachment. These terminals and lugs (also found on circuit breakers, fuse holders, and PV equipment) are not generally listed for use with other than normal 7, 19, and 37 stranded conductors. Appendix K presents additional details.

The highest quality, most durable USE-2 cable will also have RHW-2, and 600V markings and be made of cross-linked polyethylene (marked XLP or XLPE). Flexible USE, RHW, and THW cables in large sizes (1/0 - 250 kcmil) and stranded 8-, 10-, and 12-AWG USE single conductor cable can be obtained from electrical supply houses and wire distributors. The following short list provides information on a cable distributor and manufacturer.

Anixter Bros.
2201 Main Street
Evanston, Illinois 60202
800-323-8166 for the nearest distributor
847-677-2600

Cobra Wire and Cable, Inc.
PO Box 790
2930 Turnpike Drive
Hatboro, PA 19040
215-674-8773

DC-RATED FUSES

DC-rated 15, 20, 30 amp and higher rated fuses can be used for dc branch-circuit overcurrent protection depending on conductor ampacity and load. Larger sizes (100 amp and up) are used for current-limiting and overcurrent protection on battery outputs. DC rated, listed fuses are manufactured by the following companies, among others:

Bussmann
P.O. Box 14460
St. Louis, MO 63178-4460
314-527-3877
314-527-1270 (Technical Questions)

Ferraz Shawmut
374 Merrimac Street
Newburyport, MA 01950
978-462-6662

Littelfuse
Power Fuse Division
800 E. Northwest Highway
Des Plaines, Illinois 60016
(708) 824-1188
800-TEC FUSE (Technical Questions)
800-227-0029 (Customer Service)

The following fuses may be used for battery circuit and dc branch circuit overcurrent protection and current limiting applications. If transients are anticipated in PV circuits, these fuses can also be used in those locations.

Fuse Description	Size	Manufacturer	Mfg #
125-volt dc, RK5 Time delay, current-limiting	0.1-600 amp	Bussmann	FRN-R
125-volt dc, RK5 Time delay, current-limiting	0.1-600 amp	Littelfuse	FLNR
300-volt dc, RK5 Time delay, current-limiting fuse	0.1-600-amp	Bussmann	FRS-R
300-volt dc, RK5 Time delay, current-limiting fuse	0.1-600 amp	Ferraz	TRS-R
300-volt dc, RK5 Time delay, current-limiting fuse	0.1-600 amp	Littelfuse	FLSR
600-volt dc, RK5 Time delay, current-limiting fuse	0.1-600 amp,	Littelfuse	IDSR

The following fuses should be used for PV source-circuit protection if problems are not anticipated with transients. They may also be used inside control panels to protect relays and other equipment.

Fuse Description	Size	Manufacturer	Mfg #
Fast-acting, midget fuse	0.1-30 amp	Ferraz	ATM
Fast-acting, midget fuse	0.1-30 amp	Littelfuse	KLK-D

ENCLOSURES AND JUNCTION BOXES

Indoor and outdoor (rainproof) general-purpose enclosures and junction boxes are available at most electrical supply houses. These devices usually have knockouts for cable entrances, and the distributor will stock the necessary bushings and/or cable clamps. Interior component mounting panels are available for some enclosures, as are enclosures with hinged doors. If used outdoors, all enclosures, clamps, and accessories **must** be listed for outdoor use [110.3(B)]. For visual access to the interior, NEMA 4X enclosures are available that are made of clear, transparent plastic.

HYDROCAPS

Hydrocap® Vents are available from Hydrocap Corp. and some PV distributors on a custom-manufactured basis.

Hydrocap
975 NW 95 St.
Miami, FL 33150
305-696-2504

APPENDIX B: PV Module Operating Characteristics Drive *NEC* Requirements

INTRODUCTION

As the photovoltaic (PV) power industry moves into a mainstream position in the generation of electrical power, some people question the seemingly conservative requirements established by Underwriters Laboratories (UL) and the *National Electrical Code (NEC)* for system and installation safety. This short discourse will address those concerns and highlight the unique characteristics of PV systems that dictate the requirements.

The *National Electrical Code (NEC)* is written with the requirement that all equipment and installations are approved for safety by the authority having jurisdiction (AHJ) to enforce the *NEC* requirements in a particular location. The AHJ readily admits to not having the resources to verify the safety of the required equipment and relies exclusively on the testing and listing of the equipment by independent testing laboratories such as Underwriters Laboratories (UL). The AHJ also relies on the installation requirements for field wiring specified in the *NEC* to ensure safe installations and use of the listed equipment.

The standards published by UL and the material in the *NEC* are closely harmonized by engineers and technicians throughout the electrical equipment industry, the electrical construction trades, the national laboratories, the scientific community, and the electrical inspector associations. The UL Standards are technical in nature with very specific requirements on the construction and testing of equipment for safety. They in turn are coordinated with the construction standards published by the National Electrical Manufacturers Association (NEMA). The *NEC*, however, is deliberately written in a manner to allow uniform application by electricians, electrical contractors, and electrical inspectors in the field.

The use of listed equipment (by UL or other nationally recognized testing laboratory) ensures that the equipment meets well-established safety standards. The application of the requirements in the *NEC* ensures that the listed equipment is properly connected with field wiring and is installed in a manner that will result in an essentially hazard-free system. The use of listed equipment and installing that equipment according to the requirements in the *NEC* will contribute greatly not only to safety, but also the durability, performance, and longevity of the system.

UNSPECIFIED DETAILS

The *NEC* does not present many highly detailed technical specifications. For example, the term "rated output" is used in several cases with respect to PV equipment. The conditions under which the rating is determined are not specified. The definitions of the rating conditions (such as Standard Test Conditions (STC) for PV modules) are made in the UL Standards that establish the rated output. This procedure is appropriate because of the *NEC* level of writing and the lack of appropriate test equipment available to the *NEC* user or inspector.

NEC REQUIREMENTS BASED ON MODULE PERFORMANCE

Voltage

Section 690.7 of the *NEC* establishes a temperature-dependent voltage correction factor that is to be applied to the rated (at STC) open-circuit voltage (V_{oc}) in order to establish the system voltage. This factor on the open-circuit voltage is needed because, as the operating temperature of the module decreases, V_{oc} increases. The rated V_{oc} is measured at a temperature of 25°C and while the normal operating temperature is 40-50°C when ambient temperatures are around 20°C, there is nothing to prevent sub-zero ambient temperatures from yielding operating temperatures significantly below the 25°C standard test condition.

A typical crystalline silicon module will have a voltage coefficient of -0.38%/°C. A system with a rated open-circuit voltage of 595 volts at 25°C might be exposed to ambient temperatures of -30°C. This voltage (595V) could be handled by the common 600-volt rated conductors and switchgear. At dawn and dusk conditions, the module will be at the ambient temperature of -30°C, will not experience any significant solar heating, and can generate open-circuit voltages of 719 volts ($595 \times (1 + (25 - 30) \times -0.0038)$). This voltage substantially exceeds the capability of 600-volt rated conductors, fuses, switchgear, and other equipment. High wind speeds can also cause modules to operate at or near ambient temperatures, even in the presence of moderate levels of sunlight. The very real possibility of this type of condition substantiates the *NEC* requirement for the temperature dependent factor on the rated open-circuit voltage.

Thin-film PV technologies may have other voltage-temperature relationships, and the manufacturers of modules employing such technologies should be consulted for the appropriate data.

Current

NEC Section 690.8(A) requires that the rated (at STC) short-circuit current of the PV module be multiplied by 125% before any other factors, such as continuous current and conduit fill factors, are applied. This factor is to provide a safe margin for wire sizes and overcurrent devices when the irradiance exceeds the standard 1000 W/m^2 . Depending on season, local weather conditions, and atmospheric dust and humidity, irradiance exceeds 1000 W/m^2 every day around solar noon. The time can be as long as four hours with irradiance values that approach 1200 W/m^2 , again depending on the aforementioned conditions and the type of tracking system being used. These daily irradiance values can increase short-circuit currents 20% over the 1000 W/m^2 value. Since these increased currents can be present for three hours or more, they are considered continuous currents. By multiplying the short-circuit current by 125%, the PV output currents are adjusted in a manner that puts them on the same basis as other continuous currents in the *NEC*

Enhanced irradiance due to reflective surfaces such as sand, snow, or white roofs, and even nearby bodies of water can increase short-circuit currents by substantial amounts and for significant periods of time. Reflections from cumulus clouds also can increase irradiance by as much as 50%. These transient factors are not considered continuous and are not addressed by either UL or the *NEC*

Another factor that needs to be addressed is that PV modules typically operate at 30-40°C above the ambient temperatures when not exposed to cooling breezes. In crystalline silicon PV modules, the short-circuit current increases as the temperature increases. A typical factor might be 0.1%/°C. If the module operating temperature was 60°C (35°C over the STC of 25°C), the short-circuit current would be 3.5% greater than the rated value. PV modules have been measured operating over 75°C. The combination of increased operating temperatures, irradiances over 1000 W/m^2 around solar noon, and the possibility of enhanced irradiance provide additional justification for the *NEC* requirement [690.8(A)] of 125% on the rated short-circuit current.

ADDITIONAL *NEC* REQUIREMENTS

The *NEC* requires that the continuous current of any circuit be multiplied by 125% before calculating the ampacity of any cable or the rating of any overcurrent device used in these circuits [690.8(B) and 240]. This factor is in addition to the required 125% discussed above and is needed to ensure that overcurrent devices and conductors are not operated above 80% of rating.

Since short-circuit currents in excess of the rated value are possible from the discussion of the Section 690.8(A) requirements above, and these currents are independent of the requirements established by Section 690.8(B), the *NEC*

dictates that both factors will be used at the same time. This yields a multiplier on short-circuit current of 1.56 (125% x 125%).

The *NEC* also requires that the ampacity of conductors be derated for the operating temperature of the conductor. This is a requirement because the ampacity of cables is given for cables operating in an ambient temperature of 30°C. In PV systems, cables are operated in an outdoor environment and should be subjected at least to a temperature derating due to an ambient temperature of 40°C to 45°C. PV modules operate at high temperatures and, in some installations, may be over 75°C. Concentrating modules operate at even higher temperatures. The temperatures in module junction boxes approach these temperatures. Conductors in free air that lie against the back of these modules are also exposed to these temperatures. These high temperatures require that the ampacity of cables be derated by factors of 0.33 to 0.58 depending on cable type, installation method (free air or conduit), and the temperature rating of the insulation [310.16, 310.17].

Cables in conduit where the conduit is exposed to the direct rays of the sun are also exposed to elevated operating temperatures.

Cables with insulation rated at 60°C have no ampacity at all when operated in environments with ambient temperatures over 55°C. This precludes their use in most PV systems. Cables with 75°C insulation have no ampacity when operated in ambient temperatures above 70°C. Because PV modules may operate at temperatures in the 45-75°C range, it is strongly suggested that only cables with an insulation rated at 90°C be used.

SUMMARY

The conditions under which PV modules operate (high and low ambient temperatures, high and low winds, high and low levels of sunlight) and the electrical characteristics of those modules dictate that all of the requirements in the *NEC* be fully considered and applied.

There appears to be little question that the temperature-dependent correction factor on voltage is necessary in any location where the ambient temperature drops below 25°C. Even though the PV system can provide little current under open-circuit voltage conditions, these high voltages can damage electronic equipment and stress conductors and other equipment by exceeding their voltage breakdown ratings.

In ambient temperatures from 25 to 40°C and above, module short-circuit currents are increased at the same time conductors are being subjected to higher operating temperatures. Irradiance values over the standard rating condition may occur every day. Therefore the *NEC* requirements for adjusting the short-circuit current are necessary to ensure a safe and long-lived system.

APPENDIX C: Utility-Interactive Systems

Utility-interactive (grid-connected) systems present some unique challenges for the PV designer and installer in meeting the *NEC*.

INVERTERS

Utility-interactive inverters that connected to the utility grid should meet the requirements established by *UL Standard 1741* and be so listed. Some of the larger inverters cannot have both the dc PV circuits and the ac output circuits grounded as required by code without causing operational and functional problems. These units require an external ac isolation transformer. Newer versions of these inverters may have solutions for this problem, and the *2005 NEC* will allow ungrounded PV systems as are used in Europe.

UTILITY CONNECTION

NEC part 690 VII and section 690.64 provide some detailed requirements for connecting the utility-interactive inverter to the utility. Most are relatively clear. However, 690.64(B)(2) needs elaboration. Consider the diagram of a backfed commercial load center shown in Figure C1.

In this figure, a 400-amp load center has a 400-amp main breaker (a common arrangement where the main breaker is sized the same as the load center rating). The maximum continuous loads on the load center, in a properly designed system, should not exceed 320 amps (80% of the main breaker rating). Although the sum of the rating of the circuit breakers *supplying loads* connected to the panel will usually significantly exceed the rating of the panel, the actual loads should be less than 320 amps. Otherwise, the main breaker would trip on the overloads, thereby protecting the load center and the feeder.

A utility-interactive PV system is connected to this panel through a 100-amp backfed circuit breaker installed as shown at or near the top of the load center. As long as the loads on the system do not exceed 320 amps, no problems exist as far as safety.

However, at some later date, the loads on the load center may increase. This may be due to added circuits, which should be installed by an electrician or by just increasing the existing plug loads. For example, office modules with outlets may be added with high desktop publishing loads. If the extra loads are present only during the daytime, the main breaker will not trip since the PV system will be picking up the excess loads. However, the bus bar in the load center at point B will be carrying more than its 400-amp rating. Up to 400 amps can be supplied to the load center through the main breaker and up to 100 amps can be supplied through the backfed PV breaker. This current of up to 500 amps will cause excess

heating of the bus bar. It may cause nuisance tripping of breakers in the load center and may also result in premature failure of the load center or the circuit breakers. No circuit breakers will be overloaded, none will trip, and no one will be alerted to the problem. In any event, the load center is being used in a manner for which it was not designed. In fact, NEC requirements generally dictate that the load center bus bars will not be required to handle more than 320 amps on a continuous basis.

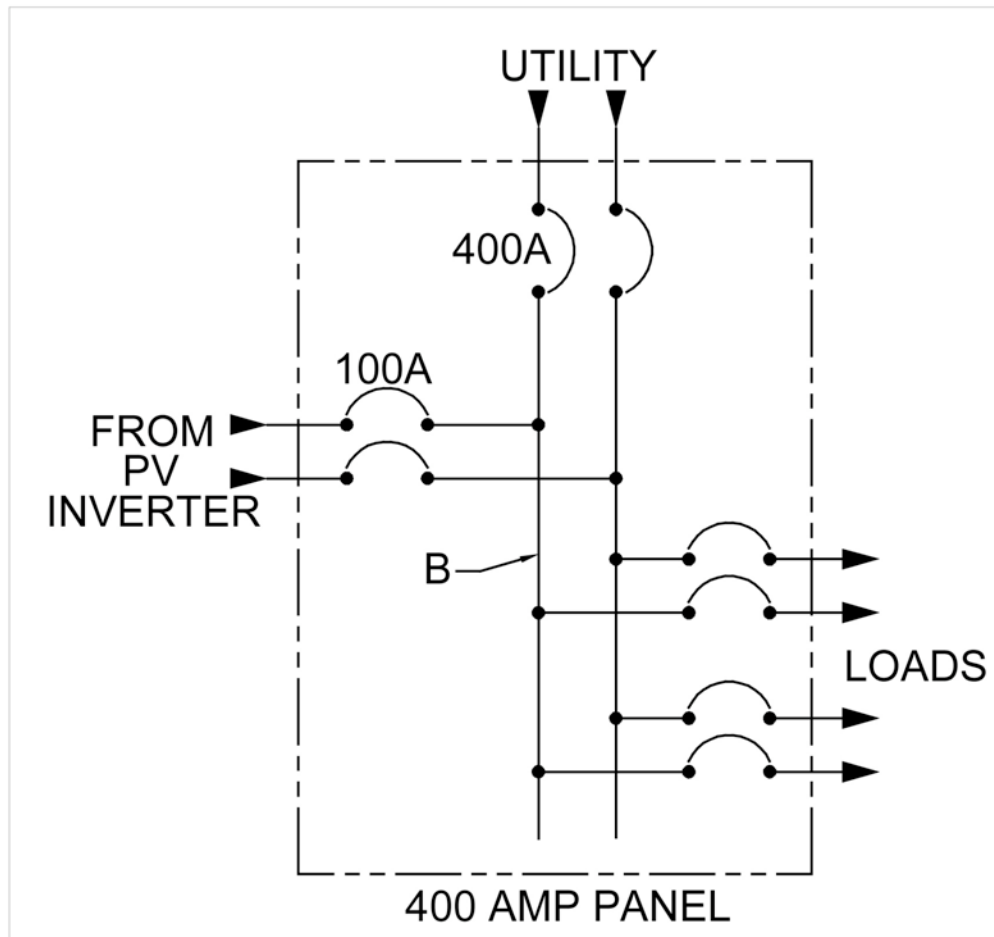

Figure C-1. 400 Amp Panel – Commercial PV Installation

Using the requirement of 690.64(B)(2) ensures that the currents being supplied by the PV system (as limited by the backfed breaker) plus the currents supplied by the utility (as limited by the main circuit breaker) will not exceed the rating of the load center. In commercial installations, each feeder panel subject to backfed PV currents **must** meet the requirements of 690.64(B)(2).

In commercial installations, the requirements of 690.64(B)(2) may be met in several ways.

- (1) If the existing load center is fully loaded (i.e. 320 amps on a 400-amp load center), then the load center may be replaced with a larger unit (i.e. 600 amps) with a smaller main breaker (i.e. 400 amps). This will leave 200 amps of capacity for backfeeding PV.
- (2) When an analysis of the electrical system reveals that several load centers (feeder panels) in the building need to be replaced/upgraded to handle backfed PV currents, it is usually easier to install a second service entrance on the building. In this case the service entrance conductors between the utility meter and the primary service disconnect can be tapped and routed to a dedicated disconnect which serves as a second service entrance just for the PV system.

PV SOURCE-CIRCUIT CONDUCTORS

Some older grid-tied inverters operate with PV arrays that are center tapped and have cold-temperature open-circuit voltages of ± 325 volts and above. The system voltage of 650 volts or greater exceeds the insulation rating of the commonly available 600-volt insulated conductors. Each disconnect and overcurrent device and the insulation of the wiring **must** have a voltage rating exceeding the system voltage rating [110.3(B)]. Type G and W cables are available with the higher voltage ratings, but are flexible cords and do not meet *NEC* requirements for fixed installations.

Other older inverters have been designed to operate on systems with open-circuit voltages exceeding ± 540 volts requiring conductors with 2000-volt or higher insulation. See Appendix D for a full discussion of this area.

OVERCURRENT DEVICES

When UL tests and lists fuses for dc operation, the voltage rating is frequently one-half the ac voltage rating. This results in a 600-volt ac fuse rated for 300-volt dc. Fuses with high enough dc ratings for grid systems operating at ± 300 volts or 600 volts to ground (600-volt system voltage) need to be carefully selected. There are a number of listed, dc-rated 600-volt fuses available. See Appendix A.

BACKFED CIRCUIT BREAKERS, THE *NATIONAL ELECTRICAL CODE* AND UL STANDARDS

Utility-Interactive PV Systems

1. Section 690.64(B)(5) of the *National Electrical Code (NEC)* requires that backfed circuit breakers be identified for the use.

Underwriters Laboratories (UL) standards indicate that any circuit breaker that is not marked “Line” and “Load” is identified as suitable for backfeeding. Most circuit breakers used in residential and commercial load centers are not marked “Line” and “Load” and are suitable for backfeeding.

It should be noted that when the ac output of a utility-interactive inverter is connected to a circuit breaker, the current/power flow through the breaker is indeed backward. The closed breaker, connected in only one of the current-carrying conductors, is not affected by which way the ac power or current is flowing. However, when a fault occurs in this circuit, it will be grid current flowing through the breaker in the forward direction toward a fault in the inverter side that causes the breaker to trip. There is no reverse current or backfeeding of current in this breaker under fault conditions.

2. Section 408.16(F) of the *NEC* requires that “plug-on” backfed circuit breakers be clamped to the load center.

This is certainly a valid requirement when the circuit breaker under discussion is a backfed main breaker. It would also be valid when the backfed breaker was connected to a voltage source such as a rotating generator. In both cases, pulling the circuit breaker from the load center bus bars could result in a energized surface (the plug-on contact) exposed on the breaker—either at grid voltage or voltage from the output of the generator. However, if an unqualified person has access the exposed panel, there is at least as great a hazard from the exposed bus bars and main lugs as from the possibly energized breaker contact.

This requirement also originated in the days of exposed industrial panel boards that did not have dead fronts and where the plug-on breakers were easily accessed and pulled off without much thought.

3. In PV systems, where the backfed breaker is being fed by the output of a utility-interactive PV inverter identified and listed for such use, the situation changes substantially.

IEEE Standard 1547 and UL Standard 1741 require that utility interactive inverters cease exporting power within 0.1 seconds upon loss of ac utility voltage (voltage below 50% of nominal). This means that when a backfed breaker from a PV utility-interactive inverter is pulled off of a load center bus bar, the breaker essentially becomes completely de-energized in a fraction of a second; probably before it is moved more than a small fraction of an inch away from the bus bars. There is no electric shock hazard from either terminal on the circuit breaker after it has been disconnected from the bus bar.

Furthermore all currently available load centers, both residential and commercial, have dead front covers that are fastened with one to four or more screws. This very effectively clamps all internal circuit breakers to the bus bars. Although not explicitly stated, there is an implicit “rule” in the code that a tool **must** be used to gain access to

energized circuits. This applies nearly universally from the screw-cover on an ac receptacle outlet or ac wall switch to the screw covers on terminal boxes and termination boxes for transformers, motors and other equipment. Section 690.64(B)(5) in the 2005 NEC no longer requires backfed circuit breakers connected to the output of a utility-interactive inverter to be clamped provided they are in a load center with a screw cover and are not backfed main breakers.

If the unqualified or qualified person gains access by removing the clamping front cover on a load center with backfed breakers, the exposed main lugs and the exposed bus bars pose greater immediate shock hazards than the backfed breaker which has not yet even been unplugged.

Summary

There appears to be no safety hazard (either shock or fire) that would require backfed circuit breakers connected to the output of utility-interactive PV inverters to be clamped to the load center bus bars.

DISCONNECTS

Many utility-interactive inverters operate at dc PV voltages in the 250-600 volt range and these voltages preclude the use of a circuit breaker as a dc disconnect. In most cases, a fused or unfused safety switch is used as a disconnect. These safety switches normally require that two of the three poles be wired in series to achieve the 600-volt dc rating and these two poles are then used to open the ungrounded positive PV conductor. This requirements dictate that one switch be used for each inverter or for each string of PV modules.

In the smaller inverters (up to about 3.5-4 kW), the dc currents are in the 10-15 amp range. Square D has obtained a special listing on their three-pole, 600-volt fused (H361/H362/H363) and unfused (HU361/HU362/HU363) Heavy Duty Safety Switches that allows them to be used on PV systems with only one switch pole per string of PV modules or one switch pole per inverter where the maximum currents are less than about 18 amps (rated short-circuit currents less than 11 amps) for the 361's and 60 or 100 amps for the 362 and 363 respectively.

BLOCKING DIODES

The *NEC* does not require blocking diodes. The language of the code simply allows their use, which is rapidly declining. The use of the required overcurrent device in each series string of modules provides the necessary reverse-current protection.

Blocking diodes are not overcurrent devices. They block reverse currents in direct-current circuits and help to control circulating ground-fault currents if used in both ends of high-voltage strings. Lightning induced surges are tough on

diodes. If isolated case diodes are used, at least 3500 volts of insulation is provided between the active elements and the normally grounded heat sink. Choosing a peak reverse voltage as high as is available but at least twice the PV open-circuit voltage will result in longer diode life. Substantial amounts of surge suppression will also improve diode longevity.

Blocking diodes may not be substituted for the *UL-1703* requirement for module protective fuses in each series-connected string of modules.

SURGE SUPPRESSION

Surge suppression is covered only lightly in the *NEC* because it affects system performance more than safety. Surges are a utility problem at the transmission line level in ac systems [280]. PV arrays mounted in the open, on the tops of buildings, act like lightning rods. The PV designer and installer should provide appropriate means to deal with lightning-induced surges coming into the system.

Array frame grounding conductors should be routed directly to supplementary ground rods located as near as possible to the arrays [250.54].

Metal conduit will add inductance to the array-to-building conductors and slow down any induced surges as well as provide some electromagnetic shielding.

Metal oxide varistors (MOV) commonly used as surge suppression devices on electronic equipment have several deficiencies. They draw a small amount of current continually. The clamping voltage lowers as they age and may reach the open-circuit voltage of the system. When they fail, they fail in the shorted mode, heat up, and frequently explode or catch fire. In many installations, the MOVs are protected with fast acting fuses to prevent further damage when they fail, but this may limit their effectiveness as surge suppression devices. Other electronic devices are becoming available that do not change performance characteristics as they age or are subjected to surges.

Several companies specialize in lightning protection equipment, but much of it is for ac systems. Electronic product directories, such as the *Electronic Engineers Master Catalog* should be consulted.

APPENDIX D: Cable and Device Ratings at High Voltages

There is a concern in designing PV systems that have system open-circuit voltages above 600 volts. The concern has two main issues—device ratings and *NEC* limitations.

EQUIPMENT RATINGS

Some discontinued, out of production, utility-intertie inverters operate with a grounded, bipolar (three-wire) PV array. In a bipolar PV system, where each of the monopoles is operated in the 220-235-volt peak-power range, the open-circuit voltage can be anywhere from 290 to 380 volts, depending on the module characteristics such as fill-factor. Such a bipolar system can be described as a 350/700-volt system (for example) in the same manner that a 120/240-volt ac system is described. This method of describing the system voltage is consistent throughout the electrical codes used not only in residential and commercial power systems, but also in utility practice.

In all systems, the voltage ratings of the cable, switchgear, and overcurrent devices are based on the higher number of the pair (i.e., 700 volts in a 350/700-volt system). That is why 250-volt switchgear and overcurrent devices are used in 120/240-volt ac systems and 600-volt switchgear is used in systems such as the 277/480-volt ac system. Note that it is not the voltage to ground, but the higher line-to-line voltage that defines the equipment voltage requirements.

The *National Electrical Code (NEC)* defines a nominal voltage for ac systems (120, 240, etc.) and acknowledges that some variation can be expected around that nominal voltage. Such a variation around a nominal voltage is not considered in dc PV systems, and the *NEC* requires that a temperature-related connection factor on the open-circuit array voltage **must** be used [690.7(A)]. The open-circuit voltage is defined at Standard Test Conditions (STC) because of the relationship between the UL Standards and the way the *NEC* is written. The *NEC Handbook* elaborates on the definition of “circuit voltage,” but this definition may not apply to current-limited dc systems. Section 690.7(A) of the *NEC* requires that the voltage used for establishing dc circuit requirements in PV systems be the computed open-circuit voltage for crystalline PV technologies. In new thin-film PV technologies, open-circuit voltages are determined from manufacturers’ specifications for temperature coefficients.

The Code specifically defines the PV system voltage as the product of a temperature-dependent factor (that may reach 1.25 at -40°C) and the STC open-circuit voltage [690.7]. The systems voltage is also defined as the highest voltage between any two wires in a 3-wire (bipolar) PV system [690.2].

The comparison to ac systems can be carried too far; there are differences. For example, the typical wall switch in a 120/240-volt ac residential or commercial

system is rated at only 120 volts, but such a switch in a 120/240-volt dc PV system would have to be rated at 240 volts. The inherent differences between a dc current source (PV modules) and a voltage source (ac grid) bear on this issue. Even the definitions of circuit voltage in the *NEC* and *NEC Handbook* refer to ac and dc systems, but do not take into account the design of the balance of systems required in current-limited PV systems. In a PV system, all wiring, disconnects, and overcurrent devices have current ratings that exceed the short-circuit currents by at least 25%. In the case of bolted faults or ground faults involving currents from the PV array, the overcurrent devices do not trip because they are rated to withstand continuous operation at levels above the fault levels. In an ac system, bolted faults and ground faults generally cause the overcurrent devices to trip or blow removing the source of voltage from the fault. Therefore, the faults that pose high-voltage problems in PV, dc systems cause the voltage to be removed in ac, grid-supply systems. For these reasons, a switch rated at 120 volts can be used in an ac system with voltages up to 240 volts, but in a dc, PV system, the switch would have to be rated at 240 volts.

Another consideration that we are dealing with is the analogy of dc supply circuit and ac load circuits. An analysis of ac supply circuits would be similar to dc supply circuits.

Underwriters Laboratories (UL) Standard 1703 requires that manufacturers of modules listed to the standard include, in the installation instructions, a statement that the open-circuit voltage should be multiplied by 125% (crystalline cells), further increasing the voltage requirement of the balance-of-systems (BOS) equipment. This requirement has been in the *NEC* Section 690.7 as a temperature-dependent constant since the 1999 edition of the Code.

Current PV modules that are listed to the *UL Standard 1703* are listed with a maximum system voltage of 600 volts. A few are listed to 1000 volts to meet European standards. Engineers caution all installers, factory and otherwise, to not exceed this voltage. This restriction is not modified by the fact that the modules undergo high-pot tests at higher voltages.

Although not explicitly stated by the *NEC*, it is evident that the intent of the Code and the *UL Standards* is that all cable, switches, fuses, circuit breakers, and modules in a PV system be rated for the maximum system voltage. This is clarified in the 1999 *NEC* [690.7(A)].

While reducing the potential for line-to-line faults, the practice of wiring each monopole (one of two electrical source circuits) in a separate conduit to the inverter does not eliminate the problem. Consider the bipolar system presented in Figure D-1 with a bolted fault (or deliberate short) from the negative to the positive array conductor at the input of the inverter. With the switches closed, array short-circuit current flows, and neither fuse opens.

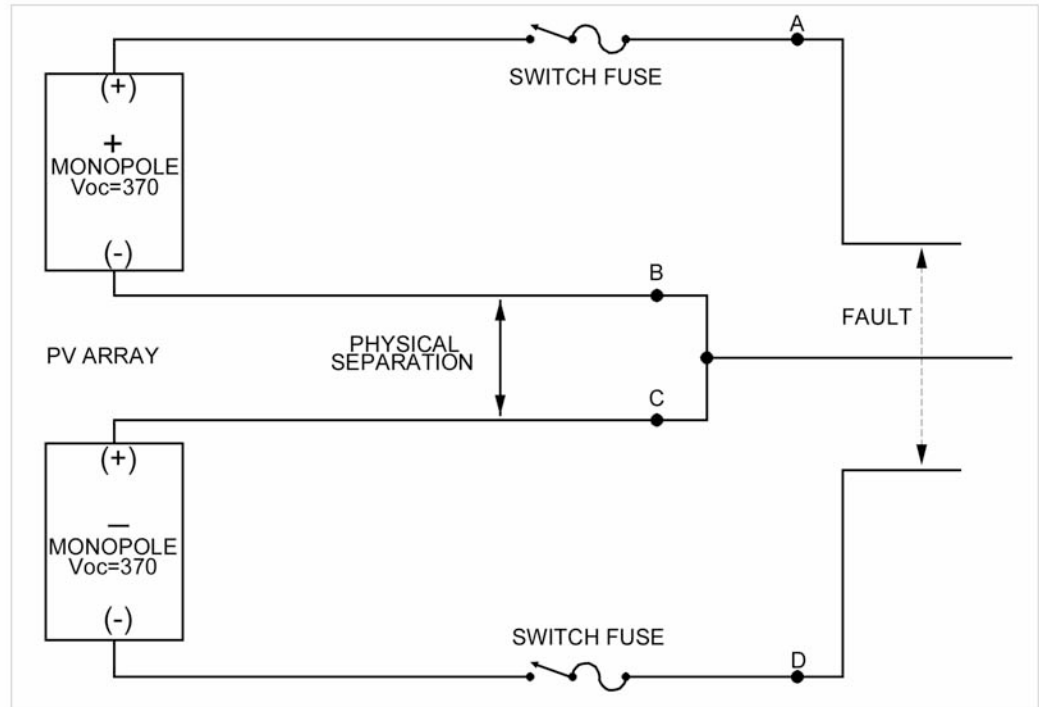

Figure D-1. Typical Bipolar System with Fault

Now consider what happens in any of the following cases.

1. A switch is opened
2. A fuse opens
3. A wire comes loose in a module junction box
4. An intercell connection opens or develops high resistance
5. A conductor fails at any point

In any of these cases, the entire array voltage (740 volts) stresses the device where the circuit opens. This voltage (somewhere between zero at short-circuit and the array open-circuit voltage) will appear at the device or cable. As the device starts to fail, the current through it goes from I_{sc} to zero as the voltage across the device goes from zero to V_{oc} . This process is very conducive to sustained arcs and heating damage.

Separating the monopoles does not avoid the high-voltage stress on any component, but it does help to minimize the potential for some faults. There are other possibilities for faults that will also place the same total voltage on various components in the system. An improperly installed grounding conductor coupled with a module ground fault could result in similar problems.

Section 690.5 of the *NEC* requires a ground-fault device on PV systems that are installed on the roofs of dwellings. This device, used for fire protection, **must** detect the fault, interrupt the fault current, indicate the fault, and disconnect the array.

Some large (100 kW) utility-interactive PV systems like the one at Juana Diaz, Puerto Rico have inverters that, when shut down, crowbar the array. The array remains crowbarred until the ac power is shut off and creates a similar fault to the one pictured in Figure D-1.

NEC VOLTAGE LIMITATION

The second issue associated with this concern is that the *NEC* in Section 690.7(C) only allows PV installations up to 600 volts in one and two-family dwellings. Inverter and system design issues may favor higher system voltage levels.

VOLTAGE REMEDIES

System designers can select inverters with lower operating and open-circuit voltages. Utility-intertie inverters are available with dc input voltages as low as 24 volts. The system designer also can work with the manufacturers of higher voltage inverters to reduce the number of modules in each series string to the point where the cold-temperature open-circuit voltage is less than 600 volts. The peak-power voltage would also be lowered. Transformers may be needed to raise the inverter ac output voltage to the required level. All utility-interactive inverters listed in the US operate with PV arrays that have open-circuit voltages of less than 600 volts.

Cable manufacturers produce UL-Listed, cross-linked polyethylene, single-conductor cable. It is marked USE-2/RHW-2, Sunlight Resistant and is rated at 2000 volts. This cable could be used for module interconnections in conduit after all of the other *NEC* requirements are met for installations above 600 volts.

Several manufacturers issue factory certified rating on their three-pole disconnects to allow higher voltage, non-load break operation with series-connected poles. The *NEC* will require an acceptable method of obtaining non-load break operation.

Some OEM circuit breaker manufacturers will factory certify series-connected poles on their circuit breakers. Units have been used at 750 volts and 100 amps with 10,000 amps of interrupt rating. Higher voltages may be available.

High-voltage industrial fuses are available, but dc ratings are unknown at this time.

Individual 600-volt terminal blocks can be used with the proper spacing for higher voltages.

Module manufacturers can have their modules listed for higher system voltages. Most are currently limited to 600 volts.

Power diodes may be connected across each monopole. When a bolted line-to-line fault occurs, one of the diodes will be forward biased when a switch or fuse

opens, thereby preventing the voltage from one monopole from adding to that of the other monopole. The diodes are mounted across points A-B and C-D in Figure D-1. Each diode should be rated for at least the system open-circuit voltage and the full short-circuit current from one monopole. Since diodes are not listed as over-voltage protection devices, this solution is not recognized in the *NEC*.

The *NEC* allows PV installations over 600 volts in non-residential applications, which will cover the voltage range being used in most current designs.

It should be noted that there are numerous requirements throughout the *NEC* that apply specifically to installations over 600 volts:

- All equipment **must** be listed for the maximum voltage.
- Clearance distances and mechanisms for achieving that clearance are significantly more stringent as voltages increase above 600 volts.

Section 690.7(E) allows specially configured and listed inverters to be used in a system where the voltages are measured line-to-ground rather than line.

APPENDIX E: Example Systems

The systems described in this appendix and the calculations shown are presented as examples only. The calculations for conductor sizes and the ratings of overcurrent devices are based on the requirements of the *National Electrical Code (NEC)* and on *UL Standard 1703* which provides instructions for the installation of UL-Listed PV modules. Local codes and site-specific variations in irradiance, temperature, and module mounting, as well as other installation particularities, dictate that these examples should not be used without further refinement. Tables 310.16 and 310.17 from the *NEC* provide the ampacity data and temperature derating factors.

CABLE SIZING AND OVERCURRENT PROTECTION

The procedure presented below for cable sizing and overcurrent protection of that cable is based on *NEC* requirements in Sections 690.9, 690.8, 110.14(C), 210.20(A), 215.2, 215.3, 220.10, 240.3(B), and 240.6(A). See Appendix I for a slightly different method of making ampacity calculations based on the same requirements.

- 1. Circuit Current.** For circuits carrying currents from PV modules, multiply the short-circuit current by 125% and use this value for all further calculations. For PV circuits in the following examples, this is called the CONTINUOUS CURRENT calculation. In the Code, this requirement has been included in Section 690.8, but also remains in UL 1703. This multiplier should not be applied twice.

For dc and ac inverter circuits in PV systems, use the rated continuous currents. These currents are continuous by definition and are not multiplied by 125% at this step.

AC and dc load circuits should follow the requirements of Sections 210, 220, and 215.

- 2. Overcurrent Device Rating.** The overcurrent device **must** be rated at 125% of the current determined in Step 1. This is to prevent overcurrent devices from being operated at more than 80% of rating. This calculation, in the following examples, is called the 80% OPERATION.

If the overcurrent device is operating in ambient temperatures above 40°C, the rating of the device must be adjusted based on data obtained from the manufacturer. See Step 7.

- 3. Cable Sizing.** Cables **shall** have a 30°C ampacity of 125% of the continuous current determined in Step 1 to ensure proper operation of connected overcurrent devices. There are no additional deratings applied with this calculation.

4. **Cable Derating.** Based on the determination of Step 3 and the location of the cable (raceway or free-air), a cable size and insulation temperature rating (60, 75, or 90°C) are selected from the *NEC* Ampacity Tables 310.16 or 310.17. Use the 75°C (a short-cut) cable ampacities to get the size, then use the ampacity from the 90°C column—if needed—for the deratings. This cable is then derated for temperature, conduit fill, and other requirements. The resulting derated ampacity **must** be greater than the value found in Step 1. No 125% multiplier is used for this determination. If not greater, then a larger cable size or higher insulation temperature **must** be selected. The current in Step 3 is not used at this point to preclude over sizing the cables.
5. **Ampacity vs. Overcurrent Device.** The derated ampacity of the cable selected in Step 4 **must** be equal to or greater than the overcurrent device rating determined in Step 2 [240.4]. If the derated ampacity of the cable is less than the rating of the overcurrent device, then a larger cable **must** be selected. The next larger standard size overcurrent device may be used if the derated cable ampacity falls between the standard overcurrent device sizes found in *NEC* Section 240.6.

Note: This step may result in a larger conductor size than that determined in Step 4.

6. **Device Terminal Compatibility.** Since most overcurrent devices have terminals rated for use at a maximum temperature of 75°C (or 60°C), compatibility **must** be verified [110.3(B)]. If a 90°C-insulated cable was selected in the above process, the 30°C current of the same size cable with a 75°C (or 60°C) insulation **must** be greater than or equal to the current found in Step 2, 125% of the continuous current [110.14(C)]. *NEC* Table 310.16 is always used for this determination. This ensures that the cable will operate at temperatures below the temperature rating of the terminals of the overcurrent device. If the overcurrent device is located in an area with ambient temperature higher than 30°C, then the 75°C (or 60°C) current used to determine the maximum allowable current for that size wire **must** also be derated by the temperature correction factors at the bottom of the 75°C (or 60°C) column [110.3(B)].
7. If the overcurrent device is mounted in a location that has an ambient temperature higher than 40°C (for example, in a PV combiner box), then the rating of the device must be adjusted per manufacturer's specifications with an increased rating. Verify that the OCPD still protects the selected cable under conditions of use.

Here is an example of how the procedure is used:

The task is to size and protect two PV source circuits in conduit, each with an $I_{sc} = 40$ amps. Four current-carrying conductors are in the conduit and are operating in

a 45°C ambient temperature. Conductors with a 90°C insulation are going to be used. The fuse is also in an ambient temperature of 40°C.

Step 1: $1.25 \times 40 = 50$ amps. (continuous current)

Step 2: The required fuse (with 75°C terminals) is $1.25 \times 50 = 62.5$ amps. The next standard fuse size is 70 amps. (ensures operation below 80% of rating). The fuse is operating in an ambient temperature of 40°C, so no additional derating of the fuse rating is required.

Step 3: Same calculation as Step 2. Cable ampacity without deratings must be 62.5 amps.

Step 4: From Table 310.16, cables with 75°C insulation: A 6 AWG conductor at 65 amps is needed. This meets Step 3 requirements. At least a 6 AWG XHHW-2 cable with 90°C insulation and a 30°C ampacity of 75 amps should be installed. Conduit fill derating is 0.8 and temperature derating is 0.87. Derated ampacity is 52.2 amps ($75 \times 0.8 \times 0.87$). This is greater than the required 50 amps in Step 1 and meets the requirement.

Step 5: It is acceptable to protect a cable with a derated ampacity of 52.2 amps with a 60-amp overcurrent device since this is the next larger standard size. However, this circuit requires at least a 62.5 amp device (Step 2). Therefore, the conductor **must** be increased to a 4 AWG conductor with a derated ampacity of 66 amps ($95 \times 0.87 \times 0.8$). A 70-amp fuse or circuit breaker is acceptable to protect this cable since it is the next larger standard size.

Step 6. The ampacity of a 4 AWG cable with 75°C insulation (because the fuse has 75°C terminals) operating at 45°C is 70 amps ($85 \times .82$), and is higher than the calculated 125% of the continuous circuit current of 62.5 amps found in Step 2. Using the 75°C column in Table 310.16 or 310.17 for starting Step 4 usually, but not always ensures that this check will be passed. However, such a shortcut may result in a conductor larger than necessary.

EXAMPLES

EXAMPLE 1 Direct-Connected Water Pumping System

Array Size: 4, 12-volt, 60-watt modules; $I_{sc} = 3.8$ amps, $V_{oc} = 21.1$ volts

Load: 12-volt, 10-amp motor

Description

The modules are mounted on a tracker and connected in parallel. The modules are wired as shown in Figure E-1 with 10 AWG USE-2 single-conductor cable. A loop is placed in the cable to allow for tracker motion without straining the rather stiff building cable. The USE-2 cable is run to a disconnect switch in an enclosure

mounted on the pole. From this disconnect enclosure, 8 AWG XHHW-2 cable in electrical nonmetallic conduit is routed to the wellhead. The conduit is buried 18 inches deep. The 8 AWG cable is used to minimize voltage drop.

The *NEC* requires the disconnect switch. Because the PV modules are current limited and all conductors have an ampacity greater than the maximum output of the PV modules, no overcurrent device is required, although some inspectors might require it and it might serve to provide some degree of lightning protection. A dc-rated disconnect switch or a dc-rated fused disconnect **must** be used. Since the system is ungrounded, a two-pole switch **must** be used. All module frames, the pole, the disconnect enclosure, and the pump housing **must** be grounded with equipment-grounding conductors, whether the system is grounded or not.

The fuses shown connected to each module are required to protect the module from reverse currents from all sources. In this system, the only sources of potential reverse currents for an individual module are the modules connected in parallel. Those other three (out of four modules) could source $3 \times 3.8 \times 1.25 = 14.25$ amps of current into a fault in a single module. If the module series protective fuse were 15 amps or less, these fuses would not be required; the potential currents could not damage any module. Of course, the conductors to each module should also have an ampacity of 15 amps or greater if the fuses were omitted. The 10 AWG USE-2 cable meets this requirement.

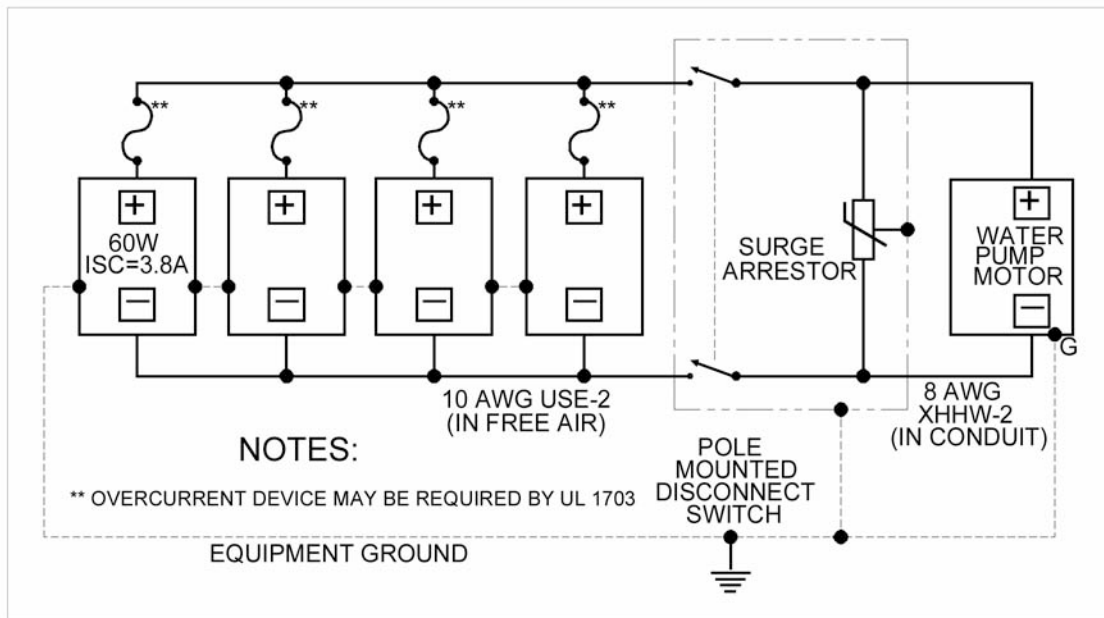

Figure E-1. Direct Connected System

Calculations

The array short-circuit current is 15.2 amps (4×3.8).

CONTINUOUS CURRENT: $1.25 \times 15.2 = 19$ amps (Step 1)

No fuse, no Step 2

80% OPERATION: $1.25 \times 19 = 23.75$ amps (Step 3)

The ampacity of 10 AWG USE-2 at 30°C is 55 amps.

The ampacity at 61-70°C is 31.9 amps (0.58×55) which is more than the 19 amp requirement. (Step 4)

The equipment grounding conductors should be 10 AWG (typically 1.25 I_{sc} with a 14 AWG minimum).

The minimum voltage rating of all components is 26 volts (1.25×21.1).

EXAMPLE 2 Water Pumping System with Current Booster

Array Size: 10, 12-volt, 53-watt modules; $I_{sc} = 3.4$ amps, $V_{oc} = 21.7$ volts
Current Booster Output: 90 amps
Load: 12-volt, 40-amp motor

Description

This system has a current booster before the water pump and has more modules than in Example 1. Initially, 8 AWG USE-2 cable was chosen for the array connections, but a smaller cable was chosen to attach to the module terminals. As the calculations below show, the array was split into two subarrays. There is potential for malfunction in the current booster, but it does not seem possible that excess current can be fed back into the array wiring, since there is no other source of energy in the system. Therefore, these conductors do not need overcurrent devices if they are sized for the entire array current. If smaller conductors are used, then overcurrent devices will be needed.

However, there are now 10 modules in parallel connected via the two 30-amp circuit breakers. The potential reverse current from 9 modules would be $9 \times 3.4 \times 1.25 = 38.25$ amps. This is well in excess of the ability of the module to handle reverse currents (possibly as low as 10 amps), so a fuse or circuit breaker must be used in series with each module. The minimum value would be 1.56×3.4 amps = 5.3 amps and the next higher standard value is 6 amps. These fuses would normally be contained in a PV combiner mounted in the shade behind the PV array.

Since the array is broken into two subarrays, the maximum short-circuit current available in either subarray wiring is equal to the subarray short-circuit current under fault conditions plus any current coming back through one of the 30-amp breakers from the other subarray. Overcurrent devices are needed to protect the subarray conductors under these conditions.

A grounded system is selected, and only single-pole disconnects are required. Equipment grounding and system grounding conductors are shown in Figure E-2

If the current booster output conductors are sized to carry the maximum current (3-hour) of the booster, then overcurrent devices are not necessary, but again, some inspectors may require them.

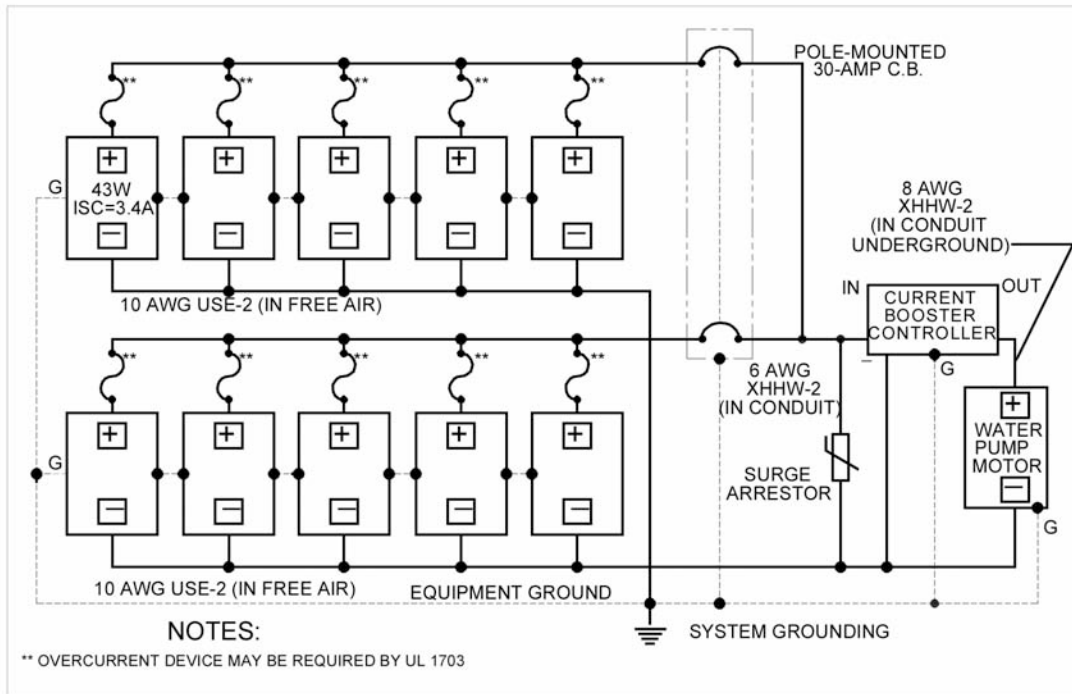

Figure E-2. Direct-Connected PV System with Current Booster

Calculations

The entire array short-circuit current is 34 amps (10 x 3.4).

CONTINUOUS CURRENT: $1.25 \times 34 = 42.5$ amps

80% OPERATION: $1.25 \times 42.5 = 53.1$ amps

The ampacity of 6 AWG USE-2 cable at 30°C in conduit is 75 amps.

The ampacity at 45°C (maximum ambient air temperature) is 65.5 amps (0.87×75), which is greater than the 42.5 amp requirement; so a single array could have been used. However, the array is split into two subarrays for serviceability. Each is wired with 10 AWG USE-2 conductors.

The subarray short-circuit current is 17 amps (5 x 3.4).

CONTINUOUS CURRENT: $1.25 \times 17 = 21.3$ amps

80% OPERATION: $1.25 \times 21.25 = 26.6$ amps

The ampacity of 10 AWG USE-2 at 30°C in free air is 55 amps.

The ampacity at 61-70°C (module operating temperature) is 31.9 amps (0.58×55), which is more than the 21.3 amp requirement. Since this cable is to be connected to an overcurrent device with terminals rated at 60°C or 75°C, the ampacity of the cable **must** be evaluated with 60°C or 75°C insulation. Overcurrent devices rated at 100 amps or less may have terminals rated at only 60°C. The ampacity of 10 AWG 75°C cable operating at 30°C is 35 amps, which

is more than the 26.6 amps requirement. Therefore, there are no problems with the terminals on a 75°C overcurrent device.

Thirty-amp circuit breakers are used to protect the 10 AWG subarray conductors. The required rating is $1.25 \times 21.25 = 26.6$ amps, and the next largest size is 30 amps. Note: The maximum allowed overcurrent device for a 10AWG conductor is 30 amps [240.4(D)].

The current booster maximum current is 90 amps.

The current booster average long-term (3-hours or longer) current is 40 amps (continuous current).

80% OPERATION: $1.25 \times 40 = 50$ amps

The ampacity of 8 AWG XHHW-2 at 30°C in conduit is 55 amps.

The ampacity does not need temperature correction since the conduit is buried in the ground. The ampacity requirements are met, but the cable size may not meet the overcurrent device connection requirements when an overcurrent device is used.

The 6 AWG conductors are connected to the output of the circuit breakers, and there is a possibility that heating of the breaker may occur. It is therefore good practice to make the calculation for terminal overheating. The ampacity of a 6 AWG conductor evaluated with 75°C insulation (the rated maximum temperature of the terminals on the overcurrent device) is 65 amps, which is greater than the 27-amp requirement. This means that the overcurrent device will not be subjected to overheating when the 6 AWG conductor carries 27 amps.

All equipment-grounding conductors should be 10 AWG. The grounding electrode conductor should be 8 AWG or larger.

Minimum voltage rating of all components: $1.25 \times 21.7 = 27$ volts

EXAMPLE 3 Stand-Alone Lighting System

Array Size: 4, 12-volt, 64-watt modules; $I_{sc} = 4.0$ amps, $V_{oc} = 21.3$ volts

Batteries: 200-amp-hours at 24 volts

Load: 60 watts at 24 volts

Description

The modules are mounted at the top of a 20-foot pole with the metal-halide lamp. The modules are connected in series and parallel to achieve the 24-volt system rating. The lamp, with an electronic ballast and timer/controller, draws 60 watts at 24 volts. The batteries, disconnect switches, charge controller, and overcurrent devices are mounted in a box at the bottom of the pole. The system is grounded as shown in Figure E-3.

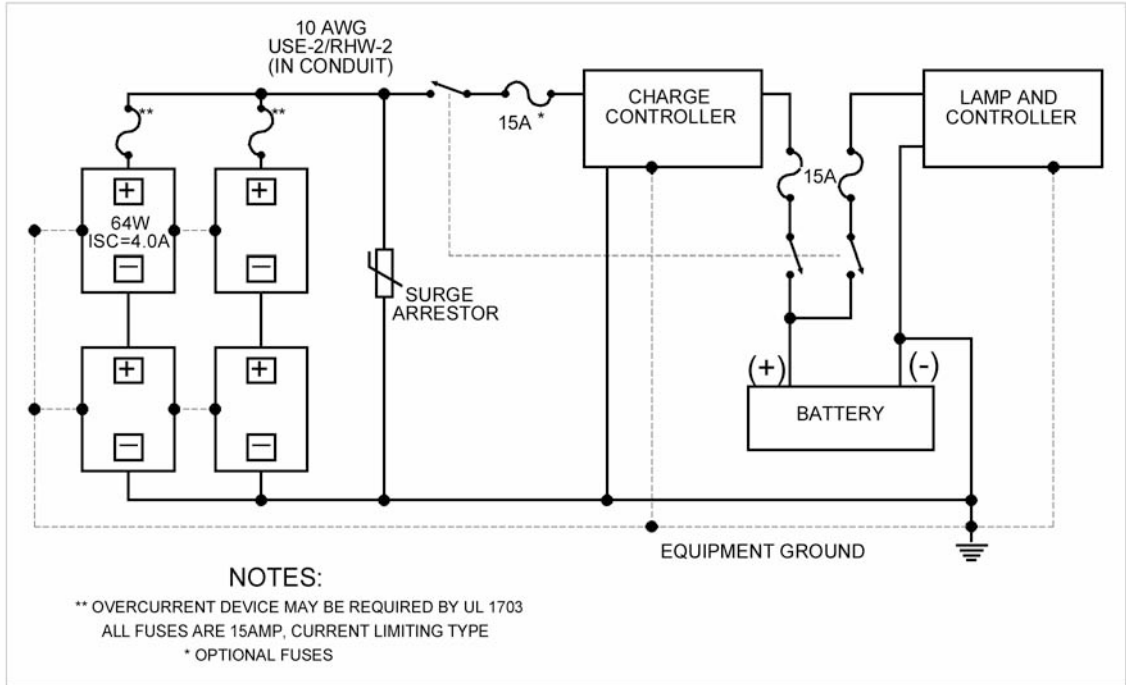

Figure E-3. Stand-Alone Lighting System

Calculations:

- The array short-circuit current is 8 amps (2 x 4).
- CONTINUOUS CURRENT: $1.25 \times 8 = 10$ amps
- 80% OPERATION: $1.25 \times 10 = 12.5$ amps
- Load Current: $60/24 = 2.5$ amps (continuous)
- 80% OPERATION: $1.25 \times 2.5 = 3.1$ amps

Cable size 10 AWG USE-2/RHW-2 is selected for module interconnections and is placed in conduit at the modules and then run down the inside of the pole.

The modules operate at 61-70°C, which requires that the module cables be temperature derated. Cable 10 AWG USE-2/RHW-2 has an ampacity of 40 amps at 30°C in conduit. The derating factor is 0.58. The temperature-derated ampacity is 23.2 amps (40 x 0.58), which exceeds the 10-amp requirement. Checking the cable with a 75°C insulation, the ampacity at the fuse end is 35 amps, which exceeds the 12.5-amp requirement. This cable can be protected by a 15-amp fuse or circuit breaker (125% of 10 is 12.5). An overcurrent device rated at 100 amps or less may only have terminals rated for 60°C, not the 75°C used in this example. Lower temperature calculations may be necessary.

The same USE-2/RHW-2, 10 AWG cable is selected for all other system wiring, because it has the necessary ampacity for each circuit.

A three-pole fused disconnect is selected to provide the PV and load disconnect functions and the necessary overcurrent protection. The fuse selected is a RK-5

type, providing current limiting in the battery circuits. A pullout fuse holder with either Class RK-5 or Class T fuses could also be used for a more compact installation. Fifteen-amp fuses are selected to provide overcurrent protection for the 10 AWG cables. They are used in the load circuit and will not blow on any starting surges drawn by the lamp or controller. The 15-amp fuse before the charge controller could be eliminated since that circuit is protected by the fuse on the battery side of the charge controller. The disconnect switch at this location is required.

One of the two strings of PV modules could be subjected to reverse currents from the other string ($1.25 \times 4 = 5$ amps) plus 15 amps from the battery through the 15-amp fuse. If this 20-amp potential backfed current exceeds the module series fuse requirement, then the string fuses and a PV combiner must be added to the system.

The equipment-grounding conductors should be 10 AWG conductors. An 8 AWG (minimum) conductor would be needed to the ground rod.

The dc voltage ratings for all components used in this system should be at least 53 volts ($2 \times 21.3 \times 1.25$).



EXAMPLE 4 Remote Cabin DC-Only System

Array Size: 6, 12-volt, 75-watt modules; $I_{sc} = 4.8$ amps, $V_{oc} = 22$ volts

Batteries: 700 amp hours at 12 volts

Load: 75 watts peak at 12-volts dc

Description

The modules are mounted on a rack on a hill behind the house. Nonmetallic conduit is used to run the cables from the junction box to the control panel. A control panel is mounted on the back porch, and the batteries are in an insulated box under the porch. All the loads are dc with a peak-combined power of 75 watts at 12 volts due, primarily, to a pressure pump on the gravity-fed water supply. The battery bank consists of four 350-amp-hour, 6-volt, deep-cycle batteries wired in series and parallel. Figure E-4 shows the system schematic.

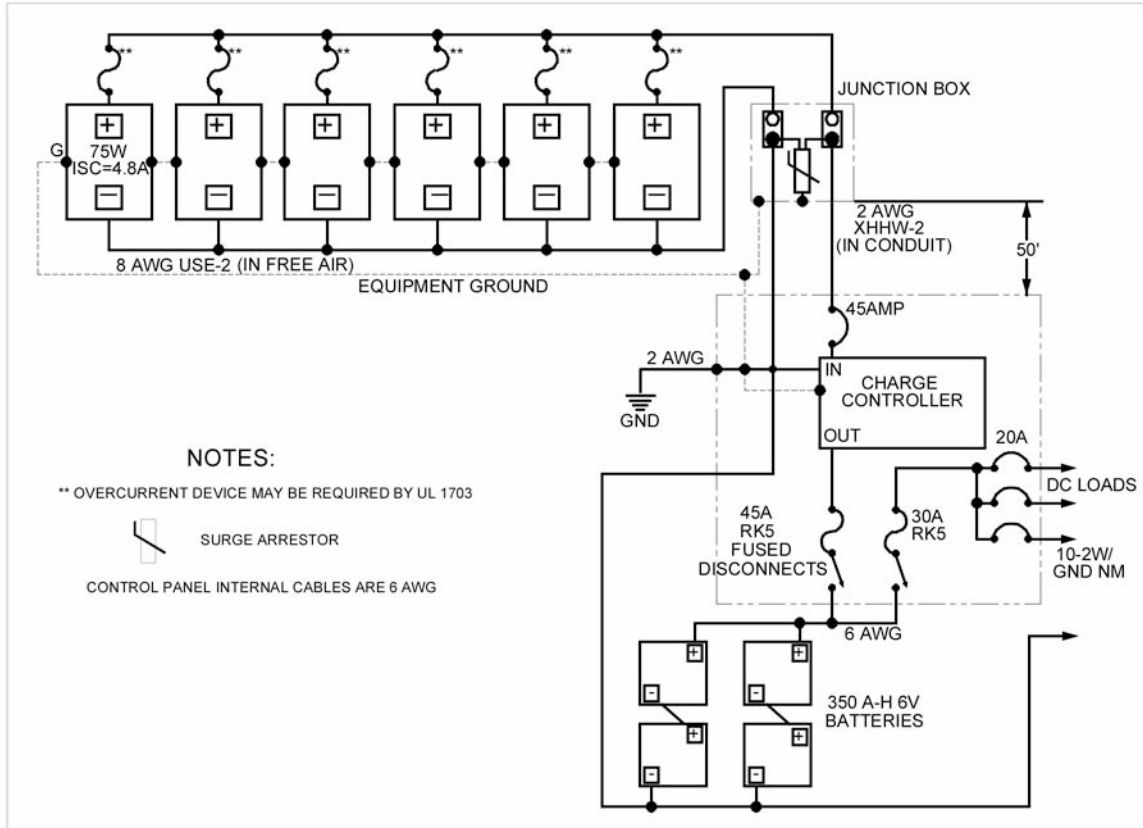

Figure E-4. Remote Cabin DC-Only System

Calculations

The array short-circuit current is 28.8 amps (6 x 4.8).

CONTINUOUS CURRENT: $1.25 \times 28.8 = 36$ amps

80% OPERATION: $1.25 \times 36.0 = 45$ amps

The module interconnect wiring and the wiring to a rack-mounted junction box will operate at 65°C. If USE-2 cable with 90°C insulation is chosen, then the temperature derating factor will be 0.58. The required ampacity of the cable at 30°C is 62 amps ($36/0.58$), which can be handled by 8 AWG cable with an ampacity of 80 amps in free air at 30°C. Conversely, the ampacity of the 8 AWG cable is 46.4 amps (80×0.58) at 65°C which exceeds the 36 amp requirement.

A PV combiner with a fuse for each module will be required because the available potential short-circuit current from these six modules in parallel plus the 45-amps from the PV disconnect circuit breaker will far exceed the maximum reverse current rating of a module.

From the rack-mounted junction box to the control panel, the conductors will be in conduit and exposed to 40°C temperatures. If XHHW-2 cable with a 90°C insulation is selected, the temperature derating factor is 0.91. The required ampacity of the cable at 30°C would be $36/0.91 = 39.6$ amps in conduit. Cable

size 8 AWG has an ampacity of 55 amps at 30°C in conduit. Conversely, the 8 AWG conductor has an ampacity of 50 amps (55×0.91) at 40°C in conduit that exceeds the 39.6 amp requirement at this temperature.

The 8 AWG cable, evaluated with a 75°C insulation, has an ampacity at 30°C of 50 amps, which is greater than the 45 amps that might heat the fuse terminals.

The array is mounted 200 feet from the house, and the round trip cable length is 400 feet. A calculation of the voltage drop in 400 feet of 8 AWG cable operating at 36 amps ($125\% I_{sc}$) is $0.778 \text{ ohms per } 1000 \text{ feet} \times 400 / 1000 \times 36 = 11.2 \text{ volts}$. This represents an excessive voltage drop on a 12-volt system, and the batteries cannot be effectively charged. Conductor size 2 AWG (with a voltage drop of 2.8 volts) was substituted; this substitution is acceptable for this installation. The conductor resistances are taken from Table 8 in Chapter 9 of the *NEC* and are given for conductors at 75°C.

The PV conductors are protected with a 45-amp (1.25×36) single-pole circuit breaker on this grounded system. The circuit breaker should be rated to accept 2 AWG conductors and have terminals rated for use with 75°C-insulated conductors.

Cable size 6 AWG THHN cable is used in the control center and has an ampacity of 65 amps at 30°C when evaluated with 75°C insulation. Wire size 2 AWG from the negative dc input is used to the point where the grounding electrode conductor is attached instead of the 6 AWG conductor used elsewhere to comply with grounding requirements.

The 75-watt peak load draws about 6.25 amps and 10-2 with ground (w/gnd) nonmetallic sheathed cable (type NM) was used to wire the cabin for the pump and a few lights. DC-rated circuit breakers rated at 20 amps were used to protect the load wiring, which is in excess of the peak load current of 7.8 amps (1.25×6.25) and less than the cable ampacity of 30 amps.

Current-limiting fuses in a fused disconnect are used to protect the dc-rated circuit breakers, which may not have an interrupt rating sufficient to withstand the short-circuit currents from the battery under fault conditions. RK-5 fuses were chosen with a 45-amp rating in the charge circuit and a 30-amp rating in the load circuit. The fused disconnect also provides a disconnect for the battery from the charge controller and the dc load center.

The equipment grounding conductors should be 10 AWG and the grounding electrode conductor should be 2 AWG. A smaller grounding electrode conductor (as small as 8 AWG) may be acceptable to the local inspector.

All components should have a voltage rating of at least $1.25 \times 22 = 27.5 \text{ volts}$.

EXAMPLE 5 Small Residential Stand-Alone System

Array Size: 10, 12-volt, 51-watt modules; $I_{sc} = 3.25$ amps, $V_{oc} = 20.7$ volts

Batteries: 800 amp-hours at 12 volts

Loads: 5 amps dc and 500-watt inverter with 90% efficiency

Description

The PV modules are mounted on the roof. Single-conductor cables are used to connect the modules to a roof-mounted junction box. Potential reverse fault currents indicate that a PV combiner be used with a series fuse for each PV module. UF two-conductor sheathed cable is used from the roof to the control center. Physical protection (wood barriers or conduit) for the UF cable is used where required. The control center, diagrammed in Figure E-5, contains disconnect and overcurrent devices for the PV array, the batteries, the inverter, and the charge-controller.

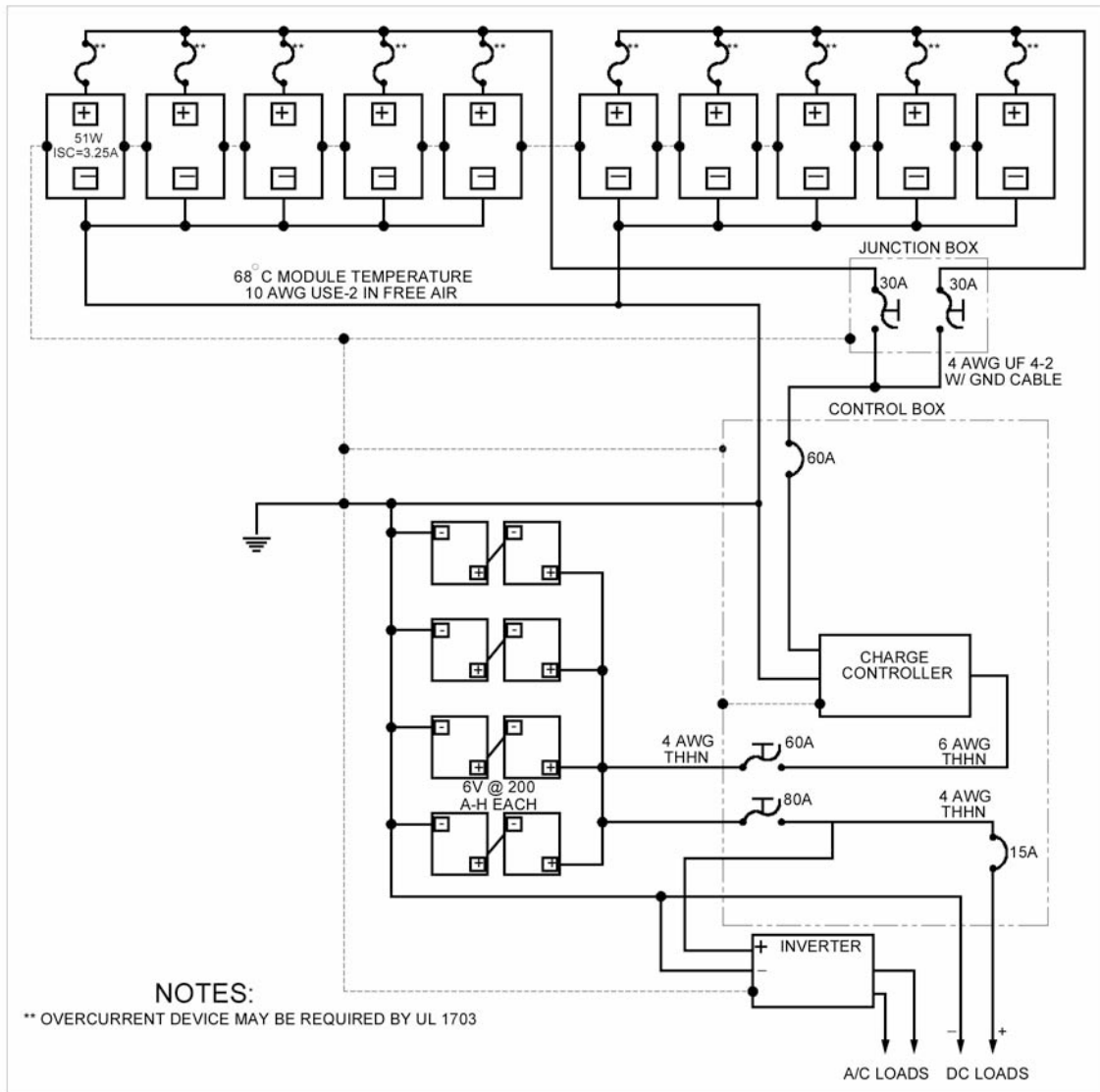

Figure E-5. Small Residential Stand-Alone System

Calculations

The module short-circuit current is 3.25 amps.

CONTINUOUS CURRENT: $1.25 \times 3.25 = 4.06$ amps

80% OPERATION: $1.25 \times 4.06 = 5.08$ amps per module

The maximum estimated module operating temperature is 68°C.

From *NEC* Table 310.17:

The derating factor for USE-2 cable is 0.58 at 61-70°C.

Cable 14 AWG has an ampacity at 68°C of 20.3 amps (0.58×35) (max fuse is 15 amps—see notes at bottom of Tables 310-16 & 17).

Cable 12 AWG has an ampacity at 68°C of 23.2 amps (0.58×40) (max fuse is 20 amps).

Cable 10 AWG has an ampacity at 68°C of 31.9 amps (0.58×55) (max fuse is 30 amps).

Cable 8 AWG has an ampacity at 68°C of 46.4 amps (0.58×80).

The array is divided into two five-module subarrays. The modules in each subarray are wired from module junction box to the PV combiner for that subarray and then to the array junction box. Cable size 10 AWG USE-2 is selected for this wiring, because it has an ampacity of 31.9 amps under these conditions, and the requirement for each subarray is $5 \times 4.06 = 20.3$ amps. Evaluated with 75°C insulation, a 10 AWG cable has an ampacity of 35 amps at 30°C, which is greater than the actual requirement of 20.3 amps (5×4.06) [Table 310.16 must be used]. In the array junction box on the roof, two 30-amp fuses in pullout holders are used to provide overcurrent protection for the 10 AWG conductors. These fuses meet the requirement of 25.4 amps (125% of 20.3) and have a rating less than the derated cable ampacity.

In this junction box, the two subarrays are combined into an array output. The ampacity requirement is 40.6 amps (10×4.06). A 4 AWG UF cable (4-2 w/gnd) is selected for the run to the control box. It operates in an ambient temperature of 40°C and has a temperature-corrected ampacity of 86 amps (95×0.91). This is a 60°C cable with 90°C conductors and the final ampacity must be restricted to the 60°C value of 70 amps, which is suitable in this example. Appropriately derated cables **must** be used when connecting to fuses that are rated for use only with 75°C conductors.

A 60-amp circuit breaker in the control box serves as the PV disconnect switch and overcurrent protection for the UF cable. The minimum rating would be $10 \times 3.25 \times 1.56 = 51$ amps. The *NEC* allows the next larger size; in this case, 60 amps, which will protect the 70 amp rated cable. Two single-pole, pullout fuse holders are used for the battery disconnect. The charge circuit fuse is a 60-amp RK-5 type.

The inverter has a continuous rating of 500 watts at the lowest operating voltage of 10.75 volts and an efficiency of 90% at this power level. The continuous current calculation for the input circuit is 64.6 amps $((500 / 10.75 / 0.90) \times 1.25)$.

The cables from the battery to the control center **must** meet the inverter requirements of 64.6 amps plus the dc load requirements of 6.25 amps (1.25×5) . A 4 AWG THHN has an ampacity of 85 amps when placed in conduit and evaluated with 75°C insulation. This exceeds the requirements of 71 amps $(64.6 + 6.25)$. This cable can be used in the custom power center and be run from the batteries to the inverter.

The discharge-circuit fuse **must** be rated at least 71 amps. An 80-amp fuse should be used, which is less than the cable ampacity.

The dc-load circuit is wired with 10 AWG NM cable (ampacity of 30 amps) and protected with a 15-amp circuit breaker.

The grounding electrode conductor is 4 AWG and is sized to match the largest conductor in the system, which is the array-to-control center wiring. This size would be appropriate for a concrete-encased grounding electrode.

Equipment-grounding conductors for the array and the charge circuit can be 10 AWG based on the 60-amp overcurrent devices. The equipment ground for the inverter **must** be an 8 AWG conductor based on the 80-amp overcurrent device. [Table 250.122]

All components should have at least a dc voltage rating of $1.25 \times 20.7 = 26$ volts.

EXAMPLE 6 Medium Sized Residential Hybrid System

Array Size: 40, 12-volt, 53-watt modules; $I_{sc} = 3.4$ amps, $V_{oc} = 21.7$ volts

Batteries: 1000 amp-hours at 24 volts

Generator: 6 kW, 240-volt ac

Loads: 15 amps dc and 4000-watt inverter, efficiency =.85

Description

The 40 modules (2120 watts STC rating) are mounted on the roof in five subarrays consisting of eight modules mounted on a single-axis tracker. The eight modules are wired in series and parallel for this 24-volt system. Five source circuits are routed to a custom power center. Single-conductor cables are used from the modules to roof-mounted PV combiners for each source circuit. The fuse for each series string of modules is rated at least 1.56 times the module I_{sc} , but less than or equal to the maximum module protective fuse marked on the back of the module. From the combiners, UF sheathed cable is run to the main power center.

Blocking diodes are not required or used to minimize voltage drops in the system.

A ground-fault protection device provides compliance with the requirements of *NEC* Section 690.5.

The charge controller is a relay type.

DC loads consist of a refrigerator, a freezer, several telephone devices, and two fluorescent lamps. The maximum combined current is 15 amps.

The 4000-watt sine-wave inverter supplies the rest of the house.

The 6-kW natural gas fueled, engine-driven generator provides back-up power and battery charging through the inverter. The 240-volt output of the generator is fed through a 5-kVA transformer to step it down to 120 volts for use in the inverter and the house. The transformer is protected on the primary winding by a 30-amp circuit breaker [450.3(B)]. Figure E-6 presents the details.

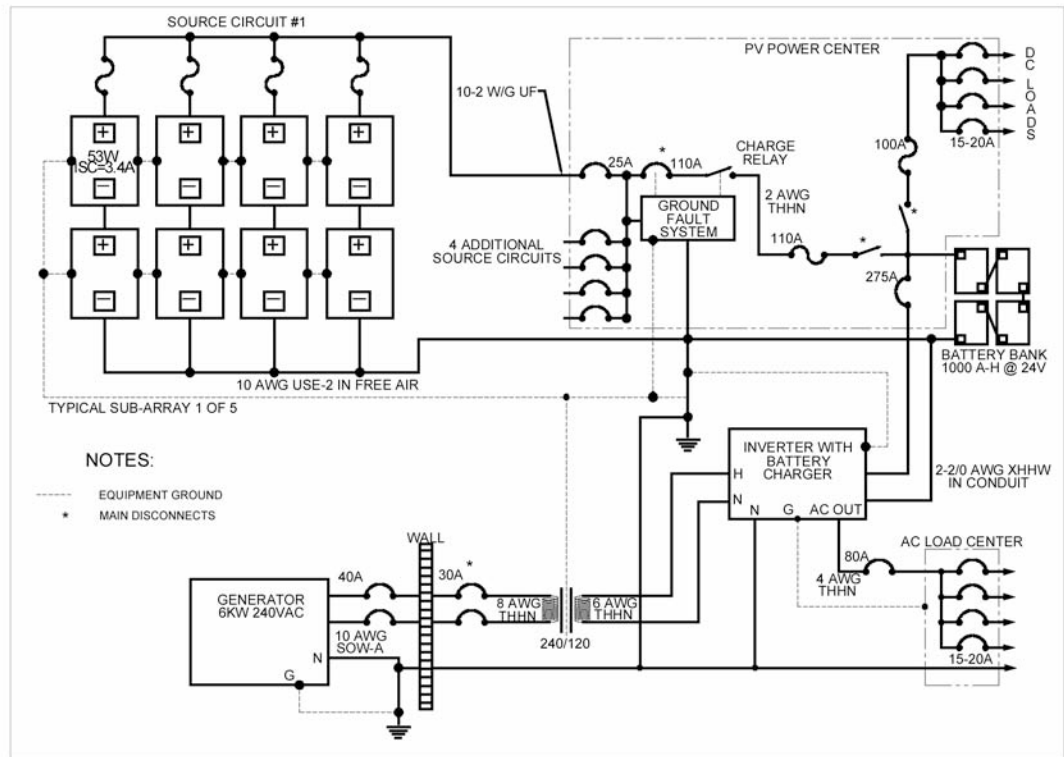

Figure E-6. Medium Sized Residential Hybrid System

Calculations

The subarray short-circuit current is 13.6 amps (4 x 3.4).

CONTINUOUS CURRENT: $1.25 \times 13.6 = 17$ amps

80% OPERATION: $1.25 \times 17 = 21.25$ amps

The temperature derating factor for USE-2 cable at 61-70°C is 0.58.

The ampacity of 10 AWG USE-2 cable at 70°C is 31.9 amps (55 x 0.58). [310.17]

The temperature derating factor for UF cable at 36-40°C is 0.91 for the 90°C conductors [310.16].

The ampacity of 10-2 w/gnd UF cable at 40°C is 36.4 amps (40 x 0.91), but is restricted to use with an overcurrent device of no more than 30 amps.

The source-circuit circuit breakers are rated at 25 amps (requirement is 125% of 17 amps = 21.25).

The PV array short-circuit current is 68 amps (5 x 13.6).

CONTINUOUS CURRENT: $1.25 \times 68 = 85$ amps

80% OPERATION: $1.25 \times 85 = 106$ amps

A 110-amp circuit breaker is used for the main PV disconnect after the five source circuits are combined.

A 110-amp RK5 current-limiting fuse is used in the charge circuit of the power center, which is wired with 2 AWG THHN conductors (115 amps with 75°C insulation).

The dc-load circuits are wired with 10-2 w/gnd NM cable (30 amps) and are protected with 20- or 30-amp circuit breakers. A 100-amp RK-5 fuse protects these breakers and the load circuits from excess current from the batteries.

Inverter

The inverter can produce 4000 watts ac at 22 volts with an efficiency of 85%.

The inverter input current ampacity requirements are 267 amps ($(4000 / 22 / 0.85) \times 1.25$). See Appendix F for more details.

Two 2/0 AWG USE-2 cables are paralleled in conduit between the inverter and the batteries. The ampacity of this cable (rated with 75°C insulation) at 30°C is 280 amps ($175 \times 2 \times 0.80$). The 0.80 derating factor is required because there are four current-carrying cables in the conduit.

A 275-amp circuit breaker with a 25,000-amp interrupt rating is used between the battery and the inverter. Current-limiting fusing is not required in this circuit.

The output of the inverter can deliver 4000 watts ac (33 amps) in the inverting mode. It can also pass up to 60 amps through the inverter from the generator while in the battery charging mode.

Ampacity requirements, ac output: $60 \times 1.25 = 75$ amps. This reflects the *NEC* requirement that circuits are not to be operated continuously at more than 80% of rating.

The inverter is connected to the ac load center with 4 AWG THHN conductors in conduit, which have an ampacity of 85 amps when used at 30°C with 75°C overcurrent devices. An 80-amp circuit breaker is used near the inverter to provide a disconnect function and the overcurrent protection for this cable.

Generator

The 6-kW, 120/240-volt generator has internal circuit breakers rated at 27 amps (6500-watt peak rating). The *NEC* requires that the output conductors between the generator and the first field-installed overcurrent device be rated at least 115% of the nameplate rating ($((6000 / 240) \times 1.15 = 28.75$ amps). Since the generator is connected through a receptacle outlet, a 10-4 AWG SOW-A portable cord (30 amps) is run to a NEMA 3R exterior circuit breaker housing. This circuit breaker is rated at 40 amps and provides overcurrent protection for the 8 AWG THHN conductors to the transformer. These conductors have an ampacity of 44 amps (50×0.88) at 40°C (75°C insulation rating). The circuit breaker also provides an exterior disconnect for the generator. Since the transformer isolates the generator conductors from the system electrical ground (separately derived system), the neutral of the generator is grounded at the exterior disconnect. The generator equipment-grounding conductors and grounding electrode conductor are bonded to the main system equipment-grounding conductors and the grounding electrode conductor.

A 30-amp circuit breaker is mounted near the PV Power Center in the ac line between the generator and the transformer. This circuit breaker serves as the interior ac disconnect for the generator and is grouped with the other disconnects in the system.

The output of the transformer is 120 volts. Using the rating of the generator, the ampacity of this cable **must** be 62.5 amps ($((6000 / 120) \times 1.25$). A 6 AWG THHN conductor was used, which has an ampacity of 65 amps at 30°C (75°C insulation rating).

Grounding

The module and dc-load equipment grounds **must** be 10 AWG conductors. Additional lightning protection will be afforded if a 6 AWG or larger conductor is run from the array frames to ground. The inverter equipment-grounding conductor **must** be a 4 AWG conductor based on the size of the overcurrent device for this circuit. [250.122] The grounding electrode conductor **must** be 2-2/0 AWG or a 500 kcmil conductor, unless there are no other conductors connected to the grounding electrode and that electrode is a ground rod; then this conductor may be reduced to 6 AWG [250.50].

DC Voltage Rating

All dc circuits should have a voltage rating of at least 55 volts ($1.25 \times 2 \times 22$).

EXAMPLE 7 Rooftop Utility-interactive System

Array Size: 24, 50-volt, 240-watt modules

$$I_{sc} = 5.6$$

$$V_{oc} = 62$$

Inverter: 200-volt nominal dc input
240-volt ac output at 5000 watts with an efficiency of 0.95.

Description

The rooftop array consists of six parallel-connected strings of four modules each. A PV combiner contains a fuse for each string of modules and a surge arrester. All wiring is RHW-2 in conduit. The inverter is located adjacent to the service entrance load center where PV power is fed to the grid through a back-fed circuit breaker. Figure E-7 shows the system diagram.

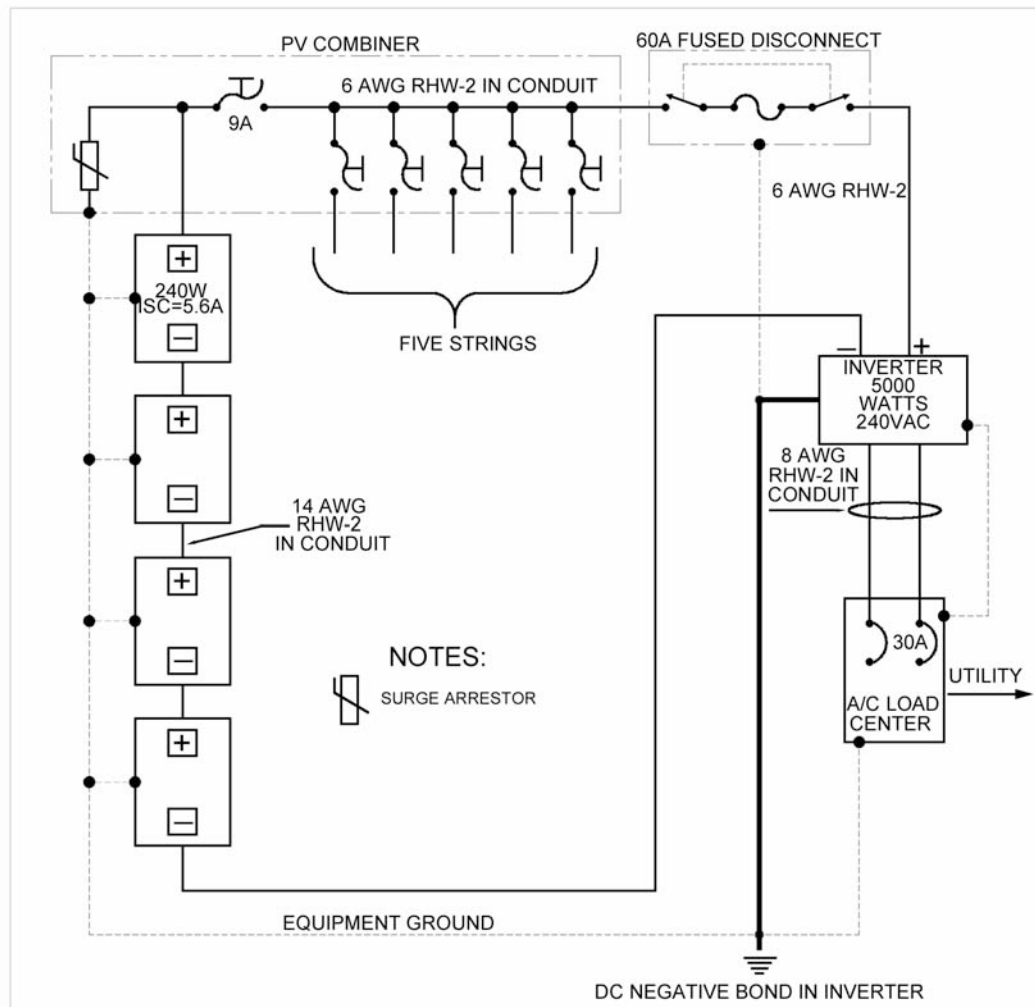

Figure E-7. Rooftop Utility-interactive System

Calculations

The string short-circuit current is 5.6 amps.

CONTINUOUS CURRENT: $1.25 \times 5.6 = 7$ amps

80% OPERATION: $1.27 \times 7 = 8.75$ amps

The array short-circuit current is 33.6 amps (6×5.6).

CONTINUOUS CURRENT: $1.25 \times 33.6 = 42$ amps

80% OPERATION: $1.25 \times 42 = 52.5$ amps

The modules in each string are connected in series. The modules and attached conductors operate at 63°C. The temperature-derating factor for RHW-2 at this temperature is 0.58. The required 30°C ampacity for this cable is 15 amps ($8.75 / 0.58$). RHW-2 14 AWG cable has an ampacity of 25 amps with 90°C insulation and 20 amps with 75°C insulation so there is no problem with the end of the cable connected to the fuse (with 75°C terminals) since the 7 amps is below either ampacity. Even with 60°C fuse terminals, the ampacity of a 14 AWG conductor would be 20 amps at 30°C. If the PV combiner were operating at 63°C, the fuse would have to be temperature corrected according to the manufacturer's instruction and the use of 14 AWG conductors would still be acceptable when evaluated at 7 amps.

This cable is protected with a 9-amp fuse.

The cable from the PV combiner to the main PV disconnect operates at 40°C. The temperature derating factor for RHW-2 with 90°C insulation is 0.91. This yields a 30°C ampacity requirement of 58 amps ($52.5 / 0.91$). RHW-2 6 AWG meets this requirement with an ampacity of 75 amps (90°C insulation), and a number 6 AWG cable with 75°C insulation has an ampacity of 65 amps, which also exceeds the 42 amp requirement for overcurrent devices with 75°C terminals.

Overcurrent protection is provided with a 60-amp fused disconnect. Since the negative dc conductor of the array is grounded, only a single-pole disconnect is needed.

The inverter output current is 21 amps ($5000 / 240$).

80% OPERATION: $1.25 \times 21 = 26$ amps.

The cable from the inverter to the load center operates at 30°C. Cable size 8 AWG RHW-2 (evaluated with 75°C insulation) has an ampacity of 50 amps.

A back-fed 30-amp, two-pole circuit breaker provides an ac disconnect and overcurrent protection in the load center.

The equipment-grounding conductors for this system should be at least 10 AWG conductors. The ac and dc grounding electrode conductors should be a 6 AWG

conductor. An 8 AWG grounding electrode conductor might be allowed if provided with physical protection by installing in conduit.

Although not shown on the diagram, there will be a dc grounding electrode conductor from the inverter to a separate dc grounding electrode (or system). The dc grounding electrode must be bonded to the ac grounding electrode. Alternatively, the dc grounding electrode conductor may be connected directly to the ac grounding electrode.

All dc circuits should have a voltage rating of at least 310 volts ($1.25 \times 4 \times 62$). Typically, 600-volt rated conductors, fuses, and related dc equipment would be used.

EXAMPLE 8 Integrated Roof Module System, Utility-Interactive

Array Size: 192, 12-volt, 22-watt thin-film modules
 $I_{sc} = 1.8$ amps
 $V_{mp} = 15.6$ volts
 $V_{oc} = 22$ volts

Inverter: ± 180 -volt dc input
120-volt ac output
4000 watts
95% efficiency

Description

The array is integrated into the roof as the roofing membrane. The modules are connected in center-tapped strings of 24 modules each. Eight strings are connected in parallel to form the array. Strings are grouped in two sets of four and a series fuse protects the module and string wiring as shown in Figure E-8. The bipolar inverter (not currently in production) has the center tap dc input and the ac neutral output grounded. The 120-volt ac output is fed to the service entrance load center (fifty feet away) through a back-fed circuit breaker.

The manufacturer of these thin-film modules has furnished data that show that the maximum V_{oc} under worst-case low temperatures is 24 volts. The multiplication factor of 1.25 on V_{oc} does not apply [690.7(A)]. The design voltage will be $24 \times 24 = 576$ volts. The module manufacturer has specified (label on module) 5-amp module protective fuses that **must** be installed in each (+ and -) series string of modules.

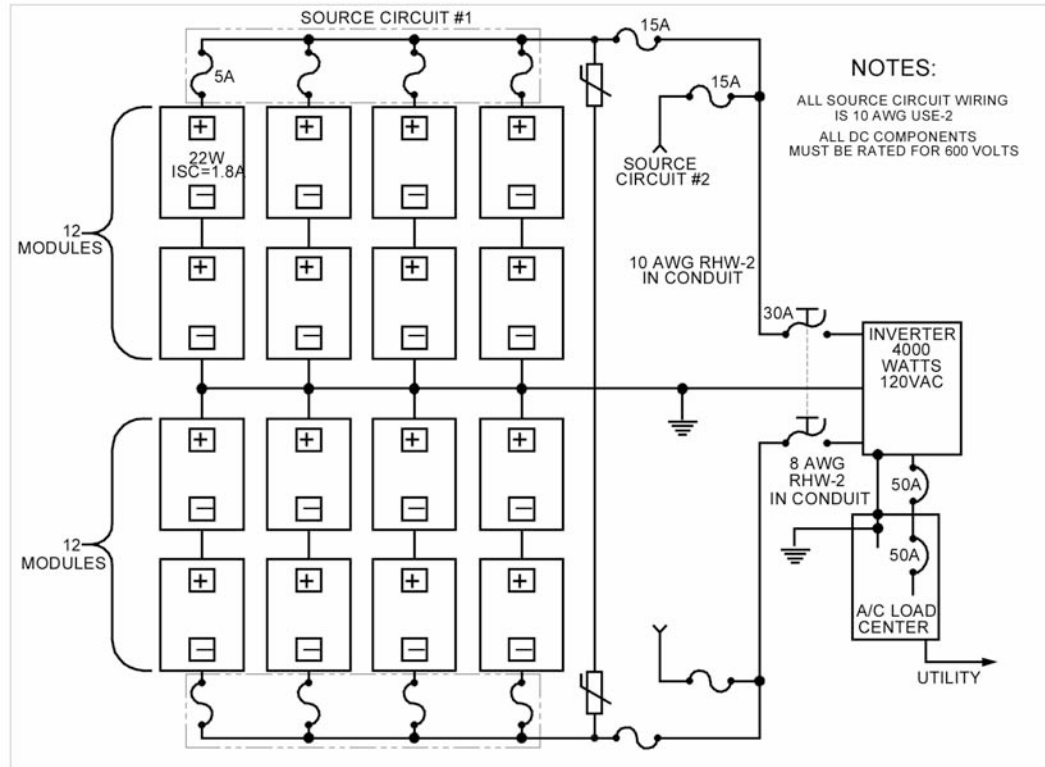

Figure E-8. Center-Tapped PV System

Calculations

Each string short-circuit current is 1.8 amps.

CONTINUOUS CURRENT (estimated for thin-film modules): $1.25 \times 1.8 = 2.25$ amps

80% OPERATION: $1.25 \times 2.25 = 2.8$ amps

Each source circuit (4 strings) short-circuit current is 7.2 amps (4×1.8).

CONTINUOUS CURRENT: $1.25 \times 7.2 = 9$ amps

80% OPERATION: $1.25 \times 9 = 11.25$ amps

The array (two source circuits) short-circuit current is 14.4 amps (2×7.2).

CONTINUOUS CURRENT: $1.25 \times 14.4 = 18$ amps

80% OPERATION: $1.25 \times 18 = 22.5$ amps

USE-2 cable is used for the module connections and operates at 75°C when connected to the roof-integrated modules. The temperature-derating factor in the wiring raceway is 0.41. For the strings, the 30°C ampacity requirement is 5.5 amps ($2.25 / 0.41$)[310.16].

Each source circuit conductor is also exposed to temperatures of 75°C. The required ampacity for this cable (at 30°C) is 22.0 amps ($9 / 0.41$).

Wire size 10 AWG USE-2 is selected for moisture and heat resistance. It has an ampacity of 40 amps at 30°C (90°C insulation) and can carry 35 amps when limited to a 75°C insulation rating (used for evaluating terminal temperature limitations on the fuses). This cable is used for both string and source-circuit wiring. Fifteen-amp fuses are used to protect the string and source-circuit conductors.

The array wiring is inside the building and RHW-2 is used in metal conduit (2005 *NEC* 690.31(E)). It is operated at 50°C when passing through the attic. The temperature derating factor is 0.82, which yields a 30°C ampacity requirement of 22 amps (18 / 0.82). Cable size 10 AWG has an ampacity of 40 amps (90°C insulation) or 35 amps (evaluated with 75°C insulation). Both of these ampacities exceed the 22-amp requirement. Twenty-five amp fuses are required to protect these cables, but 30-amp fuses are selected for better resistance to surges. Since the inverter has high voltages on the dc-input terminals (charged from the ac utility connection), a load-break rated, pullout fuse holder is used.

The inverter is rated at 4000 watts at 120 volts and has a 33-amp output current. The ampacity requirement for the cable between the inverter and the load center is 42 amps ((4000 / 120) x 1.25) at 30°C. Wire size 8 AWG RHW-2 in conduit connects the inverter to the ac-load center, which is fifty feet away and, when evaluated at with 75°C insulation, has an ampacity of 50 amps at 30°C. A 50-amp circuit breaker in a small circuit-breaker enclosure is mounted next to the inverter to provide an ac disconnect for the inverter that can be grouped with the dc disconnect. Another 50-amp circuit breaker is back-fed in the service entrance load center to provide the connection to the utility.

The modules have no frames and, therefore, no equipment grounding requirements. The inverter and switchgear should have 10 AWG equipment grounding conductors. The dc system grounding electrode conductor (GEC) should be an 8 AWG conductor installed in conduit for mechanical protection. This dc GEC is connected to the existing ac GEC.

All dc components in the system should have a minimum voltage rating of 600 volts (24 x 24 = 576).

Example 9 Residential Utility-Interactive, Multiple-Inverter System

PV array: 3, 12-module strings of 185 watt, 24V modules
 $V_{oc} = 42V$
 $I_{sc} = 6.2A$

Inverters: 3, 2500-watt, 240Vac output

Residential Service Entrance/Load Center: 200A with 200A main circuit breaker

The PV modules are connected in three series strings of 12 modules each. The coldest ambient temperature is 15°F. Maximum system voltage is 570V (12 x 42 x 1.13) [690.7]. Each series string is connected to one pole of a Square D HU361RB heavy-duty safety switch with a special listing suitable for this application (each pole rated at 600 volts dc). The three outputs of the disconnect are connected to three 2500-watt inverters.

The modules are connected in series with the attached 14 AWG USE-2 conductors and attached connectors.

At a 75°C operating temperature, the 14 AWG USE-2 conductors in free air have an ampacity of 14 amps (35 x 0.41) which is higher than the 10 amps needed (6.2 x 1.56). At the ends of each string of 12 modules, the 14 AWG conductors are spliced (soldered and covered with listed, outdoor-rated heat-shrink tubing [110.14(B)]) to 10 AWG USE-2/RHW-2 conductors which are run in conduit to the readily accessible Square D disconnect located on the outside of the residence near the utility meter [690.14(C)].

The inverter has been certified by the manufacturer as having no capability to backfeed ac current from the utility grid into faults in the dc PV wiring and therefore no overcurrent devices are required in the dc PV disconnect [690.9(A)EX]. The local inspector must accept or reject this certification until the UL Standard 1741 for inverters includes a test for back feeding from the utility.

Inverter output current is 10.4 amps (2500/240)
Ampacity requirements: 13 amps (10.4 x 1.25)
Circuit breaker for each inverter: 15 amps

The ac output conductors of the inverter could be 14 AWG THWN-2 that meets ampacity requirements at 45°C and with 75°C insulation (circuit breaker terminal temperature limitations). However, 10 AWG THWN-2 conductors were used to minimize voltage rise between the inverter outputs and the utility point of connection.

NEC section 690.64(B)(2) imposes a 40-amp maximum PV backfed circuit breaker rating limitation on the main panel (1.2 x 200 – 200). Connecting three double-pole 15-amp circuit breakers from the inverters would total 45 amps exceeding the limitation of 40 amps. Each bus of the 120/240 load center should be analyzed separately, but they are identical in this example. Therefore, a subpanel is used to combine the output of the three inverters before sending the combined output to the main panel.

Subpanel Main Breaker: $3 \times 10.4 \times 1.25 = 39$ amps, round to 40 amps

Subpanel rating from 690.64(B)(2) where X is minimum subpanel rating:

$1.20 X = 3 \times 15 + 40 = 85$, $X = 70.8$, round up to 100 amp panel size.

Conductors between subpanel and main panel must be rated for 39 amps.

8 AWG THHN in conduit is rated at 46.2 amps (55 x 0.91) at 45°C. With 75°C insulation, the ampacity is 50 amps at 30°C and 41 amps at 45°C. Both are adequate for the required 40 amps.

A 40-amp backfed breaker is installed in the main panel for the residence and meets NEC 690.64(B)(2) at this location.

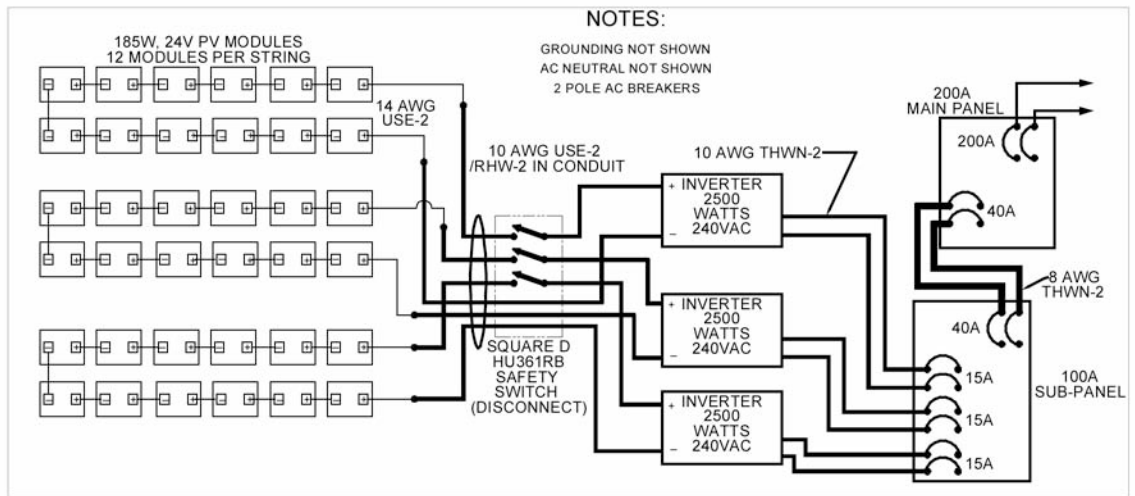

Figure E-9. Utility-Interactive Three-Inverter System

APPENDIX F: DC Currents on Single-Phase Stand-alone Inverters

When the sinusoidal ac output current of a stand-alone inverter goes to zero 120 times per second, the input dc current also goes nearly to zero. With a resistive ac load connected to the inverter, the dc current waveform resembles a sinusoidal wave with a frequency of 120 Hz. The peak of the dc current is significantly above the average value of the current, and the lowest value of dc current is near zero.

An example of this is shown in the Figure F1. This is an example of a single-phase stand-alone inverter operating with a 4000-watt resistive load. The input battery voltage is 22 volts. The figure shows the dc current waveform. The measured average dc current is 254 amps. The RMS value of this current is 311 amps.

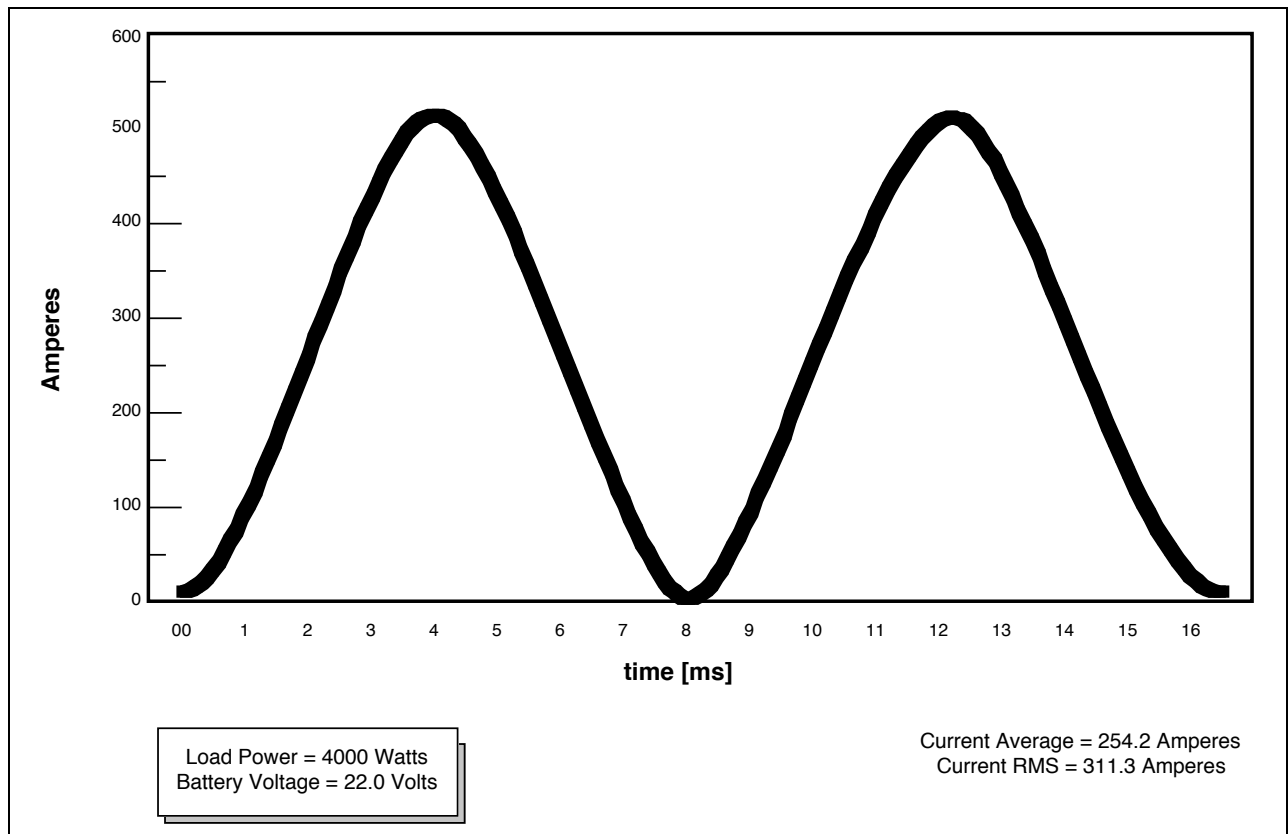

Figure F-1. Inverter Current Waveform (dc side)

The calculated dc current for this inverter (as was done in Example 6 in Appendix E) is 214 amps ($4000/22/0.85$) when using the manufacturer's specified efficiency of 85%.

The RMS value of current is the value that causes heating in conductors and is the value of current that causes overcurrent devices to trip. In this case, if the inverter were operated at 100%

of rated power and at a low battery voltage, the conductors and overcurrent devices would have to be rated to carry 311 amps, not the calculated 214 amps. Code requirements would increase the cable ampacity requirements and overcurrent device ratings to 388 amps (1.25 x 311).

Loads that have inductive components may result in even higher RMS values of dc currents.

The systems designer should contact the inverter manufacturer in cases where it is expected that the inverter may operate at loads approaching the full power rating of the inverter. The inverter manufacturer should provide an appropriate value for the dc input current under the expected load conditions.

Some inverters may employ topologies that filter the dc input current resulting in less ripple

APPENDIX G: Grounding PV Modules

Grounding PV modules to reduce or eliminate shock and fire hazards is necessary but difficult. Copper conductors are typically used for electrical connections, and the module frames are generally aluminum. It is well known that copper and aluminum do not mix as was discovered from numerous fires in houses wired with aluminum wiring in the 1970's. PV modules generally have aluminum frames. Many have mill finish, some are clear coated, and some are anodized for color. The mill finish aluminum and any aluminum surface that is scratched quickly oxidizes. This oxidation and any clear coat or anodizing form an insulating surface that makes for difficult long-lasting, low resistance electrical connections (e.g. frame grounding). The oxidation/anodizing is not a good enough insulator to prevent electrical shocks, but it is good enough to make good electrical connections difficult.

Underwriters Laboratories (UL) which tests and lists all PV modules sold in the US requires very stringent mechanical connections between the various pieces of the module frame to ensure that these frame pieces remain mechanically and electrically connected over the life of the module. These low-resistance connections are required because a failure of the insulating materials in the module could allow the frame to become energized at up to 600 volts (depending on the system design). The *National Electrical Code (NEC)* requires that any exposed metal surface be grounded if it could be energized. The installer of a PV system is required to ground each module frame. The Code (110.3(B)) and UL Standard 1703 require that the module frame be grounded at the point where a designated grounding provision has been made. The connection must be made with the hardware provided using the instructions supplied by the module manufacturer.

The designated point marked on the module must be used since this is the only point tested and evaluated by UL for use as a long-term grounding point. UL has established that using other points such as the module structural mounting holes coupled with typical field installation "techniques" do not result in low-resistance, durable connections to aluminum module frames. If each and every possible combination of nut, bolt, lock washer and star washer could be evaluated for electrical properties and installation torque requirements AND the installers would all use these components and install them according to the torque requirements, it might be possible to use the structural mounting holes for grounding.

New grounding devices are coming to market that will eventually ease the problems of module grounding, but until the module instructions address these devices, they do not meet the requirements of *NEC* Section 110.3(B).

Most US PV module manufacturers are providing acceptable grounding hardware and instructions. Japanese module manufactures are frequently providing less-than-adequate hardware and unclear instructions. Future revisions of UL 1703 should address these issues. In every case, the module manufacturer's hardware and instructions should be used (where possible) to ground the module at the points marked on the frame.

In the meantime, installers have to struggle with the existing hardware and instructions, even

when they are poor. SWTDI has identified suitable grounding hardware and provides that information when installers ask about grounding—a frequent topic.

For those modules that have been supplied with inadequate or unusable hardware or no hardware at all, here is a way to meet the intent of the code and UL Standard 1703.

For those situations requiring an equipment-grounding conductor larger than 10 AWG, a stainless steel 10 screw, nut and lock washer can be used to attach an ILSCO GBL4 DBT , Burndy CL50-DB-T, or equivalent lug to the module frame at the point marked for grounding.. Before attaching the lug to the module, a stainless steel brush should be used to remove any anodization or oxidation from the aluminum module frame and a thin coat of anti-oxidant film is placed on the clean aluminum surface. Burndy Penetrox A-13 or equivalent should be used. Some new grounding lugs have been listed for use without the anti-oxidant compound since the design of the lug penetrates the oxidation. It is not acceptable to use the hex-head, green grounding screws (even when they have 10-32 threads) because they are not suitable for outdoor exposure and will eventually corrode. The same can be said for other screws, lugs, and terminals that are not suitable outdoor applications. (See Figure G-1.)

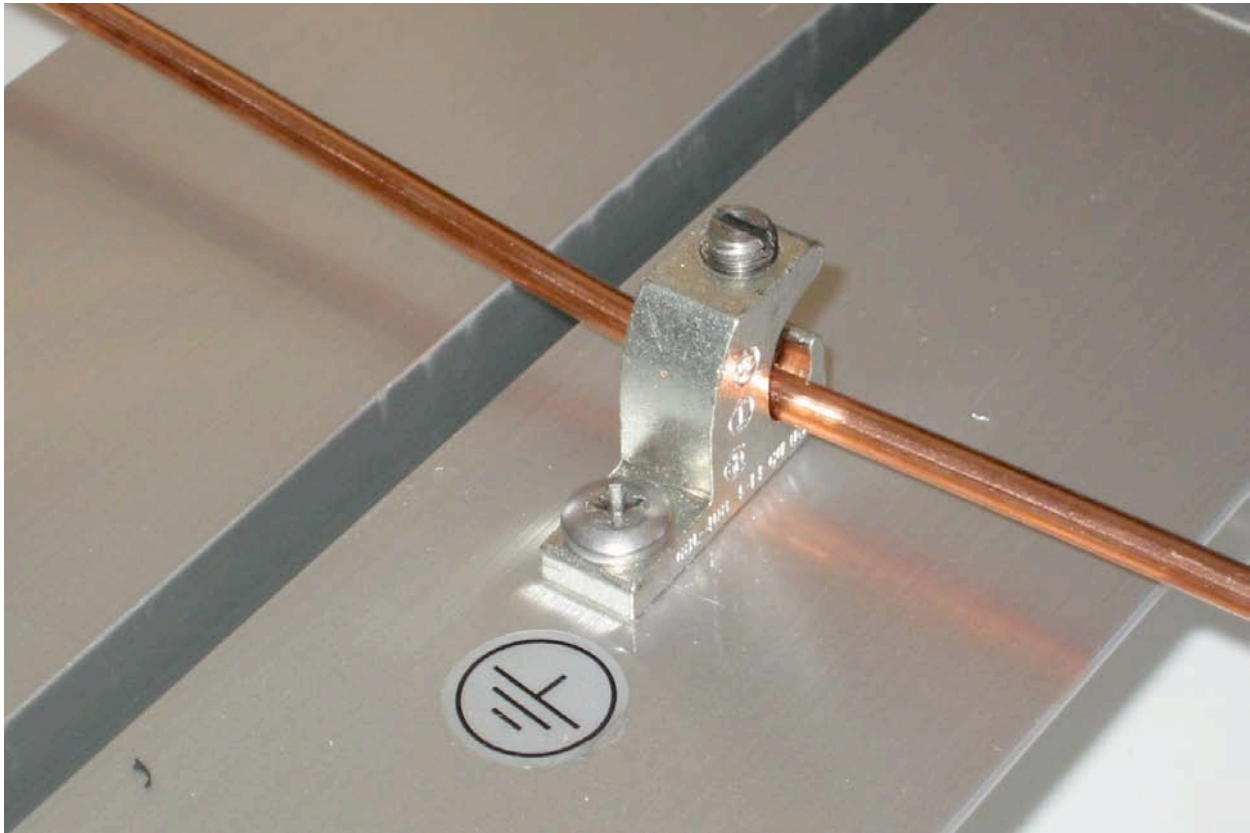

Figure G-1. ILSCO GBL4-DBT Lug

The ILSCO GBL4 DBT and the Burndy CL50-DB-T lug are tin plated lay-in lugs made of solid copper with a stainless steel screw. They accept a 4 AWG to 14 AWG copper conductor. They are listed for direct burial use (DB) and outdoor use and can be attached to aluminum structures

(the tin plate allows this). The much cheaper ILSCO GBL4 lug and the Burndy equivalent look identical but are tin plated aluminum, have a plated screw, and are not listed for outdoor use. If the module grounding is to be done with a 14 AWG to 10 AWG conductor, then the ILSCO lug is not needed.

What size conductor should be used? The minimum code requirement is for the equipment grounding conductor for PV source and output circuits to be sized to carry 1.25 times the short-circuit currents at that point. While this may allow a 14 AWG conductor between modules, a conductor this small would require physical protection between the grounding points. Some inspectors will allow a 10 AWG bare conductor to be routed behind the modules from grounding point to grounding point if the conductors are well protected from damage, as they would be in a roof-mounted array. If needed, an 8 AWG or 6 AWG sized conductor may be required (to meet the code or to satisfy the inspector) and then the ILSCO lugs should be used.

It is desirable to use the module mounting structure for grounding. Rack manufacturers have been urged to get their products listed as field-installable grounding devices, and some progress is being made in this area. However, the module manufacturers will have to modify the instruction manuals to allow alternate grounding methods.

The code allows metal structures to be used for grounding and even allows the paint or other covering to be scraped away to ensure a good electrical contact. Numerous types of electrical equipment are grounded with sheet metal screws and star washers. This works on common metals like steel, but not on aluminum due to the oxidation.

Module manufacturers are being encouraged to make that aluminum connection in the factory and to provide a copper-compatible terminal in the j-box or on the frame as is done with the 300-watt RWE-Schott modules.

Unfortunately many PV systems are being grounded improperly even when the proper hardware has been supplied. Figure G-2, a photo taken in March 2004, illustrates that even the proper hardware can be misused. Here, the stainless-steel isolation washer has been installed in the wrong sequence and the copper grounding wire is being pushed against the aluminum frame; a condition sure to cause corrosion and loss of electrical contact in the future.



Figure G-2. Improper Module Grounding

APPENDIX H: PV Ground Fault Protection Devices and The *National Electrical Code*, Section 690.5

Section 690.5, Ground Fault Protection, of the 1987 *National Electrical Code (NEC)* added new requirements for photovoltaic (PV) systems mounted on the roofs of dwellings. The requirements are intended to reduce fire hazards resulting from ground faults in PV systems mounted on the roofs of dwellings. There is no intent to provide any shock protection since the 5ma level of protection would not be possible on a PV array with distributed leakage currents, and the requirement is not to be associated with a direct current (dc) GFCI. The ground fault protection device (GFPD) is intended to deal only with ground faults and not line-to-line faults.

The requirements for the ground-fault protection device have been modified in subsequent revisions of the Code. The requirements for the device in the current code are as follows.

1. Detect a ground fault
2. Interrupt the fault current
3. Indicate that there was a ground fault
4. Open the ungrounded PV conductors

As the 1990 *NEC* was published, no hardware had been developed to meet these requirements. Under a two-year contract (1990-1991) from the Salt River Project, a Phoenix, Arizona utility, John Wiles at the Southwest Technology Development Institute at New Mexico State University developed prototype designs and hardware to meet the requirements. The designs were released to the PV industry and GFPDs based on these designs and other concepts began appearing in PV equipment and subsystems in the late 1990's. Listed equipment is now available for both stand-alone and utility-interactive systems.

To understand how these GFPDs work, it must be understood that nearly all currently available inverters, both stand-alone and utility-interactive, employ a transformer that isolates the dc grounded circuit conductor (usually the negative) from the ac grounded circuit conductor (usually the neutral). With this transformer isolation, the dc side of a PV system may be considered similar to a separately derived system and, as such, must have a single dc bonding connection that connects the dc grounded circuit conductor to a common grounding point where the dc equipment-grounding conductors and the dc grounding electrode are connected. Like grounded ac systems, only a single dc bonding connection is allowed. If more than one bonding connection (a.k.a. bonding jumper) were allowed on either the ac side of the system or on the dc side of the system, unwanted currents would circulate in the equipment-grounding conductors and would violate *NEC* Section 250.6.

Currently available GFPDs as both separate devices for adding to stand-alone PV systems and as internal circuits in most utility-interactive inverters serve as the dc bonding connection.

In any ground-fault scenario on the dc side of the PV system, ground-fault currents from *any* source (PV modules or batteries in stand-alone systems) must eventually flow through the dc

bonding connection on their way from the energy source through the fault and back to the energy source. This includes single ground faults involving the positive conductor faulting to ground or in the negative conductor faulting to ground. In negative-conductor (a grounded conductor) ground faults, parallel paths for the negative currents are created by the fault path and they will flow through the dc bonding connection. Double ground faults are beyond the ability of any equipment to deal with and are not required to be addressed by the *NEC* or standards established by Underwriters Laboratories (UL).

To meet the *NEC* Section 690.5 requirements, a typical GFPD has a 1/2 amp to 1 amp and sometimes 5 amp overcurrent device installed in the dc bonding connection. When the dc ground-fault currents exceed the current rating of the device, it opens. By opening, the overcurrent device interrupts the ground-fault current as required in *NEC* Section 690.5. If a circuit breaker is employed as the overcurrent device, the tripped position of the breaker handle provides the indicating function. When a fuse is used, an additional electronic monitoring circuit in the inverter provides an indication that there has been a ground-fault. The indication function is also an *NEC* 690.5 requirement. There is no automatic resetting of these devices.

In the GFPD using a circuit breaker as the sensing device, an additional circuit breaker is mechanically connected (common handle/common trip) to the sensing circuit breaker. These types of GFPDs may be found in both stand-alone and utility-interactive systems. This additional circuit breaker (usually rated at 100 amps and used as a switch rather than an overcurrent device) is connected in series with the ungrounded circuit conductor from the PV array. In this manner, when a ground-fault is sensed and interrupted, the added circuit breaker disconnects the PV array from the rest of the circuit providing an additional indication that something has happened that needs attention.

Even though the GFPD uses a 100-amp circuit breaker in the ungrounded PV conductor, the 100-amp circuit breaker *may not* be used as the PV disconnect because in normal use of the system, turning off this breaker would unground the system and this is undesirable in non-fault situations.

In the GFPD installed in utility-interactive inverters using a fuse as the sensing element, the electronic controls in the inverter that indicate that there has been a fault, also turn the inverter off and open the internal connections to the ac line. In listing these inverters, UL had indicated that this method of turning off the inverter to provide an additional indication of trouble meets the requirements of 690.5(B) for disconnecting the ungrounded PV conductor.

It should be noted that the dc GFPD detects and interrupts ground faults **anywhere** in the dc wiring and the GFPD may be **located anywhere** in the dc system. Because the normal location for the dc bonding connection is at or near the dc disconnect, this bonding connection is usually made at the dc power center where there is ready access to the dc grounding electrode. GFPDs installed in the utility-interactive inverters or installed in dc power centers on stand-alone systems are the most logical places for these devices. There is no significant reason to install them at the PV module location. This configuration would significantly increase the length of the dc grounding electrode conductor and complicate its routing. To achieve significant additional safety enhancements would require a GFPD at every module. Equipment to do this does not exist and there are no requirements for such equipment.

The diagram (Figure H-1) shows both positive (red) and negative (blue) ground faults and the paths that the fault currents take. As noted above, all ground fault currents must pass through the dc bonding connection where the GFPD sensing device is located.

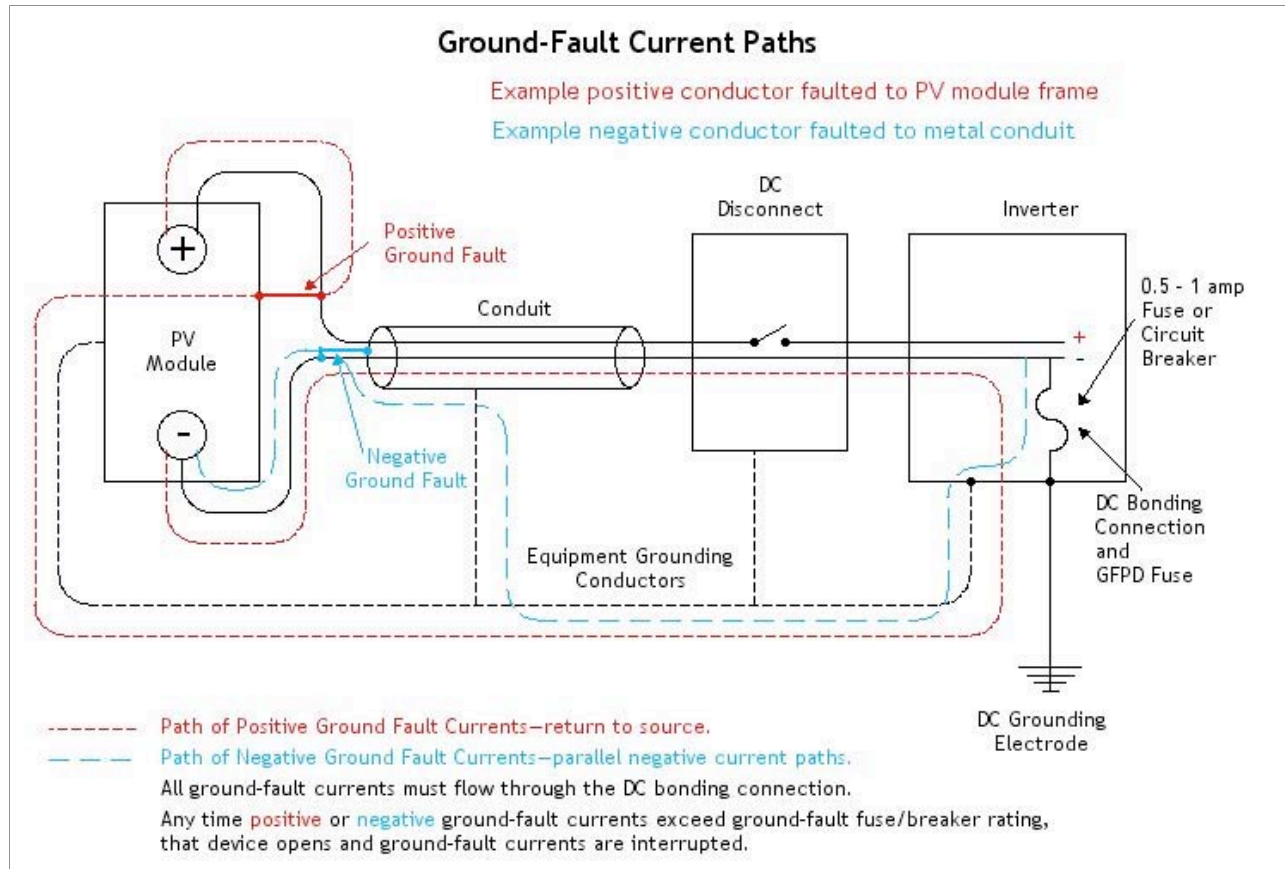

Figure H-1. Ground-Fault Current Paths

These devices are fully capable of interrupting ground faults occurring anywhere in the dc system including faults at the PV array or anywhere in the dc wiring from the PV module to the inverter and even to the battery in stand-alone systems. All of this can be done from any location on the dc circuit. Fire reduction and increased safety are achieved by having these GFPD on residential PV systems. Keeping the PV source and output conductors outside the dwelling until the point of first penetration and requiring the readily accessible dc disconnect also enhance the safety of the system. See Section 690.14 of the Code for details. The 2005 NEC allows conductors in metallic raceways to be routed inside the structure. [690.31(E)]

During a ground-fault, the dc system bonding connection is opened, and if the ground fault cures itself for some reason (e.g., an arc extinguishes), the dc system remains ungrounded until the system is reset. A positive-to-ground fault may allow the negative conductor (now ungrounded) to go to the open-circuit voltage with respect to ground. This is addressed by the marking requirements of Section 690.5(C). A very high value resistance is usually built into the GFPD and this resistance bleeds off static electric charges and keeps the PV system loosely referenced to ground (but not solidly grounded) during ground-fault actions. The resistance is selected so that any fault currents still flowing are only a few milliamps—far too low to be a fire hazard.

APPENDIX I: Selecting Overcurrent Devices and Conductors in PV Systems

1. Define Continuous Currents

The unique nature of PV power generators dictate that all ac and dc calculated currents are continuous and are based on the worst-case conditions. There are no non-continuous currents and all currents are treated as continuous.

- A. DC currents in PV source and PV output circuits are calculated as 125% of the short-circuit current (I_{sc}) (690.8(A)(1)).
- B. AC inverter (stand-alone or utility-interactive) output currents are calculated at the rated output of the inverter (690.8(A)(3)).
- C. DC inverter input currents from batteries are calculated based on the rated output power of the inverter at the lowest battery voltage that can maintain that output (690.8(A)(4)). Inverter dc to ac efficiency must also be factored into the calculation.

2. Select Overcurrent Device

- A. The overcurrent device will be rated at 125% of continuous current (690.8(B)(1)).
 - 1.) If the overcurrent device is in a listed assembly and the combined assembly is listed for 100% duty, then use 100% continuous current to size the overcurrent device (690.8(B)(1) EX)).
 - 2.) The calculated value of the overcurrent device may be rounded up to next standard rating (where the rating is less than or equal to 800A (240.4(B)). Standard values of overcurrent devices in PV source and output circuits are 1-15 amps in 1-amp increments (690.9(C)).

In PV source circuits, the value should be less than or equal to the value of the maximum series protective fuse marked on the back of the module. If desired (for unforeseeable reasons), this selected value could be increased to the size of the maximum protective fuse found on the back of the module. However, this will impact conductor sizing and other overcurrent device requirements.

- B. If the overcurrent device is exposed to temperatures (operating conditions) greater than 40°C, temperature correction factors must be applied to the device rating (110.3(B)).

3. Select Conductor

- A. A conductor should be selected with a 30°C ampacity *not less than* 125% of continuous current (215.2(A)(1)).
- B. The conductor selected must have 30°C ampacity after corrections for conditions of use (ambient temperature and conduit fill) *not less than* the continuous currents (no 125% used at this time).
 - 1.) Apply the conductor selection requirements at all points of different temperatures and or conduit fill.
 - 2.) Use the 10%/10-foot rule where appropriate (310.15(A)(2) EX).
- C. Select the larger conductor from 3.A. or 3.B (310.15(A)(2)).

4. Evaluate conductor temperature at each termination

- A. A current for conductor size selected in 3.C should be selected from Table 310.16 using 60°C or 75°C ampacity columns depending on conductor temperature rating of the device terminals (110.14(C)).
- B. If the terminals are in an ambient temperature greater than 30°C, the current found in 4.A. should be derated for the higher temperature using the correction factors at the bottom of the 60°C or 75°C columns as appropriate.
- C. The current in 4.B. must *not be less than* 125% of continuous current.
- D. Increase the conductor size, if necessary, to meet 4.C at all terminations.

5. Verify that the Overcurrent Device Protects Conductors

- A. The rating of the overcurrent device (after any corrections for conditions of use— 2.B.) selected in 2 must *not be more than* the ampacity of the conductor selected in 4.C. The ampacity used for the conductor is that found under the conditions of use (3). Rating round up is allowed (240.4(B)).
- B. A larger conductor size should be selected if the conductor selected in 4.C is not protected by the overcurrent device.

APPENDIX J: FUSING OF DC PV MODULE CIRCUITS IN UTILITY-INTERACTIVE PV SYSTEMS

In most electrical systems, the *National Electrical Code (NEC)* requires every ungrounded circuit conductor be protected from overcurrents that might damage that conductor. Overcurrent protective devices (OCPD), either fuses or circuit breakers, provide that function. However, some of the smaller utility-interactive PV systems may not need OCPD in the dc circuits that are connected to the PV modules.

The *NEC* assumes that each ungrounded conductor is connected to some source of overcurrents that might potentially damage that conductor under fault conditions. This source could be a power supply, a utility service, or a battery that supplies currents in excess of the ampacity rating of the conductor. PV modules are current limited devices, and their worst-case, continuous outputs for Code calculations are 1.25 times the rated short-circuit current. An exception to Section 690.9(A) allows conductors to be used with no OCPD where there are no sources of external currents that might damage that conductor.

Additionally, Underwriters Laboratories (in UL Standard 1703) has established that modules must have an *external* series OCPD if *external* sources of current can damage the *internal* module conductors. The module can be damaged if reverse currents are forced through the module (due to an external or internal fault) that are in excess of the values of the maximum series fuse marked on the label on the back of the module. Again, if there are no sources of external currents that exceed this marked value, then no OCPD is needed to protect the internal module wiring.

External sources of current (apart from the module or series-connected strings of modules) vary from system to system. These currents can originate from modules or series-connected strings of modules that are connected in parallel to the module of interest, from batteries in the system, or from utility currents backfeeding through utility-interactive inverters.

In systems with batteries and charge controllers, the batteries are a very predominate source of currents and, generally, OCPD will be required on each module or series-connected string of modules. Generally, only one OCPD will be required to protect all modules connected in a single series string. A properly sized and located OCPD will protect not only the conductors, but also the modules from external overcurrents.

In utility-interactive systems, some inverter designs are capable of allowing current from the utility to flow backwards through the inverter into faults in the PV array. Systems using these types of inverters would typically require OCPD at the inverter dc inputs or OCPD on each string of modules or OCPD in both locations. Many of the smaller utility-interactive inverters (below about 6 kW) are designed so that they cannot backfeed currents from the utility into array faults. However, there are currently (1/7/07) no tests in the UL 1741 to validate the lack of backfeeding from the utility, so a manufacturer's certification should be obtained that the inverter cannot backfeed from the utility into an array fault.

The general case—most larger PV systems

The most common situation occurs in systems where there are multiple strings of modules connected in parallel. The non-faulted strings may be able to supply sufficient overcurrents (through the parallel connection) to damage either the conductors or the modules in the faulted strings. A basic question is: How many PV modules or strings of modules can be connected in parallel and still meet the *National Electrical Code (NEC)* and Underwriters Laboratories (UL) requirements (marked on the back of each module) before a OCPD is needed on each module/string of modules? UL marks the modules based on reverse-current tests. The *NEC* requires that the manufacturer's instructions and labels be followed. The intent of the module marking is to protect the conductors internal to the module at the marked level from reverse currents. This is a maximum value for the OCPD. Lesser values can be used as long as they meet the *NEC* requirement of $1.56 \cdot I_{sc}$ to protect the conductor associated with the module or string of modules. In some cases, the value of the module protective overcurrent device is less than $1.56 \cdot I_{sc}$. This poses a Code conflict (110.3(B) vs. 690.8/9) and is an issue for UL to rectify.

Many installers of 12-, 24-, and 48-volt PV systems ignore the module OCPD requirement and connect modules/strings in parallel. Can it be done and how? Dave King at Sandia National Laboratories and I have smoked a few modules and determined that the module OCPD requirement is valid.

It is easy to see that in a one-string system, an OCPD is needed only when the inverter or battery is a source of overcurrents. No fusing would be required in a one-string system if there were no battery or inverter that could source overcurrents.

Consider n modules or strings of modules connected in parallel. The *NEC* requires that an OCPD be installed in the combined paralleled output of all strings (modules) to protect the cable from reverse currents from batteries and back feed of ac currents through an inverter. In this case, we are assuming that the inverter or the batteries are a potential source of overcurrents. The OCPD will have a minimum rating of $1.56 \cdot n \cdot I_{sc}$ amps. It is sized at this value to allow maximum forward currents from the array to pass through without interruption and to keep the overcurrent device from operating at more than 80% of rating.

Examine a circuit where there are n modules/strings connected in parallel. Place a ground-fault in one module/string. Examine the sources of fault current that would affect that module string. Let us ignore current from the faulted module/string itself since the wiring in that string is already sized to carry all currents generated in the string.

First, there is the back feed current from the battery or the inverter in those systems with these components. It is limited to the *NEC* required OCPD of $1.56 \cdot n \cdot I_{sc}$. This current is added to the current from the remaining modules connected in parallel. In this case, the current is $(n-1) \cdot 1.25 \cdot I_{sc}$. The 1.25 is required because of daily-expected irradiance values that are greater than the STC-rated I_{sc} .

$$I\text{-fault} = 1.56 \cdot n \cdot I_{sc} + (n-1) \cdot 1.25 \cdot I_{sc}$$

With a little algebra, the resulting fault current is:

$I\text{-fault} = (2.81 * n - 1.25) * I_{sc}$ amps. (Fault Current Equation)

Note that this equation does not account for rating roundup of the OCPD, so each system must be checked with the actual OCPD values.

If the module can pass the UL reverse current test at this I-fault value or greater and be so marked (the maximum protective series fuse on the label), then it is possible to parallel n modules/strings (pick your n) without a series OCPD for each module/string.

For example, a PV module is rated at 60 watts and has a maximum series OCPD requirement of 20-amps, which is marked on the back of the module. The I_{sc} for this module is 3.8 amps. Here are the required calculations and checks for two strings in parallel.

The paralleled circuit OCPD installed at the output of the two paralleled strings will be $2 * 1.56 * 3.8 = 11.8$ amps. Assume a 12 amp OCPD is used since the *NEC* now requires module/string OCPDs in one-amp increments up to 15 amps; fuses are available in these values except there is a jump from 10 to 12 and then to 15. This OCPD will allow 12 amps of fault current to reach the faulted module/string from backfeed from a charge controller/battery or from the utility grid through a utility-interactive inverter. Another $1.25 * 3.8 = 4.75$ amps will come from the parallel-connected module/string for a total of 16.75 amps. This is acceptable since this module is marked for 20 amps.

However, if we try to parallel three of these modules/strings, the fault current equation yields a fault current of 29+ amps that exceeds the 20-amp limit on the module. The single OCPD is $3 * 1.56 * 3.8 = 17.8$ amps (since OCPDs at this rating are not common, a 20-amp OCPD must be used). The two parallel-connected modules contribute $2 * 1.25 * 3.8 = 9.5$ amps for a total potential fault current of 29.5 amps. This is significantly above the maximum series protective fuse of 20 amps.

In most cases, it is not possible to parallel many more than 2 modules/strings with a single OCPD unless the marked maximum series OCPD is very large in relation to I_{sc} for the module. Some of the thin-film technologies may be able to do this and that will be an installation benefit for them.

Questions about driving voltages to produce these currents? The faults can occur anywhere in the module/string so a fault involving a single cell could be the trouble spot, and driving voltages over 1 volt could produce the reverse currents.

What about currents generated within the faulted module string? In the portion of the module/string below the fault (toward the grounded end of the module/string), the currents flow in the forward direction toward the fault and may or may not cause problems. As far as the contribution to the fault current is concerned, the contribution only appears in the fault path/arc and does not affect the ampacity of the cable. Above the fault (toward the ungrounded end), the currents in that portion of the module/string appear to oppose the external fault currents that are trying to reverse the flow of current, but the string is reversed biased, and the external driving currents are flowing. Since the location of the fault cannot be controlled ahead of time, worst-case currents must be assumed.

The increased marking value of 20 amps on the example module allows for two modules/strings to be connected in parallel and it does make it easier for the installer to use a single OCPD with larger cable to meet both the *NEC*-required cable protection and the UL-required module protection with one large OCPD instead of a two smaller OCPDs plus a larger OCPD.

Conductor ampacity must also be addressed if modules are going to be paralleled on a single OCPD. The conductors for each string must be able, under fault conditions, to carry the current from the other parallel strings (modules) plus the current that may be backfed from the inverter or battery. In the case with n strings in parallel and a single OCPD in the combined output, the conductor ampacities would be as follows:

Each of the string conductors would have to have an ampacity of $1.25 (n-1)I_{sc} + 1.56 n I_{sc}$. If the equation is factored, the required ampacity becomes $A=(2.81*n-1.25)*I_{sc}$. As before, OCPD roundup is not considered and the values should be recalculated with actual OCPD values. The combined output-circuit conductors would require an ampacity of $1.56*n*I_{sc}$.

Modern, small utility-interactive inverters

Many utility-interactive inverters on the market have redundant internal circuitry that prevents currents from being backfed through the inverter from the utility to faults in the PV array. This removes one source of currents in the above equation. With these products, it is possible to have two and sometimes more strings of modules in parallel with no OCPDs in the dc circuits. The inverter manufacturers should be contacted for information in this area. The above equations can be modified by deleting the combined-circuit OCPD and then solved to determine both the requirements for OCPDs and the necessary ampacity of the conductors.

In this case the current flowing through the forward fuse ($n*1.56*I_{sc}$) is set equal to 0 (zero) or removed from the equation. In a system with n strings of modules connected in parallel, if one of the n strings develops a fault, the fault current is now reduced to:

$I_{\text{fault}} = (n-1) * 1.25 * I_{sc}$. For two strings in parallel, $n=2$ and the fault current becomes

$I_{\text{fault}} = 1.25 I_{sc}$.

The *NEC* requires that all PV wiring generally be sized at $1.56 I_{sc}$. The required module series protective fuse is nearly always greater than $1.56 I_{sc}$.

Therefore, in a system with two strings of modules connected in parallel, there are no sources of fault current that exceed the ampacity of the conductors or the requirements for a module protective fuse. No dc string or array fuses would be needed. *NEC* Section 690.9(A) Exception applies.

If there are more than two strings of modules connected in parallel, then the calculations outlined above will have to be made to ensure that $(n-1) * 1.25 * I_{sc}$ is less than the module series protective fuse value. If not, fuses should be used in each string.

APPENDIX K: Flexible, Fine-Stranded Cables: Incompatibilities with Set-Screw Mechanical Terminals and Lugs

Reports have been received over the last several years about field-made connections that have failed when flexible, fine-stranded cables have been used with mechanical terminals or lugs that use a set screw to hold the wire in the terminal. See Figure K-1 for examples of such terminals.

These terminals are used on nearly all circuit breakers (except those with stud-type terminals), fuse holders, disconnects, PV inverters, charge controllers, power distribution blocks, some PV modules, and many other types of electrical equipment.

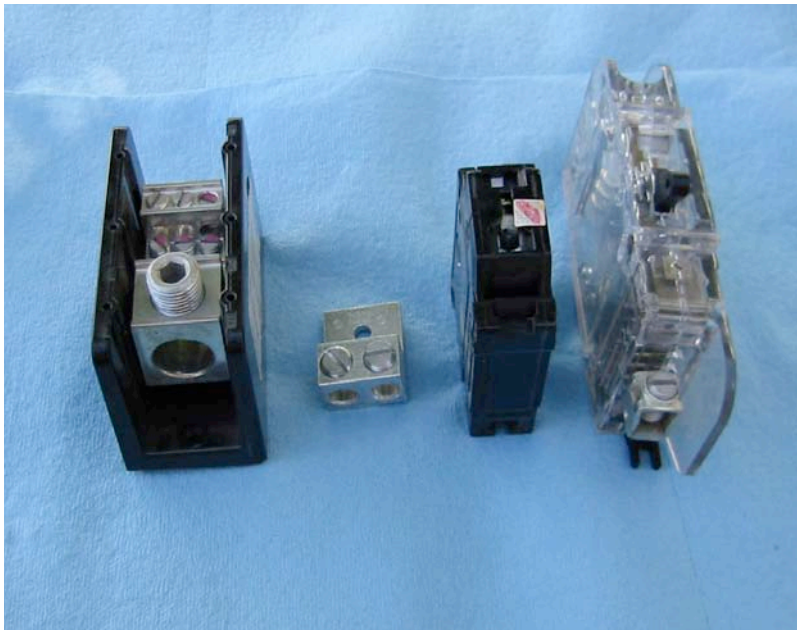

Figure K-1. Examples of Mechanical Terminals

Fine-stranded conductors and cables are considered as those cables having stranding more numerous than Class B stranding. Class B stranding (the most common) will normally have 7 strands of wire per conductor in sizes 18-2 AWG, 19 strands in sizes 1-4/0 AWG, and 37 strands in sizes 250-500 kcmil. Conductors having more strands than these are widely available and are in different classes such as K and M used for portable power cords and welding cables. Commonly used building-wire cables such as USE, THW, RHW, THHN and the like are most commonly available with Class B stranding, but are also *readily available with higher stranding*. Fine-stranded cables are frequently used by PV installers to ease installation and are used in PV systems for battery cables, power conductors to large utility-interactive inverters and elsewhere.

Some modules are supplied with fine-stranded interconnecting cables with attached connectors. While the crimped-on connectors listed with the module are suitable for use with the fine-stranded conductors, an end-of-string conductor with mating connector may also be supplied with the fine-stranded conductor, and the unterminated end of that conductor will not be compatible with mechanical terminals.

According to UL Standard 486 A-B, a terminal/lug/connector must be listed and marked for use with conductors stranded in other than Class B. With no marking or factory literature/instructions to the contrary, the terminal may *only* be used with conductors with the most common Class B stranded conductors. They are not suitable and should not be used with fine-stranded cables. UL engineers have said that few (if any) of the normal screw-type mechanical terminals that the PV industry commonly uses have been listed for use with fine stranded wires. **The terminal must be marked or labeled specifically for use with fine-stranded conductors.**

UL suggests two problems, both of which have been experienced in PV systems. First, the turning screw tends to break the fine wire strands, reducing the amount of copper available to meet the listed ampacity. Second, the initial torque setting does not hold and the fine strands continue to compress after the initial tightening. Even after subsequent retorquing, the connection may still loosen. The loosening connection creates a higher-than-normal resistance connection that heats and may eventually fail. See Figure K-2 for a failed mechanical terminal from a PV system.



Figure K-2. Destroyed Mechanical Terminal From PV System

SOLUTIONS

All electrical equipment listed to UL Standards has:

- Terminals rated for the required current and sized to accept the proper conductors
- Sufficient wire bending space to accommodate the Class B stranded conductors in a manner that meets the wire bending requirements of the *NEC*
- Provisions to accept the appropriate conduit size for these conductors where conduit is required.

It is therefore unnecessary to use the fine-stranded cables except possibly when dealing with conductors 4/0 AWG and larger.

In those cases where a fine-stranded cable must be used, a few manufacturers make a limited number of crimp-on compression lugs in various sizes that are suitable for use with fine-stranded cables. See Figure K-3.



Figure K-3. Typical Compression Lug

Factory-supplied markings and literature indicate which lugs are suitable. An example is the ILSCO FE series of lugs in sizes 2/0 AWG and larger. Burndy makes a YA series of lugs in sizes 14 AWG and up. In both cases the lugs are solid copper. It should be emphasized: *Most crimp-on lugs are not listed for use with fine-stranded wire.* Where the crimp-on compression lugs can be used, they *must* be installed using the tools recommended by the manufacturer and, of course, they must be attached to a stud with a nut and washer.

Burndy and others make pin adapters (a.k.a. pigtail adapters) that can be crimped on fine-stranded cables. These pin adapters provide a protruding pin that can be inserted into a standard screw-type mechanical connector. Again, not all pin adapters/pigtail adapters are listed for use with fine-stranded conductors; some are

intended for use with aluminum wire and others provide only a conversion to a smaller AWG size for B Class conductor or a pin adapter for Class B conductors.

It is suggested that the use of fine-stranded conductors be avoided wherever possible. Where such cables must be used, they should only be terminated with the appropriate connectors/lugs. Previously installed systems should be revisited and the cables replaced where possible or terminated properly.

APPENDIX L: Ungrounded PV Systems

The 2005 *NEC* will permit (not require) the installation of PV systems that do not have one of the dc PV source and PV output conductors grounded. This new go-ahead for ungrounded systems will be in addition to the existing allowance for ungrounded PV systems operating below a systems voltage of 50 volts.

There are a number of additional requirements for these ungrounded PV systems. These additional requirements were established to ensure the safety of the system. Since the United States has over a 100-year tradition of installing, inspecting, and servicing grounded electrical systems, the training and the infrastructure for installing and inspecting ungrounded systems will need to be established.

Most equipment in common use in the United States is designed for use only on grounded electrical systems. Much of the existing PV balance of systems equipment such as power centers and charge controllers, and even some inverters are designed today for use in grounded systems. Radio frequency (RF) filters, required to meet FCC emissions requirements are frequently installed from only the positive conductor to chassis assuming that the negative conductor is grounded. Disconnects in power centers are installed only in the positive conductor and the negative conductors are routed through grounding blocks bonded to the chassis. . The transition to ungrounded PV systems will necessitate new hardware designs and new thinking for surge protection, overcurrent protection, and disconnects.

Electricians and PV installers are trained to install grounded systems. Inspectors are trained and experienced in inspecting grounded, not ungrounded, electrical systems.

Europe, on the other hand, has many years of experience installing not only ungrounded PV systems but also ungrounded ac electrical systems.

Unfortunately, the installation practices and available equipment on each side of the Atlantic have few commonalities. The few items that are common in both arenas, such as the availability of conduit, are used in entirely different ways. The ungrounded European PV systems have as good a safety record as the grounded US PV systems. This addition to the 2005 *NEC* was made to permit the US PV industry to utilize European experience while using US equipment and still meet all safety requirements. The resulting requirements are as follows:

1. Ground-fault detectors will be required on all ungrounded PV arrays for fire protection purposes, not shock protection.
2. Disconnects and overcurrent protection will be required on each circuit conductor unless the system design requires no overcurrent protection in that circuit.
3. The PV source and PV output circuit conductors will be required to be in a raceway or be part of a multi-conductor sheathed cable. This requirement emulates the European use of “double insulated” cable, which is not yet available in the US. When

such “double-insulated” cables become available, are tested and listed to an appropriate UL safety standard, then it is anticipated that they too would meet the intent of this requirement. Listed cables marked “PV Wire” or “Photovoltaic Wire” and “Sunlight Resistant” are being marketed (in late 2006) for this use, but this designation, as an acceptable conductor, will not appear until *the 2008 NEC*.

4. A warning label shall be placed on any termination or location where the ungrounded conductors in raceways may be exposed stating the following:

WARNING: ELECTRIC SHOCK HAZARD. THE DIRECT CURRENT CIRCUIT CONDUCTORS OF THIS PHOTOVOLTAIC POWER SYSTEM ARE UNGROUNDED BUT MAY BE ENERGIZED WITH RESPECT TO GROUND DUE TO LEAKAGE PATHS AND/OR GROUND FAULTS.

5. The inverters or charge controllers used in systems with ungrounded photovoltaic source and output circuits shall be listed for the purpose.

APPENDIX M: SERVICE ENTRANCE CONDUCTOR TAPS FOR UTILITY-INTERACTIVE INVERTER SYSTEMS

Section 690.64 of the *National Electrical Code (NEC)* establishes how and where a utility-interactive PV system may be connected to the utility system. The point of connection may be either on the load side of the service disconnect or the utility (supply) side of the service disconnect. In many cases, the complex requirements for load-side connections established by 690.64(B)(2) make such a connection impractical and dictate that the utility-interactive inverter be connected on the supply side of the service disconnect. Here are some, but not all, of the major code sections that address the requirements for such a connection.

Section 690.64(A) allows a supply (utility) side connection as permitted in 230.82(6).

Section 230.82(6) lists solar photovoltaic equipment as permitted to be connected to the supply side of the service disconnect.

It is evident that the connection of a utility-interactive inverter to the supply side of a service disconnect is essentially connecting a second service entrance disconnect to the existing service and many, if not all, of the rules for service entrance equipment must be followed.

Section 240.21(D) allows the service conductors to be tapped and refers to 230.91.

Section 230.91 requires that the service overcurrent device be co-located with the service disconnect. A circuit breaker or a fused disconnect would meet these requirements. A utility-accessible, visible break, lockable (open) fused disconnect (aka safety switch) may also meet utility requirements for an external PV ac disconnect.

Section 230.71 specifies that the service disconnecting means for each set of service entrance conductors shall be a combination of no more than six switches and sets of circuit breakers mounted in a single enclosure or in a group of enclosures. The addition of the photovoltaic equipment disconnect would be one of the six.

Section 230.70(A) establishes the location requirements for the service disconnect. Section 705.10 requires that a directory be placed showing the location of all power sources for a building. Locating the PV service disconnect adjacent to or near the existing service disconnect may facilitate the installation, inspection, and operation of the system.

Section 230.79(D) requires that the disconnect have a *minimum* rating of 60 amps. This would apply to a service-entrance rated circuit breaker or fused disconnect.

Section 230.42 requires that the service entrance conductors be sized at 125% of the continuous loads (all currents in a PV system are worst-case continuous). The actual rating should be based on 125% of the rated output current for the utility-interactive PV inverter as required by 690.8.

The disconnect must have a 60-amp minimum rating. Larger conductors may be required after temperature and conduit fill factors have been applied.

For a small PV system, say a 2500-watt, 240-Volt inverter requiring a 15-amp circuit and overcurrent protection, these requirements would appear to require a minimum 60-amp rated disconnect, but 15-amp fuses could be used; fuse adapters would be required. While 15-amp conductors could be used between the inverter and the 15-amp fuses in the disconnect, Section 230.42(B) requires that the conductors between the service tap and the disconnect be rated not less than the rating of the disconnect; in this case 60 amps.

Dealing with the 60-amp disconnect, 15-amp over current requirements using circuit breakers is not as straightforward. A circuit breaker rated at 60-amps could serve as a disconnect and it could be connected in series with a 15-amp circuit breaker to meet the inverter overcurrent device requirements. In this case the requirements of 690.64(B)(2) should be applied for the series connection.

Section 110.9 requires that the interrupt capability of the equipment be equal to the available fault current. The interrupt rating of the new disconnect/overcurrent device should at least equal the interrupt rating of the existing service equipment. The utility service should be investigated to ensure that the available fault currents have not been increased above the rating of the existing equipment. Fused disconnects with RK-5 fuses are available with interrupt ratings up to 200,000 amps.

Section 230.43 allows a number of different service entrance wiring systems. However, considering that the tap conductors are unprotected from faults, it is suggested that the conductors be as short as possible with the new PV service/disconnect mounted adjacent to the tap point. Conductors installed in rigid metal conduit would provide the highest level of fault protection.

All equipment must be properly grounded per Article 250 requirements. See 250.24(B) for bonding requirements. Neutral-to-ground bonding is generally required at each service disconnect.

The actual location of the tap will depend on the configuration and location of the existing service entrance equipment. The following connection locations have been used on various systems throughout the country. On the smaller residential and commercial systems, there is sometimes room in the main load center to tap the service conductors just before they are connected to the existing service disconnect. In other installations, the meter socket has lugs that are listed for two conductors per lug. Combined meter/service disconnects/load centers frequently have significant amounts of interior space where the tap can be made between the meter socket and the service disconnect. Of course, adding a new pull box between the meter socket and the service disconnect is always an option. In the larger commercial installations, the main service entrance equipment will frequently have bus bars that have provisions for tap conductors. In the larger commercial installations, the main service equipment may have bus bars that are marked for and provided with provisions for tap conductors.

In all cases, safe working practices dictate that the utility service be de-energized before any tap connections are made.

Additional service entrance disconnect requirements in Article 230 and other articles of the *NEC* will apply to this connection.

INDEX

A

acid, 3, 42, 53, 54, 55
 Aluminum, 9
 amp ratings, 36
 ampacity, 2, 7, 10, 33, 34, 35, 36, 38, 39, 42, 56, 65, 66, 68,
A-2, B-3, B-4, E-1, E-2, E-3, E-4, E-6, E-7, E-8, E-9, E-10, E-11, E-12, E-15, E-16, E-18, E-19, E-20, E-23, E-26
 array, 11, 19, 20, 21, 23, 32, 37, 38, 41, 42, 48, 49, 50, 64,
70, C-6, D-1, D-2, D-3, D-4, E-4, E-6, E-7, E-9, E-11, E-12, E-14, E-15, E-16, E-18, E-20, E-21, E-23, E-24, E-25, E-26

B

batteries, 2, 3, 15, 36, 42, 44, 46, 52, 53, 54, 55, *E-9, E-10, E-12, E-14, E-16, E-19*
 Battery, 48, 50, 52, 53, 54, 55
 battery voltage, 50, 54, F-1, F-2, I-1

C

charge controller, 23, 26, 49, 50, 57, 60, *E-9, E-10, E-13, E-17*
 circuit breaker, 27, 45, 46, 48, 50, 63, 65, 69, D-4, E-9, E-12, E-16, E-17, E-19, E-20, E-21, E-24, E-26
 conductor, 10, 14, 15, 17, 19, 20, 21, 22, 23, 24, 25, 26, 27, 28, 32, 34, 35, 36, 38, 44, 46, 52, 53, 54, 55, 56, 57, 61, 62, 63, 64, 65, 66, 68, A-1, A-2, B-4, D-2, D-3, D-4, E-1, E-2, E-3, E-8, E-12, E-13, E-14, E-16, E-17, E-20, E-23, E-24, E-26
 conductors, 2, 7, 9, 10, 11, 13, 14, 15, 16, 19, 21, 22, 23, 24, 25, 26, 27, 28, 29, 31, 32, 33, 34, 35, 36, 37, 38, 39, 42, 45, 46, 47, 51, 52, 56, 60, 62, 63, 64, 65, A-1, B-2, B-3, B-4, C-3, C-4, C-6, E-2, E-3, E-4, E-6, E-7, E-8, E-10, E-12, E-13, E-15, E-16, E-18, E-19, E-20, E-23, E-24, E-26, E-27, F-2, G-3, H-1, H-3, J-3, K-1, K-2, K-3, K-4, L-1, L-2, M-1, M-2
 conduit, 8, 10, 11, 14, 15, 34, 52, 53, 62, B-4, C-6, D-2, D-4, E-2, E-3, E-8, E-9, E-10, E-12, E-14, E-16, E-19, E-21, E-26
 copper conductor, G-2, G-3
 Copper conductors, 9, G-1
 current rating, 56

D

dc rating, 41
 derating, 11, B-4, E-1, E-9, E-11, E-12, E-15, E-18, E-19, E-23, E-25, E-26

device rating, 7, 42, 68, E-2
 disconnect, i, 15, 16, 18, 19, 20, 21, 36, 44, 45, 46, 47, 48, 50, 51, 52, 53, 56, 59, 60, 62, 64, 68, C-3, C-5, D-2, D-4, E-3, E-6, E-9, E-10, E-12, E-14, E-16, E-19, E-20, E-23, E-24, E-26, E-27, H-2, H-3, M-1, M-2, M-3
 disconnect switch, 21, 44, 50, 60, 68, E-3, E-10, E-16
 Disconnects, iv, v, vii, 39, 46, 47, 49, 50, 51, 57, L-1

Electric shock, 52
 electric spark, 53
 equipment-grounding conductor, 19, 27, 28, 32, 62, E-20, G-2

F

fuses, 2, 39, 40, 41, 42, 43, 44, 49, 56, 59, A-2, A-3, B-2, C-3, C-6, D-2, D-4, E-10, E-12, E-15, E-26

G

generators, 31, 36, 55, 56
 GFPD, vii, 19, 25, 30, 31, H-1, H-2, H-3, H-4
 GFPDs, 30, H-1, H-2, H-3
 Grid-connected, C-1
 ground fault, 63, D-3, H-1
 ground faults, 25, 54, D-2, H-1, H-2, H-3
 grounded, 17, 19, 21, 22, 25, 26, 27, 28, 32, 46, 51, 57, 63, C-1, C-6, D-1, E-4, E-6, E-9, E-12, E-20, E-23, E-24
 Ground-Fault, iii, iv, vii, viii, 19, 20, 24, 25, 29, 30, 31, 46, 48, 54, 63, 67, C-6, D-3, E-17, H-1, H-2, H-3, H-4, J-1
 ground-fault currents, C-6
 ground-fault detection, 19
 Ground-fault detectors, L-1
 ground-fault device, D-3
 ground-fault interrupter, 25
 Grounding, iii, iv, v, vii, viii, ix, 2, 16, 19, 21, 22, 23, 24, 25, 26, 27, 28, 29, 31, 32, 33, 36, 46, 52, 55, 56, 57, 61, 62, 63, A-1, C-6, D-3, E-4, E-6, E-8, E-10, E-12, E-13, E-16, E-20, E-24, E-26, G-1, G-4

I

Interrupting Rating, 42, 43
 inverter, 22, 24, 25, 26, 27, 28, 31, 35, 36, 40, 44, 45, 48, 51, 56, 59, 63, 64, 66, D-2, D-4, E-1, E-14, E-16, E-17, E-19, E-20, E-21, E-23, E-24, E-26

J

junction box, 9, 13, 14, 55, D-3, E-11, E-12, E-14, E-15

L

Listed connectors, 32
 load center, 28, 29, 31, 32, 40, 45, 47, 59, 60, 64, 65, 66, C-1, C-2, C-3, C-4, C-5, E-13, E-19, E-21, E-23, E-24, E-26, E-28, M-2
 locking connectors, 62

M

module, 2, 7, 8, 10, 11, 14, 15, 16, 17, 19, 20, 21, 27, 32, 34, 35, 37, 59, B-2, B-3, B-4, D-1, D-3, D-4, E-1, E-3, E-9, E-11, E-15, E-20, E-24, E-25
 Module connectors, 16
 module frames, 19, G-1

O

output current, 20, 35, E-23, E-26, E-27, F-1, M-2
 overcurrent device, 18, 27, 35, 36, 37, 38, 42, 43, 44, 45, 48, 56, 68, B-3, C-3, C-6, E-1, E-2, E-3, E-7, E-8, E-10, E-18, E-20, F-2, H-2, I-1, I-2, J-1, M-1, M-2
 overcurrent protection, i, 2, 6, 20, 36, 37, 38, 47, 50, A-2, A-3, E-1, E-10, E-15, E-16, E-19, E-20, E-24, L-1, M-2

P

pressure connectors, 17

R

rating of overcurrent devices, 35
 RMS value, F-1, F-2
 RMS values, F-2

S

service entrance, 21, 45, 47, 59, 64, 65, C-3, E-21, E-24, E-26, M-1, M-2, M-3
 shock, 3, 20, 21, 54, C-4, C-5, G-1, H-1, L-1
 single-pole disconnect, E-23
 split-bolt connectors, 16
 stand-alone inverter, 24, 28, F-1

T

temperature rating, 7, 10, B-4, E-1, E-2

U

UL-Listed, 3, 13, 39, 40, 43, 46, 48, 59, A-2, D-4, E-1
 Underwriters Laboratories, 2, 4, 52, B-1, C-4, D-2, G-1, H-2, J-1
 ungrounded, 19, 20, 21, 27, 30, 31, 32, 36, 37, 44, 45, 46, 47, 51, 64, 65, C-1, C-5, E-3, H-1, H-2, H-4, L-1, L-2

V

voltage rating, 37, C-3, E-5, E-8, E-13, E-16, E-20, E-24, E-26

W

wire connectors, 17
 wiring, ii, 3, 4, 8, 9, 10, 12, 14, 15, 16, 19, 21, 35, 37, 38, 61, 63, 65, B-1, C-3, D-2, E-6, E-10, E-11, E-12, E-15, E-16, E-21, E-24, E-25, E-26

DISTRIBUTION LIST