

Visualization of Small Wind Turbine Blades

- 1: Find a pair of kitchen or dressmaker's scissors - such as shown below. Notice that the handles are at about an angle of 20-25 degrees below the horizontal angle of the cutting blades - down to the right.
- 2: Hold the scissors up in an edgewise position - at arm's length in front of your face as shown. We are looking directly and flat-on "down" at the scissors and at what we will now call the - **Top or Upper Side**.
Note that the top blade-edge is horizontal and is on your left. This upper side edge of the scissor blades - we will now call the - **Leading Edge A** - this is the blade edge that first meets the air - when the blade [or rotor] rotates in a normal and clockwise direction. The bottom or lower scissor blade is now called the **Trailing Edge A**. The trailing edge is the rear edge where the air-stream leaves the blade. We will also call the lower handle of the scissors - **Leading Edge B** and the upper handle **Trailing Edge B**.

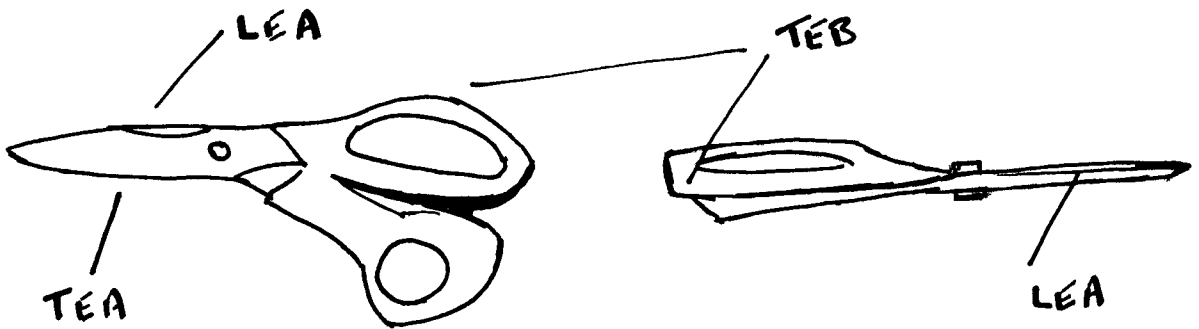

- 3: Now rotate the blades away from you. You will now see that the scissor blades are now flat at a horizontal angle - while the handles are at about an angle of 15-20 degrees up to the right.
- 4: Now move your body round to the other side of the flat scissors - so that one is now looking directly at the scissors from what was formerly "the rear or far side". One will of course notice that the handles are now on the left - with the **Trailing Edge B** - directly facing you on the left and the **Leading Edge A** - directly facing you on the right.
[And of course **Leading Edge B** - is on the left-hand rear side and **Trailing Edge A** likewise on the right-hand far side]
- 5: It is important to also visualize - that the before-mentioned and flat **Upper Side** - is the side of the blades or **Wind Turbine Rotor** - that first meets the wind "head-on" and is normally more-or-less formed in a flat angled shape - going from the **Leading Edge** to the **Trailing Edge**. The opposite or underneath side of this "flat-angled shape is formed as an aerodynamic curve - like the top of an aeroplane wing.
- 6: In the scissor situation example mentioned above under 4: - The thickest aerodynamic section of blade **B** - will therefore be on the left-hand underneath far side - while the thickest aerodynamic section of blade **A** - will be on the right-hand near side.

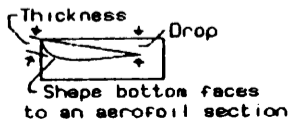
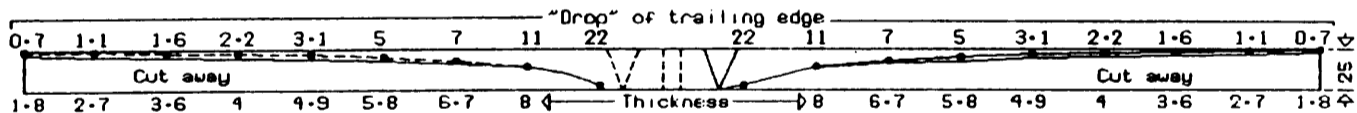
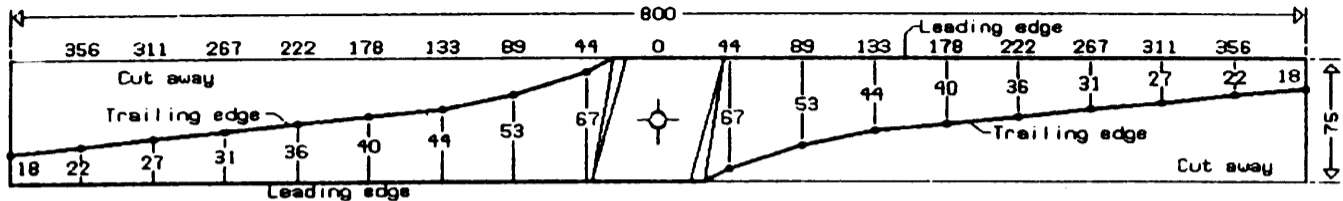

Material: Quarter sawn Oregon Pine or Pitch Pine.

Finish: 4-5 coats of Polyurethane Paint.

Tools: Callipers, Saw, Mallet, Chisel, Drawknife, Spokeshave, Sandpaper.

Fit the propeller so that the curved side of the blades face downwind.

All dimensions are in millimetres

Corrections to rotor-drawing:

Please note that the above drawing is “backwards” - and can be easily misunderstood by an inexperienced experimenter. A more correct view is shown below.

It should be noted that the finished rotor should face the wind and thereafter turn in a clockwise direction as viewed by an observer facing the rotor with the wind blowing on the observer’s back.

1: Front or top “flat”-side - facing the wind direction.

2: Rear or lee curved-side on the opposite side from the wind direction

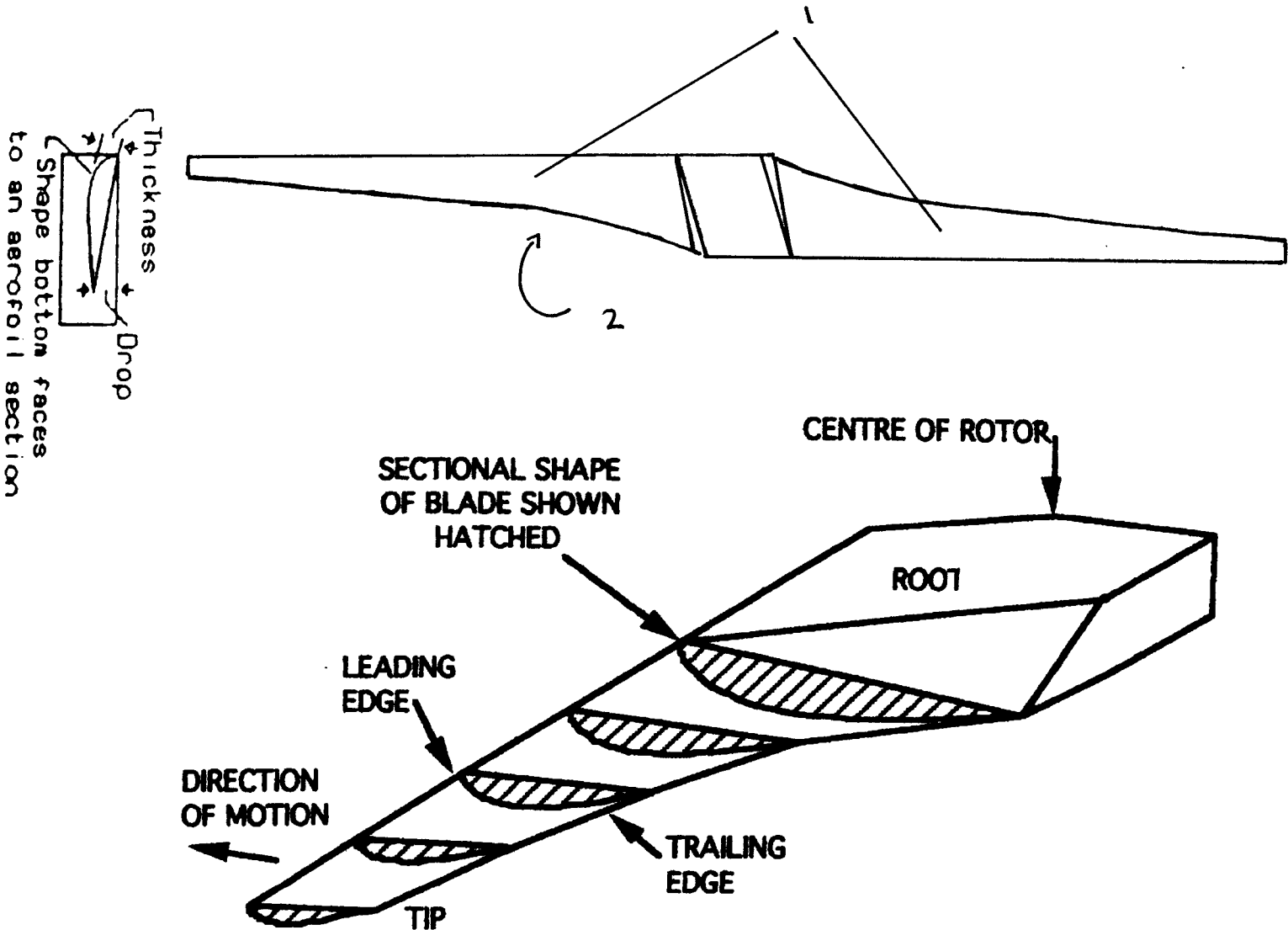

The twisted shape of the blade

The windward face of the blade is flat, like the underside of an aircraft wing. The blade angle needs to be coarser at the root than it is at the tip. Figure shows a series of sectional views of the blade, to indicate how they change in size and angle between the tip and the root of the blade. The angle of the blade changes because the ratio of blade-speed to windspeed becomes less as we approach the centre. This affects the angle of the actual air velocity striking the blade at each station.

A-A

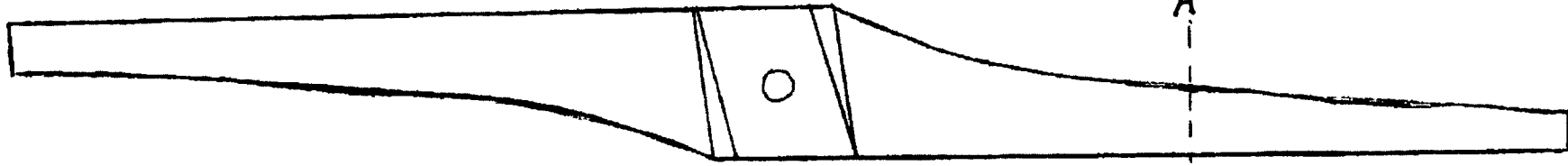

A



B

A

A



B

THE PROPELLER

The whole performance of a wind generator depends upon the propeller running at the correct rpm over the required wind speed range with sufficient power to drive the generator. Small high speed wind generators require a propeller with a tip speed ratio of approximately 8:1 (i.e. the tip of the propeller travels 8 times faster than the wind speed). This type of propeller has thin parallel sided blades with a fixed pitch of 6 degrees.

The traditional (and still best) material for small propellers is wood.

This should be of the highest quality, straight grained and free from any warping, knots or cracks.

Recommended woods include :- Sitka spruce
Beech
Mahogany

Construction (see Fig. 8)

1. Cut a piece of wood accurately to 65" x 3½" x 1".
2. Using a fine tooth saw, or bandsaw, or plane, accurately cut a 6 degree angle for 28" from the tip of each blade. Blend a smooth bend at the end of the cut.
3. Cut the front of the aerofoil of each blade (section 'A') to give a leading edge ¼" thick.
4. Cut the back of the aerofoil of each blade (section 'B') to give a trailing edge 1/8" thick.
5. Drill a ½" centre hole in the propeller and two 3/8" mounting holes at 3" radius.
6. Sand the propeller smooth. Round off leading & trailing edges.
7. Weld a piece of mild steel 8" x 2" x ¼" onto the alternator pulley after first drilling two 3/8" holes and a centre hole large enough to tighten the pulley nut through.
8. Paint the propeller with either 3 coats of polyurethane varnish or two coats of epoxy paint.
9. Mount the propeller on the pulley assembly and then on the alternator shaft for balancing. Add balance washers as required. Secure either on one mounting bolt or with wood screws at the root of the blade

FIG. 8 - PROPELLER CONSTRUCTION

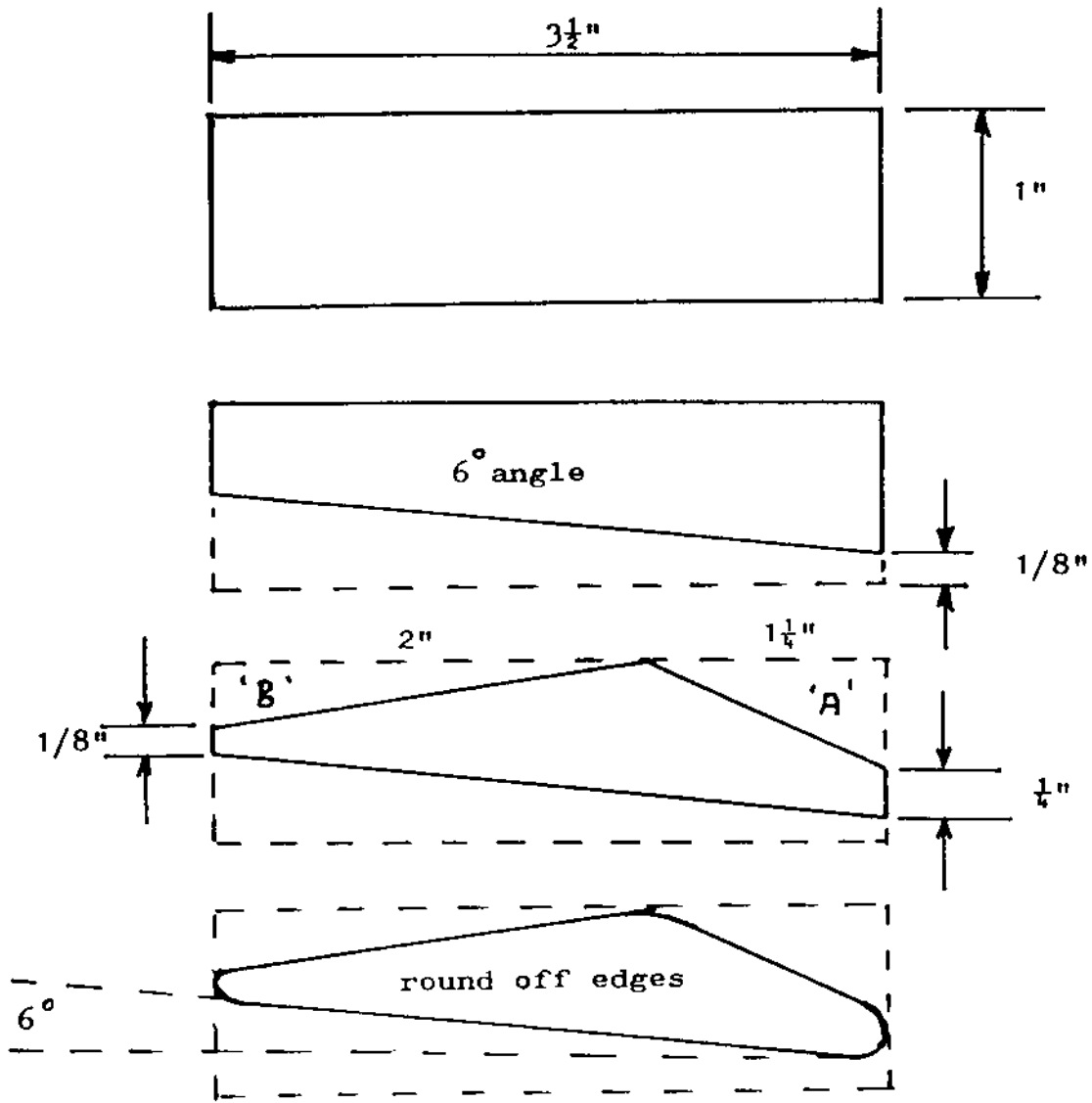

weld $8" \times 2" \times \frac{1}{4}"$ strip onto pulley

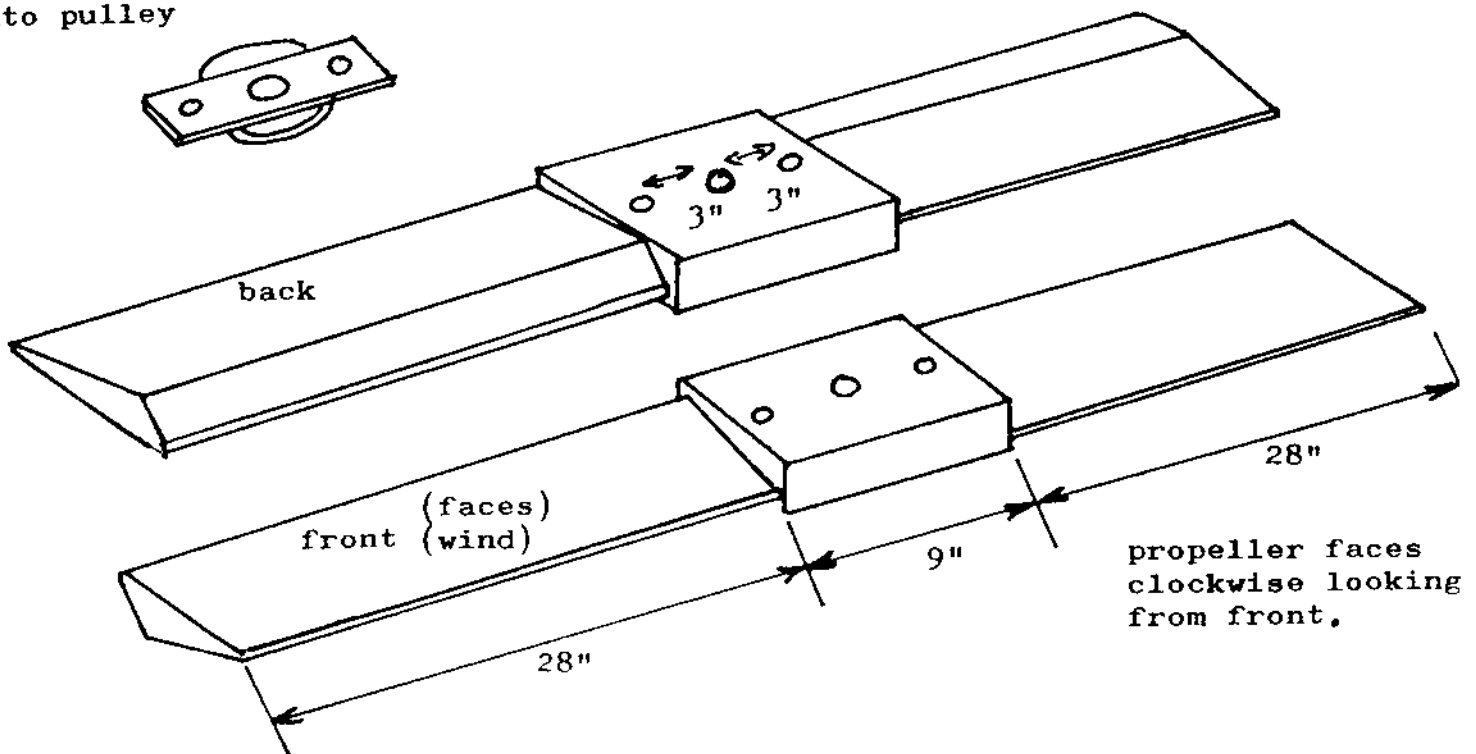

BLADE CARVING

Friends:

It has been our objective to conduct research into "construction and ease of visualisation during the process of rotor-blade-construction". It is our impression that many "blade-designs" are difficult to visualize [if not to say very difficult, confusing and indeed perhaps too complicated] - and it is therefore advisable to "take your time and have a simple model for reference".

Please take time to carefully read-through the following notes several times. It is indeed a complicated process - but only once. Please consult the relevant above mentioned drawing.

In this respect it should be noted that Hugh Piggott and other friends have recently done much to improve the visualization process prior to marking-out of the individual blades on their latest three-bladed models. See links and downloads etc. - www.scoraigwind.co.uk - & - www.otherpower.com ; www.forcefield.com

It has also been our objective to experiment with glued-strips. Finally it is our intention to further experiment with longer - straight-sided blades as shown on the specially-available CD-4 in several different files. However the necessity for our large, heavy and now lengthwise-sawn beech logs to be more fully dry has meant a postponement of this task.

01: We consider and we have also observed on several occasions - that in constructing blades from drawings - there is always a great possibility of MISTAKING the correct direction of rotation and therefore - ?????? - which blade is carved to rotate in which direction. We have decided that to avoid this possibility it is advisable to first construct the ultra-simple blade - as shown above on **Page 6** in this present file. The whole and complete file can be found on CD-1 in the file "Low-cost Windmills"

02: This simple 65" inches x 3½" inches x 1" inches - two bladed rotor has only three straight angles on each blade. However as shown in the above drawing [and to be very correct] - it does first need a calculation of 3½" x tangent 6 degrees and then a reversion back into fractions of inches => about 3/8" inch and add then a 1/4" inch to find the correct angle height on the plank trailing edge.

03: This model with a 65" diameter [just over 165 cms] rotor and with plain straight-sided shape with a plank width of 3½" [just under 90 mm] and start thickness of 1" [25.4 mm] - is highly suited for not only experimenting but as a visualisation model. As the main working measurements for this blade are hereafter given in **inches** - the following figures in **millimeters** are given solely as a rough reminder and as assistance. However for this project it is highly recommended to use inches if possible:

1"	=	25.4 mm
1/8"	=	3.18 mm
1/4"	=	6.35 mm
½"	=	12.7 mm
5/8"	=	15.88 mm
¾"	=	19.05 mm

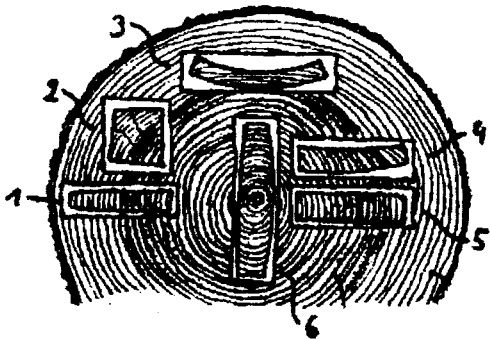

Best

OK

Luvseite



Leeseite

Profil Brett

BRAUCHBAR



SCHLIMM



BRAUCHBAR



Verzug von etwas feuchtem Holz beim Austrocknen:
Kernseite wölbt sich, also: Lee!

Verzug von extrem trockenem Holz: Kernseite Luv!

"Blockverleimte" Bohle:



Leisten immer „Rücken an Rücken“
gedreht, also Maserung entgegen-
gesetzt = Verzug hebt sich auf!

Bei Selbstbau möglich:



Leisten passend zusägen, außen Hart-
holz: stabiler, spart Holz und Arbeit!

04: Low-cost planks - 190 cms x 2.5 cms x 10 cms - were purchased and cut into thin strips of 190 cms x 2.5 cms x 3 cms - using an old small-size Black & Decker hand-held circular-saw. These strips were then glued with a good BOSTIK waterproof and "flexible" construction wood-glue. We had previously decided that we would not use more expensive epoxy-glue as these blade rotors were solely for prototype experimental carving.

05: The strips were glued and clamped with many large screw-clamps and laid-out on the workshop floor on a sheet of plastic.

06: The BOSTIK glue has a drying time of 30 minutes - however with our cold workshop winter temperature of about 5-7 degrees and possibly also because of this both cold and damp - the glue was still not quite dry the next morning - however the actual "plank" itself looked good and strong. Because of the different internal "stresses" in the individual strips [and possibly the cold temperature] there were now considerable height differences between the individual strips - both on the top and the bottom - in spite of being very tightly clamped with heavy-duty wooden-formwork concrete construction screw-clamps. This suggests that future glued work must be very heavily top-loaded to prevent possible "spring" or twisting "stress-effects".

07: Because the glue had not completely hardened - it was a difficult task to first scrap off as much as possible of the excess glue in between the different "strip-height differences" - before we were ready to use either the Stanley plane or the Bosch electric planer. This was to avoid clog-up or damage to the tool cutting edges or risking a blockage in the flexible-plastic air-suction hose from the machine-plane to the industrial-type workshop vacuum-cleaner.

NB: Non-mechanical hand tools are needed - such as a Stanley hand-plane, a drawknife a spokeshave and a Stanley SURFORM "rasp-shaper" have been used with success. In addition to a Bosch machine plane, a Holz-Her belt sander, a Black and Decker orbital sander, a Scintilla-Bosch orbital jig-saw and a small Black and Decker circular saw.

08: It is recommended to make the strip-height 30 mm - as the "finished-plank" - prior to the carving has to be at least 1" inch [25.4 mm] thick - thereby allowing adequate and sufficient reserve-excess wood to remove.

09: An minor but very unfortunate accident with an incorrect small-cut with the circular saw on one edge of the wooden plank required a repair with the inserting, gluing and clamping of a small repair-strip of wood - 5 mm x 30 mm x 200 mm. For fine edge-trimming or lengthwise cutting it is advisable to preferably either use a proper table-saw or else with careful use of a good hand-held orbital jig-saw - such as a Scintilla-Bosch. Even though the cuts are perhaps not as straight as with a circular saw, any irregularities can be smoothed out either with the spokeshave or a sander. AND one is always in complete "view" of the actual cutting operation.

10: The 9" [app. 229 mm] center section was measured from the ends and the "center position" found and marked. This center section was marked-up and squared and the two lines each at 4½" [app. 114 mm] from the exact center were also squared and drawn across the flat surface. A further middle line was drawn through the center-point lengthwise through this "box". There are now four rectangles in this upper surface 9" x 3½" [app. 229 mm x 89 mm] box. These measurements are repeated on the reverse side and each of the three upper lines joined with the three reverse-side lines around the 1" [25.4 mm] plank-edges.

11: On each flat side in this "center box" there are now 4 small rectangles each measuring - 4½" long x 13/4" [app. 114 mm x 44 mm] wide

NB: This measurement reads - **four & a half inches long and one & three quarters of an inch wide.**

On the upper left-side rectangle draw an arrow pointing-up and write "WIND". Now in the lower right-hand side draw another arrow pointing-down and again write "WIND".

12: Along the drawn center line from left to right now write - "FRONT" or "TOP".

NB: The Blade rotates in a clockwise direction and this is the side that the wind will first meet - as seen by a person standing in front facing the blade - with his own back to the wind.

13: Turn the plank lengthwise over and write along the rear center line "BACK"

NB: The top and bottom surface-lettering of the words "FRONT" and "BACK" must be written in the same plane and of course on opposite sides of the plank.

14: Position or turn the plank round "BACK" [rear-side] - so that the lettering "BACK" is now upside-down. Measure 1¼" [one and one quarter of an inch - app. 32 mm] UP from the bottom of the lower left edge of the left-hand side lower rectangle and then project and draw the line - out to the left-hand edge of the plank. This is now written on the surface with a pencil as line "A"

This line will mark the highest point of the left-side rear or "BACK" aerofoil-shape.

15: Repeat the process by measuring 1¼" [app. 32 mm] DOWN and out to the right from the upper right edge of the top right-hand rectangle of the same "BACK" -side and written in as line "B".

These two lines "A" and "B" will mark the highest points of the aerofoil shape

16: Now turn the plank over and towards you 270 degrees - so it is now on edge on the work-bench. The side and lettering marked "FRONT" is now facing you [with the lettering "FRONT" the right way up]. Starting from the "squared box lines" on the upper top left-hand side marked "WIND" - measure 1/8" [app. 3 mm] DOWN - out and away from you and across the 1" [25.4 mm] edge. Make a mark "C" and thereafter further measure and mark again 1/4" [app. 6 mm] -"D". Thereafter project these two parallel lines [1/4" apart - app. 6 mm] out to the left edge or tip.

17: Rotate the plank on the work-bench 180 degrees away from you - on edge [BACK is now facing you - and again upside down]. Repeat the same procedure. Across from the "FRONT" original lower right-hand rectangle edge [and in this present position - now towards you] mark "E" and "F". These two parallel lines must be projected out to the right-hand edge of the plank. These 4 lines "C" "D" and "E" "F" - are the "leading edges" of the blades.

18: Now measure 5/8" [app. 16 mm] towards you from the edge of the FRONT lower left-hand rectangle "G". Thereafter measure a further 1/4" [app. 6 mm] - "H". Project these two parallel lines out to the left-hand tip.

19: Rotate the plank 180 degrees away from you - so that FRONT is now facing you. Repeat the same process and measure 5/8" [app. 16 mm] across from the edge of the right-hand upper rectangle. Project these lines out to the right-hand tip - "I" and "J". These 4 lines "G" "H" and "I" "J" are the "trailing edges" of the blades.

20: Go out to the squared tip-ends and join-up the different projected lines. It will now be seen that they form an aerofoil shape. Looking at the plank with the FRONT facing you - with the lettering the right-side up - it will be seen that - the "left" flat side [facing the wind] slopes DOWN from the FRONT upper left-hand side rectangle. And the "right" flat side [- of course also facing the wind] slopes UP from the FRONT upper right-hand side rectangle.

21: Now go through all these measurements a second and third time to check and control. Be especially careful if you have used **mm** instead of **inches**.

22: Place the plank on top of another plank to avoid excess vibration especially at the tip end while working with tools. Use a screw-clamp placed with the center "BACK" section uppermost and fasten them both to the work-bench.

23: Using a draw-knife and plane carefully remove away as much of the wood as possible from the visible 1 1/4" [app. 32 mm] pencil-lines "A" and "B" down to the pencil line on the edges "D" and "F".

NB: PLEASE BE VERY CAREFUL - AND CHECK THAT YOU DO NOT REMOVE TOO MUCH WOOD - OR MISTAKE THE DIFFERENT PARALLEL LINES !!!.

24: Then repeat the process from other side of the still visible pencil lines "A" and "B" - down to the lines "H" and "J".

25: Use a fine-set spokeshave during the later stages of this work. For cutting along the edges and sides of the large center rectangle, we used a fine-toothed saw - however even this saw was perhaps too big and clumsy for this purpose. A hacksaw, or hacksaw blade, knife and rasp are preferable and recommended.

26: Turn the plank over so that the "FRONT" side is now on top and fasten as previously described. Using the draw-knife, plane and spokeshave - carefully remove the wood across the whole width of each blade from "C" across to "G" on the left-hand side and from "E" across to "I" on the right-hand side.

NB: DURING THESE STAGES - DO NOT REMOVE ALL WOOD RIGHT DOWN TO THE DRAWN LINES.

27: As all main sections on this blade design are flat and straight - it is a very easy task - with careful use of a good belt-sander and orbital sander to remove most of the final last remaining uneven areas down to the pencil lines.

28: The blade sections will need a final sanding and finish with a wooden block and fine sand paper and also rounding and smoothing of the leading and trailing edges [between lines "C" "D" and "E" "F" and likewise between lines "G" "H" and "I" "J" - in addition to a smoothing-over of lines "A" and "B"].

29: Finally the necessary shaft measurements, drilling, fixing and balancing etc will of course still be necessary before the blade is finally finished.

However as mentioned above - the purpose of the whole operation was the following:

A: Visualization of shape - etc.

B: Experimentation with glued strip wood for blades.

Results from this process have been highly favourable - without however - actual wind testing for performance or reliability etc.

Although we have noticed that even though many serious problems with imperfections in the wood are avoided by the use of glued wooden strips, two areas have been encountered where the over-energetic use of the draw-knife near knots and other potential weak areas and faults - rather than using the belt-sander - has resulted in a couple of small imperfections. In future only "near-perfect and good" wooden strips should be used in any gluing process.

However in reality this necessary more careful selection of strips presents no real difficulty and the actual encountering of this problem can perhaps only have resulted from lack of necessary concentration or quality control during the strip-assembly prior to gluing process.

The working time taken for this "second-stage" and second day final blade-carving process - and after the "plank" has been either previously cut, glued, assembled, clamped and prepared or otherwise specially identified, selected and purchased from a good specialized lumber-yard: - The whole process has taken about 1 hour for the measuring and "marking-up" [including the very essential measurement checking and then again re-checking] and about 1½ hours for the actual wood carving process itself.

With a more systemized approach - and even at this present stage - it should be possible to produce a finished "simplified-design" two-meter two-bladed rotor in about 3½ - 4 hours or at a rate of at least about 2 units per day for the whole and complete process.

Greetings - John, Jafar & friends - with thanks to Claus, Hugh, Christian Kutzt & Jemmett - 2002-2003. - furze@post.tele.dk